

LOC	DIST	REVISIONS			
P	LTR	DESCRIPTION	DATE	DWN	APVD
AF	50	P	REV PER 0G3A-0144-03	11MAR03	JR PD

- CONTINUOUS STRIP ON REELS.
- MATING TAB THK IS 0.81 ± 0.025 $[\.032 \pm .001]$.
- WIRE SIZE IS [20-16] AWG.
- INSULATION RANGE IS 2.29-3.30 $[\.090-.130]$ DIA.

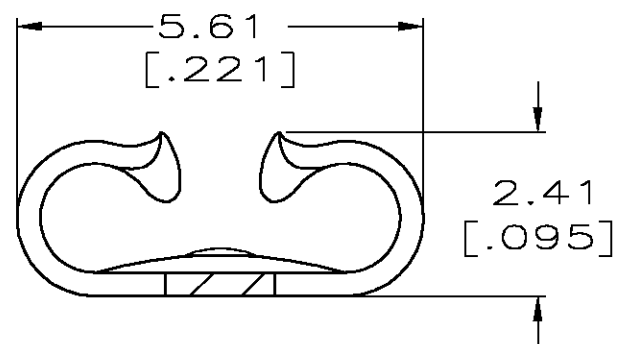

VIEW A-A
SCALE 10:1

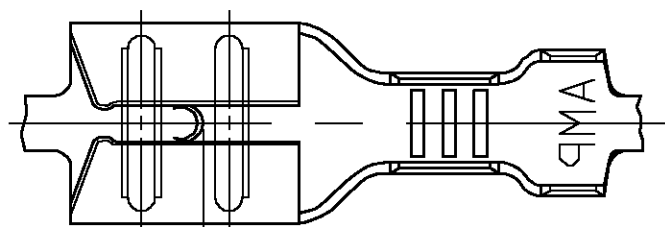
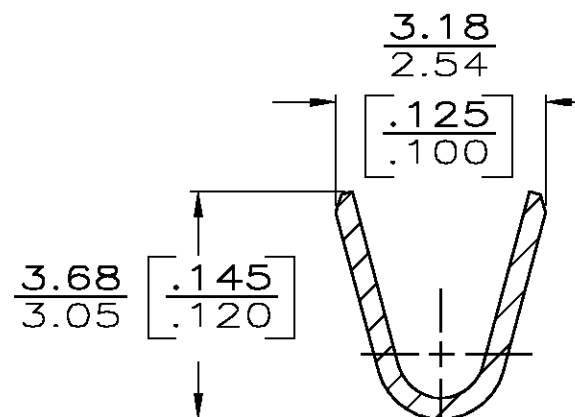
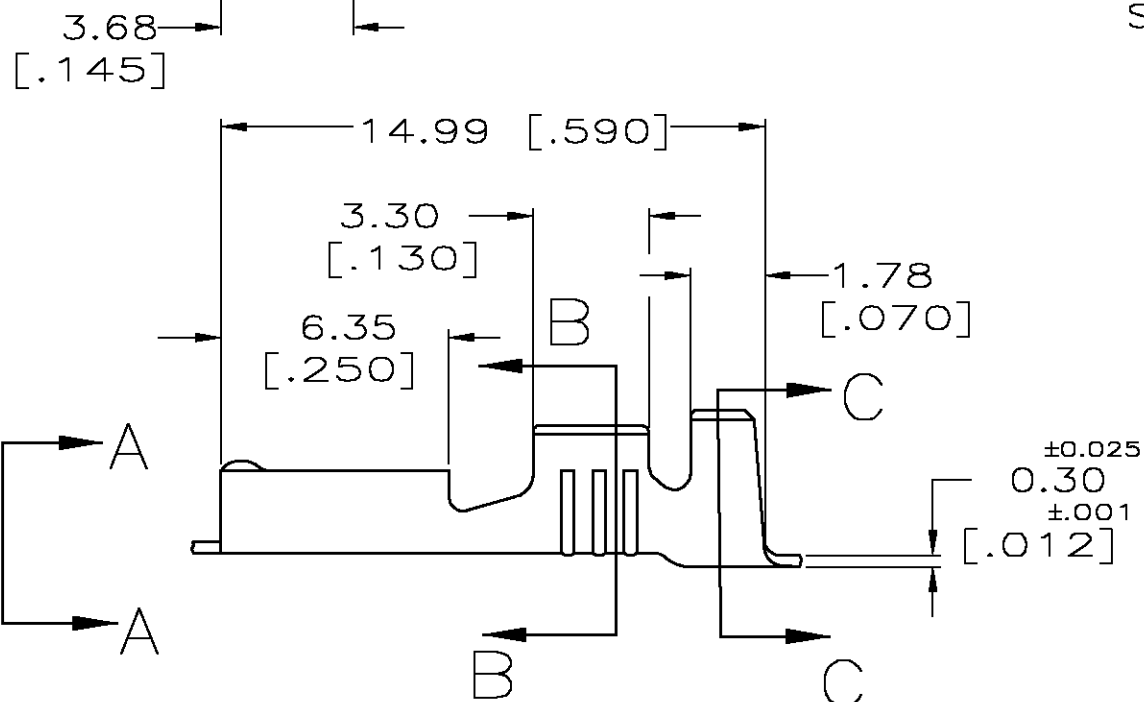

SECTION B-B
SCALE 10:1

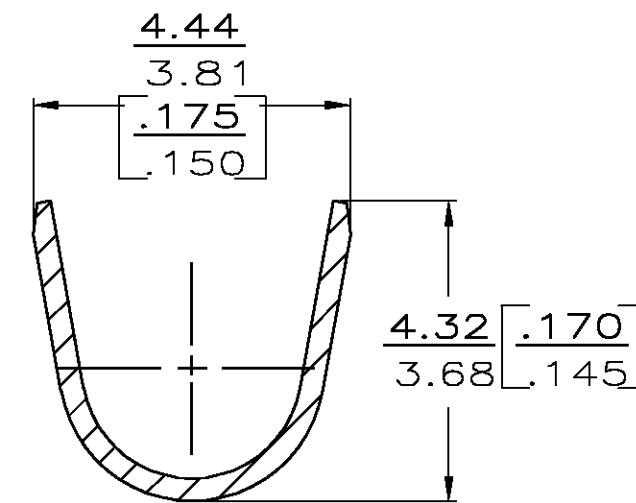

SECTION C-C
SCALE 10:1

60196-3	0.002032 $[\.000080]$ MIN TIN	60196-2
-	-	60196-1
LOOSE PIECE	FINISH	PART NO

THIS DRAWING IS A CONTROLLED DOCUMENT.		DWN	JR RUTH	8/27/91	Tyco Electronics Corporation Harrisburg, PA 17105
DIMENSIONS: INCHES		CHK	P FORTNEY	8/27/91	
		APVD	C MEYERS	8/27/91	
TOLERANCES UNLESS OTHERWISE SPECIFIED: 0 PLC ± - 1 PLC ± - 2 PLC ± 0.38 $[\.015]$ 3 PLC ± - 4 PLC ± - ANGLES ± -		NAME		RECEPTACLE, FASTON, 4.75 $[\.187]$ SERIES	
MATERIAL #4H BRASS		FINISH SEE TABLE		PRODUCT SPEC	-
		APPLICATION SPEC	-		RESTRICTED TO
		WEIGHT	-		SIZE
		CUSTOMER DRAWING		A3 00779	CAGE CODE
		SCALE 5:1		C-60196	DRAWING NO
		SHEET 1 OF 1		REV P	