

THIS INFORMATION IS CONFIDENTIAL AND IS DISCLOSED TO YOU ON CONDITION THAT NO FURTHER DISCLOSURE IS MADE BY YOU TO OTHER THAN AMP PERSONNEL WITHOUT WRITTEN AUTHORIZATION FROM AMP INCORPORATED, HARRISBURG, PA.

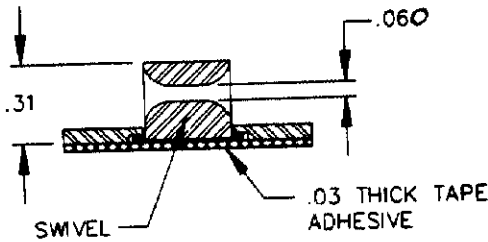
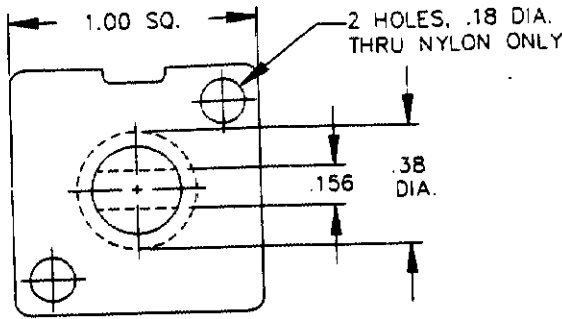

- NOTES:
1. ACCEPTS CABLE TIES WITH TENSILE VALUE UP TO 30 LBS. MAXIMUM.
  2. PACKAGED 100 PCS. PER POLY BAG. SEALED AND WITH LABEL OR PRINTED MARKING OF AMP NAME AND PART NUMBER.
  3. \* INACTIVE.

CUSTOMER DRAWING UNPUBLISHED

|           |                        |
|-----------|------------------------|
| 607847-2* | WITHOUT ADHESIVE       |
| 607847-1  | AS SHOWN WITH ADHESIVE |

|                       |  |  |  |                                  |              |
|-----------------------|--|--|--|----------------------------------|--------------|
| LOC<br>D              | PART No.   |  | DESCRIPTION                                      |                                  | ITEM         |
| DIST<br>1             | REVISION OF EACH ASSY NO. (WHEN BLANK, USE DWG REVISION) |  |  |                                  |              |
| QTY. REQ'D. PER ASSY. |  | PARTS LIST   |  |                                  |              |
|                       |  | MATERIAL<br>NYLON  | HEAT TREAT<br><i>nr</i>                          | FINISH<br><i>nr</i>              |              |
|                       |  | DIMEN: IN'S ARE IN INCHES  | DRAWN BY:<br>M.J. ZGLESZEWSKI                    | DATE:<br>8/20/90                 | APPROVED BY: |
|                       |  | TOLERANCES UNLESS OTHERWISE SPECIFIED:<br>2 PL DEC ± .02<br>3 PL DEC ± .01<br>4 PL DEC ± | CHECK BY:  | RELEASE:<br><i>J. Hamed 8/90</i> |              |
|                       |  | ANGLES ±   | <b>AMP</b>   AMP INCORPORATED<br>Harrisburg, Pa. |                                  |              |
|                       |  | SURF TEXTURE: <input checked="" type="checkbox"/>  |  |                                  |              |
|                       |  | REMOVE BURRS. BREAK SHARP EDGES. .015 R. MAX.  | NAME: CABLE TIE MOUNT SWIVEL BASE                |                                  |              |
|                       | C  | ECN 081590   | FH   | B-90                             |              |
| P                     | F  | LTR  | APP  | DATE                             |              |
| REVISION RECORD       |  | SCALE: A   | DRAWING No.:                                     | 607847                           | SHEET: 1:1   |
|                       |  |  |  | REV.:                            | C            |