

Distributed by:

**JAMECO**<sup>®</sup>  
ELECTRONICS

**www.Jameco.com ♦ 1-800-831-4242**

The content and copyrights of the attached  
material are the property of its owner.

Jameco Part Number 1975512

THIS DRAWING IS UNPUBLISHED. RELEASED FOR PUBLICATION  
 © COPYRIGHT BY TYCO ELECTRONICS CORPORATION. ALL RIGHTS RESERVED.

LOC	DIST	REVISIONS					
		P	LTR	DESCRIPTION	DATE	DWN	APVD
AD	00	F		EC 0G3C 0786 04	31-01-05	BSV	JLG

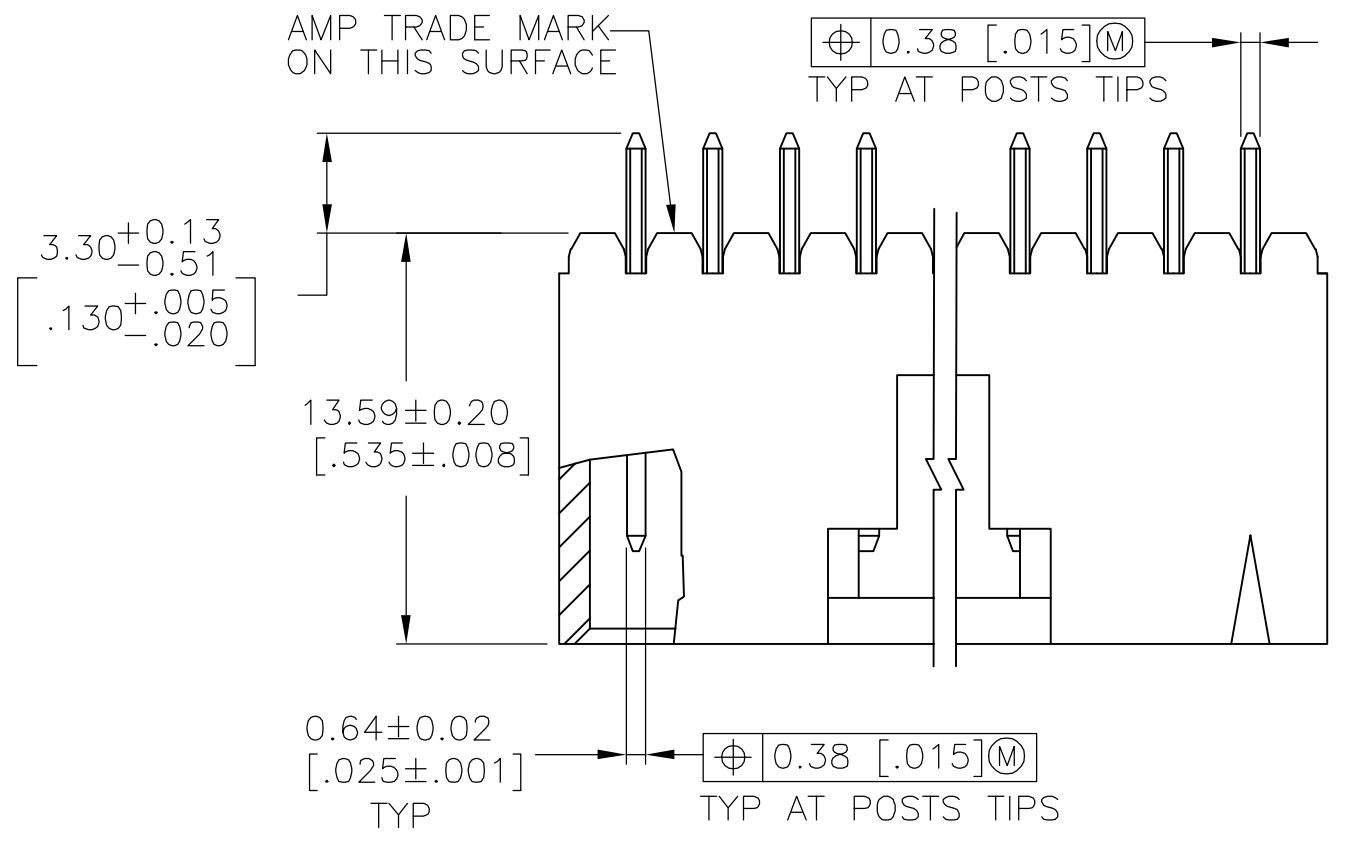

- 1 0.00038[.000015] GOLD IN THE CONTACT AREA, 0.00254-0.00508[.000100-.000200] MATTE TIN-LEAD ON THE SOLDER TAIL, ALL OVER 0.00127[.000050] NICKEL
- 2 POINT OF MEASUREMENT FOR PLATING THICKNESS
- 3 THE NOTED DIMENSIONS APPLY FROM THE BASIC DIMENSION LINE (NOT THE POST CENTERLINE) TO THE SURFACE INDICATED
- 4 ONE POLARIZATION SLOT FOR 2 POSITION ASSEMBLY ONLY.
- 5 DIMENSIONS NOTED ARE FOR SOLDER STENCIL LAYOUT FOR USE WITH  $1.57 \pm 0.02 [0.062 \pm .008]$  THICK PRINTED CIRCUIT BOARDS.
- 6 PARTS ARE PACKAGED IN GANG OF TUBES
- 7 0.00038[.000015] GOLD IN THE CONTACT AREA, 0.00254-0.00508[.000100-.000200] MATTE TIN ON THE SOLDER TAIL,

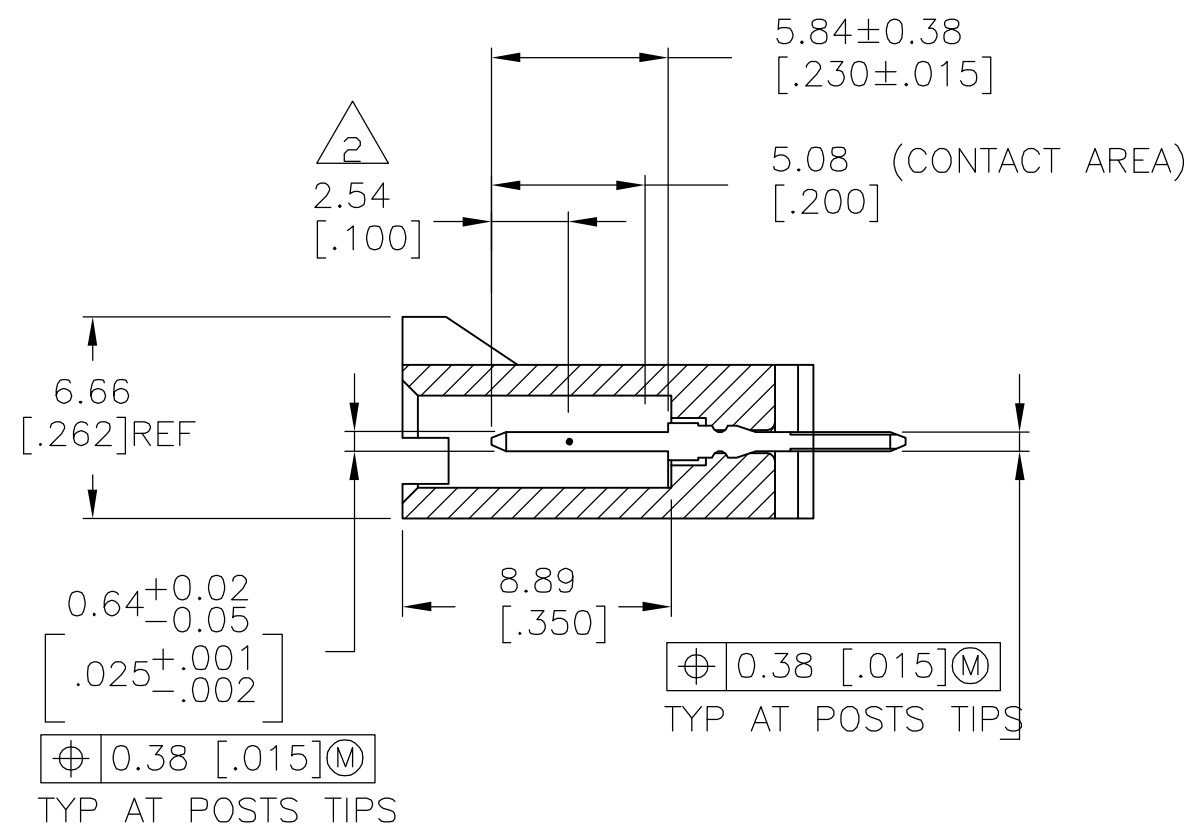
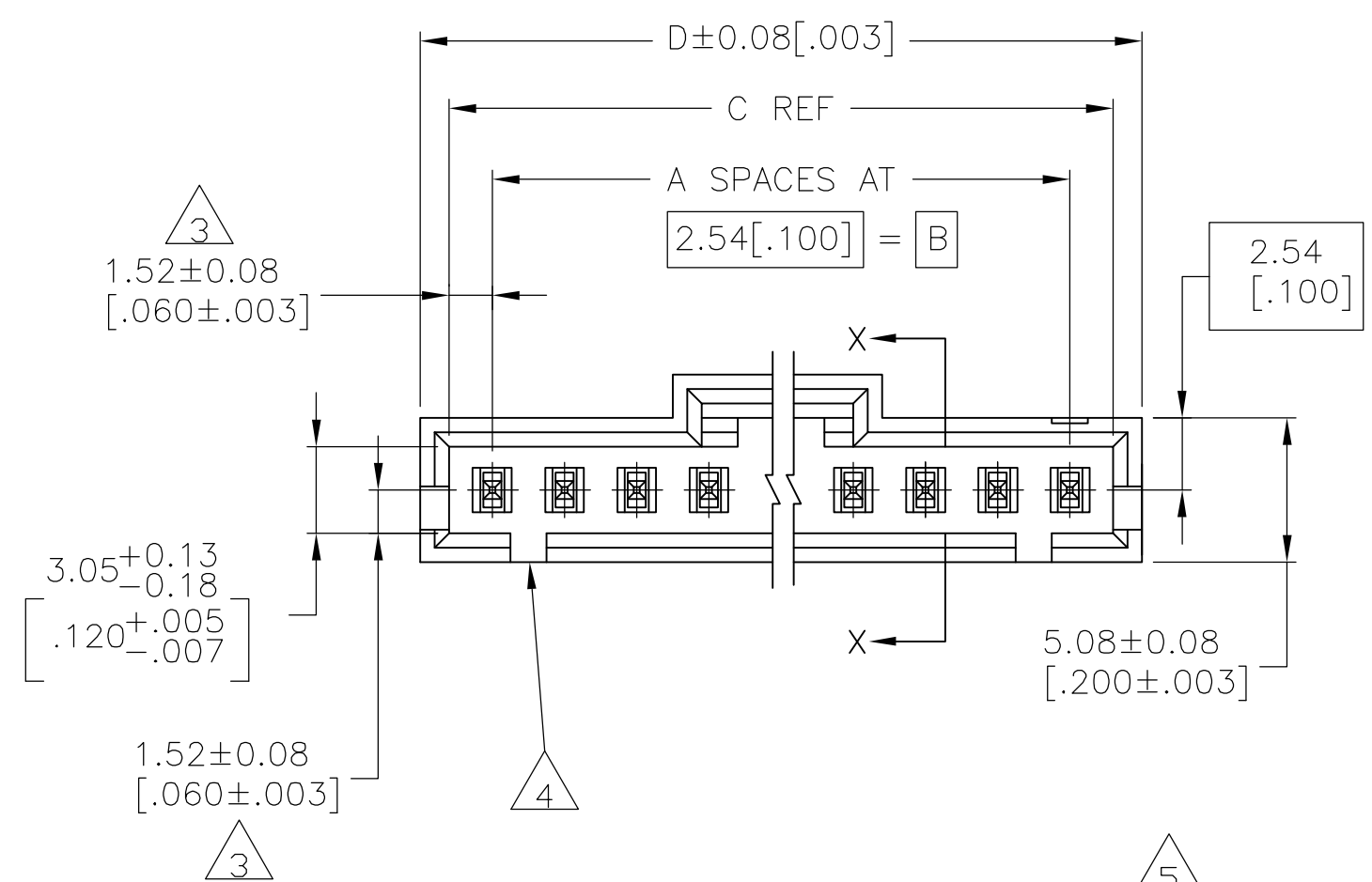

SECTION X - X

PLATING	D	C	B	A	NO OF POSN	PART NUMBER
7	66.04 [2.600]	64.01 [2.520]	60.96 [2.400]	24	25	7-104910-4
7	63.50 [2.500]	61.47 [2.420]	58.42 [2.300]	23	24	7-104910-3
7	60.96 [2.400]	58.93 [2.320]	55.88 [2.200]	22	23	7-104910-2
7	58.42 [2.300]	56.39 [2.220]	53.34 [2.100]	21	22	7-104910-1
7	55.88 [2.200]	53.85 [2.120]	50.80 [2.000]	20	21	7-104910-0
7	53.34 [2.100]	51.31 [2.020]	48.26 [1.900]	19	20	6-104910-9
7	50.80 [2.000]	48.77 [1.920]	45.72 [1.800]	18	19	6-104910-8
7	48.26 [1.900]	46.23 [1.820]	43.18 [1.700]	17	18	6-104910-7
7	45.72 [1.800]	43.69 [1.720]	40.64 [1.600]	16	17	6-104910-6
7	43.18 [1.700]	41.15 [1.620]	38.1 [1.500]	15	16	6-104910-5
7	40.64 [1.600]	38.61 [1.520]	35.56 [1.400]	14	15	6-104910-4
7	38.1 [1.500]	36.07 [1.420]	33.02 [1.300]	13	14	6-104910-3
7	35.56 [1.400]	33.53 [1.320]	30.48 [1.200]	12	13	6-104910-2
1	66.04 [2.600]	64.01 [2.520]	60.96 [2.400]	24	25	2-104910-4
1	63.50 [2.500]	61.47 [2.420]	58.42 [2.300]	23	24	2-104910-3
1	60.96 [2.400]	58.93 [2.320]	55.88 [2.200]	22	23	2-104910-2
1	58.42 [2.300]	56.39 [2.220]	53.34 [2.100]	21	22	2-104910-1
1	55.88 [2.200]	53.85 [2.120]	50.80 [2.000]	20	21	2-104910-0
1	53.34 [2.100]	51.31 [2.020]	48.26 [1.900]	19	20	1-104910-9
1	50.80 [2.000]	48.77 [1.920]	45.72 [1.800]	18	19	1-104910-8
1	48.26 [1.900]	46.23 [1.820]	43.18 [1.700]	17	18	1-104910-7
1	45.72 [1.800]	43.69 [1.720]	40.64 [1.600]	16	17	1-104910-6
1	43.18 [1.700]	41.15 [1.620]	38.1 [1.500]	15	16	1-104910-5
1	40.64 [1.600]	38.61 [1.520]	35.56 [1.400]	14	15	1-104910-4
1	38.1 [1.500]	36.07 [1.420]	33.02 [1.300]	13	14	1-104910-3
1	35.56 [1.400]	33.53 [1.320]	30.48 [1.200]	12	13	1-104910-2

RECOMMENDED PC BOARD MOUNTING DIMENSIONS  
 RECOMMENDED STENCIL THICKNESS = 0.25[.010]

THIS DRAWING IS A CONTROLLED DOCUMENT.

DWN E. BRANDBERG 10-13-94  
 CHK J. GESFORD 10-13-94  
 APVD D. DUPLER 10-13-94

TOLERANCES UNLESS OTHERWISE SPECIFIED:  
 0 PLC ± -  
 1 PLC ± -  
 2 PLC ± 0.13[.005]  
 3 PLC ± -  
 4 PLC ± -  
 ANGLES ± -

MATERIAL HOUSING: HIGH TEMPERATURE THERMOPLASTIC COLOR-BLACK POSTS: BRASS FINISH SEE TABLE

NAME: tyco Electronics Tyco Electronics Corporation Harrisburg, Pa 17105-3608

PRODUCT SPEC: -  
 APPLICATION SPEC: -  
 WEIGHT: -

SIZE: A2 CAGE CODE: 00779 DRAWING NO: C=104910 RESTRICTED TO: -

CUSTOMER DRAWING SCALE: 4:1 SHEET: 1 OF 1 REV: F