

BOARD-TO-BOARD COAXIAL CONNECTOR

CONTENTS

	Sheet
1. SCOPE.....	2
1.1 Introduction.....	2
1.2 Qualification.....	2
2. APPLICABLE DOCUMENTS	2
2.1 Tyco Electronics Documents.....	2
2.2 Commercial Standards.....	2
3. REQUIREMENTS	2
3.1 Design and Construction	2
3.2 Materials.....	3
3.3 Ratings	3
3.4 Characteristic Values	3
3.5 Performance and Test Description.....	3
3.6 Test Requirements and Procedures Summary	4
3.7 Additional Test and Measuring Details.....	6
3.8 Product Qualification and Requalification Test Sequence	9
4. QUALIFICATION TEST RESULTS	9
5. QUALITY ASSURANCE PROVISION.....	10
5.1 Qualification Testing.....	10
5.2 Requalification Testing.....	10
5.3 Acceptance.....	10
5.4 Quality Conformance Inspection	10

DR : R. Luppi

DATE : 07SEP05

APVD : D. Bozzer

DATE : 07SEP05

1. SCOPE

1.1 Introduction

This specification covers performance, test and quality requirements for the BOARD-TO-BOARD COAXIAL CONNECTOR. This coaxial connector is designed to handle severe mechanical misalignment between two printed circuit boards and is a surface mount device (SMD).

A single connector achieves the connection as the top board acts like the counterpart with its dedicated "target" layout.

Permitted radial misalignment is 0.8 mm; permitted axial misalignment is ± 1.0 mm from nominal stack height.

1.2 Qualification

When tests are performed on the subject product line, procedures specified in this Product Specification shall be used. All inspections shall be performed using applicable inspection plan and product drawing.

2. APPLICABLE DOCUMENTS

The following documents form a part of this specification to the extent specified herein. Unless otherwise specified, the latest edition of the document applies. In the event of conflict between requirements in this specification and the product drawing, the product drawing shall take precedence. In the event of conflict between the requirements in this specification and referenced documents, this specification shall take precedence.

2.1 Tyco Electronics Documents

- 619127: Drawing for connector with nominal PCB distance 14 mm
- 619134: Drawing for connector with nominal PCB distance 10 mm
- 619135: Drawing for connector with nominal PCB distance 6.65 mm
- 501-90021: Qualification Test Report
- 501-90024: Measurement Report

2.2 Commercial Standards

- EIA-364: Electrical Connector/Socket Test Procedures Including Environmental Classifications
- IEC 60512: Electromechanical Components For Electronic Equipment; Basic Testing. Procedures and Measuring Methods Part 1: General
- IEC 60068: Basic Environmental Testing Procedures For Electric Components And Electronic Equipment

3. REQUIREMENTS

3.1 Design and Construction

Product shall be of the design, construction and physical dimensions specified on the applicable product drawing.

3.2 Materials

Materials used in the construction of this product shall be as specified on the applicable product drawing.

3.3 Ratings

- Voltage: 125 volts AC
- Current: Signal application only
- Temperature: -40°C to +125°C
- Characteristic Impedance: 50 ohms
- Frequency Range: Up to 6 GHz

3.4 Characteristic Values

- Shielding Effectiveness: -60 dB max
- Parallel Stacking Height:
 - For PN 619127-1 : 14 mm (nominal)
 - For PN 619134-1 : 10 mm (nominal)
 - For PN 619135-1 : 6.65 mm (nominal)
- Radial Misalignment: ±0.8 mm max
- Axial Misalignment:
 - For PN 619127-1 : ±1.0 mm max
 - For PN 619134-1 : ±1.0 mm max
 - For PN 619135-1 : ±0.4 mm max
- Angle between Boards: ±2° max

3.5 Performance and Test Description

The product is designed to meet the electrical, mechanical and environmental performance requirements specified in Figure 1. Unless otherwise specified, all tests shall be performed at ambient environmental conditions per EIA-364.

3.6 Test Requirements and Procedures Summary

Ref.	Test Description	Performance, Requirements	Procedure
VISUAL			
C1	Initial examination of product.	Meets requirements of product and customer drawings.	IEC 60512-2 test 1a. Magnification 5x. Visual, dimensional and functional. Inspection per product and customer drawings.
C2	Final examination of product.	Meets visual requirements.	IEC 60512-2 test 1a. Magnification 5x. Visual inspection.
ELECTRICAL			
C3	Contact resistance.	<p><u>With gold-plated target board:</u></p> <ul style="list-style-type: none"> • Outer conductor: 10 milliohms maximum. • Center conductor: 20 milliohms maximum. <p><u>With tin-plated target board:</u></p> <ul style="list-style-type: none"> • Outer conductor: 20 milliohms maximum. • Center conductor: 100 milliohms maximum. 	IEC 60512-2-2a. Subject specimens to 100 milliamperes maximum and 20 millivolts maximum open circuit voltage. Measure with target board at maximum stack height. See Figure 2.
C4	VSWR 6.65mm 10mm 14mm	<1.2 up to 2.2 GHz <1.3 up to 3 GHz <1.2 up to 2.2 GHz <1.3 up to 3 GHz <1.2 up to 2.2 GHz <1.3 up to 3 GHz	Measure return loss up to 3'000 MHz at nominal and maximum misaligned positions, radially and axially. See Figure 3.
C5	Insertion loss. 6.65mm 10mm 14mm	<0.2 dB up to 2.2 GHz < 0.25 dB up to 3 GHz <0.2 dB up to 2.2 GHz < 0.25 dB up to 3 GHz <0.2 dB up to 2.2 GHz < 0.25 dB up to 3 GHz	Measure insertion loss up to 3'000 MHz at nominal and maximum misaligned positions, radially and axially. See Figure 3.
C6	Shielding effectiveness.	-60 dB maximum for $f \leq 2'500$ MHz	Absorbing Clamp Method in IEC 60096-1 Amendment 2.

Figure 1 (cont)

Ref.	Test Description	Performance, Requirements	Procedure
MECHANICAL			
C10	Vibration, sinus.	No discontinuities of 1 microsecond or longer duration. See Note.	IEC 60512-4-6d. Cycles: 10Hz-2000Hz-10Hz (1 cycle). 10-58Hz: Const. amplitude of 0.75 mm, 58-2000Hz: Const. acceleration of 100 m/s ² . Sweep rate: 1 octave / minute. Duration: 2 hours in each of 3 mutually perpendicular directions.
C11	Vibration, sinus.	See Note.	IEC 60512-4-6d. Cycles: 10Hz-500Hz-10Hz (1 cycle). 10-58Hz: Const. amplitude of 1.5 mm, 58-500Hz: Const. acceleration of 200 m/s ² . Sweep rate: 1 octave / minute. Duration: 2 hours in each of 3 mutually perpendicular directions.
C12	Mating force.	<ul style="list-style-type: none"> • Outer conductor: 2.5 to 10.0 N • Center conductor: 0.8 to 4.0 N 	Measure at maximum and minimum stack heights.
ENVIRONMENTAL			
C13	Rapid change of temperature.	See Note.	IEC 60512-6-11d. Subject specimens to 10 cycles between -40 and 105°C. Exposure time: 30 minutes
C15	Temperature life.	See Note.	IEC 60512-6-11i. Subject mated specimens to 125°C for 1000 hours.
C16	Mixed flowing gas. (SO ₂ /H ₂ S/Cl ₂ /NO ₂)	See Note.	IEC 60068-2-60, Test Ke, Method 4. Subject mated specimens for 10 days.

Figure 1 (end)

NOTE Shall meet visual requirements, show no physical damage, and meet requirements of additional tests as specified in the Product Qualification and Requalification Test Sequence shown in Figure 6.

3.7 Additional Test and Measuring Details

3.7.1 Contact Resistance

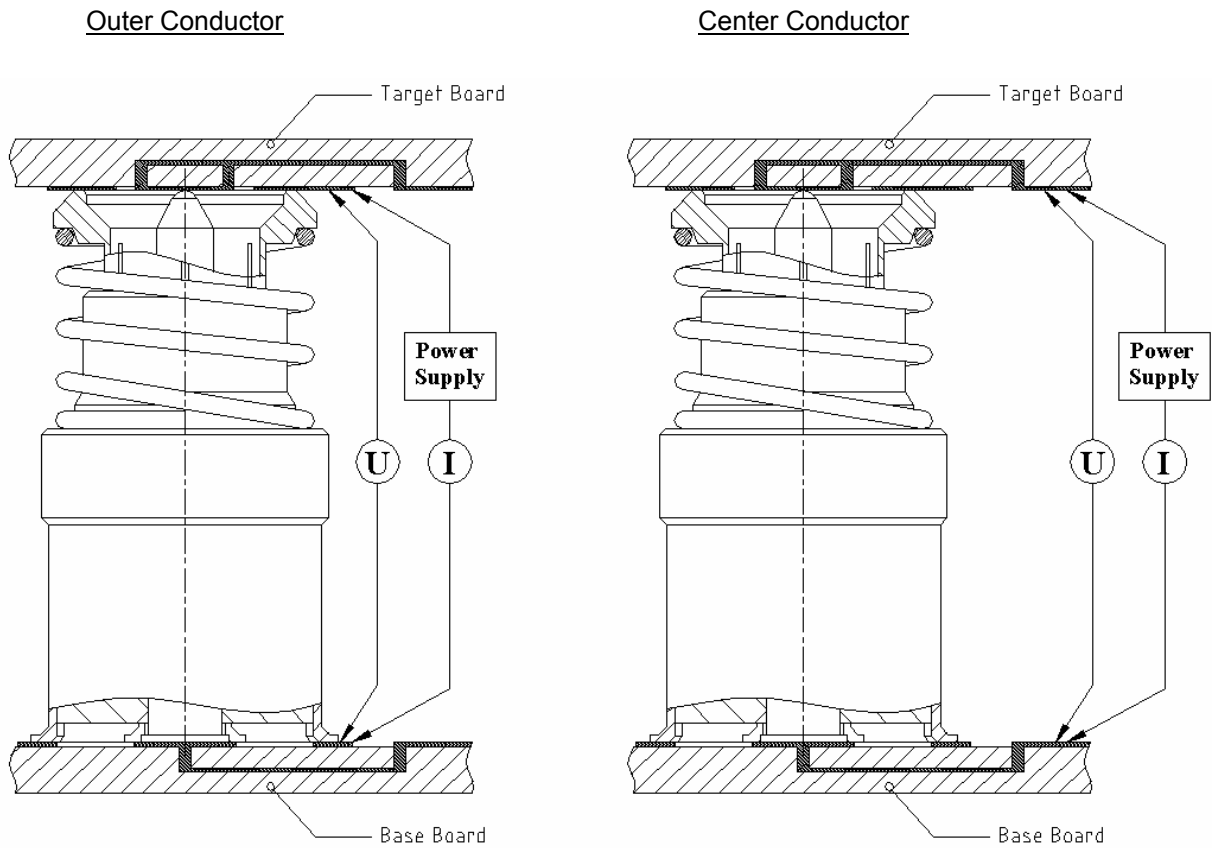

Figure 2

3.7.2 Return Loss and Insertion Loss

Calibration method:

- Actual frequency range on Network Analyser : 45 to 20.5 GHz
- Power: 10 dBm
- Number of measurement points: 401

- Calibration planes: A, B.
- Full 2 port calibration : open, short, load, thru, (isolation).

Measurement method:

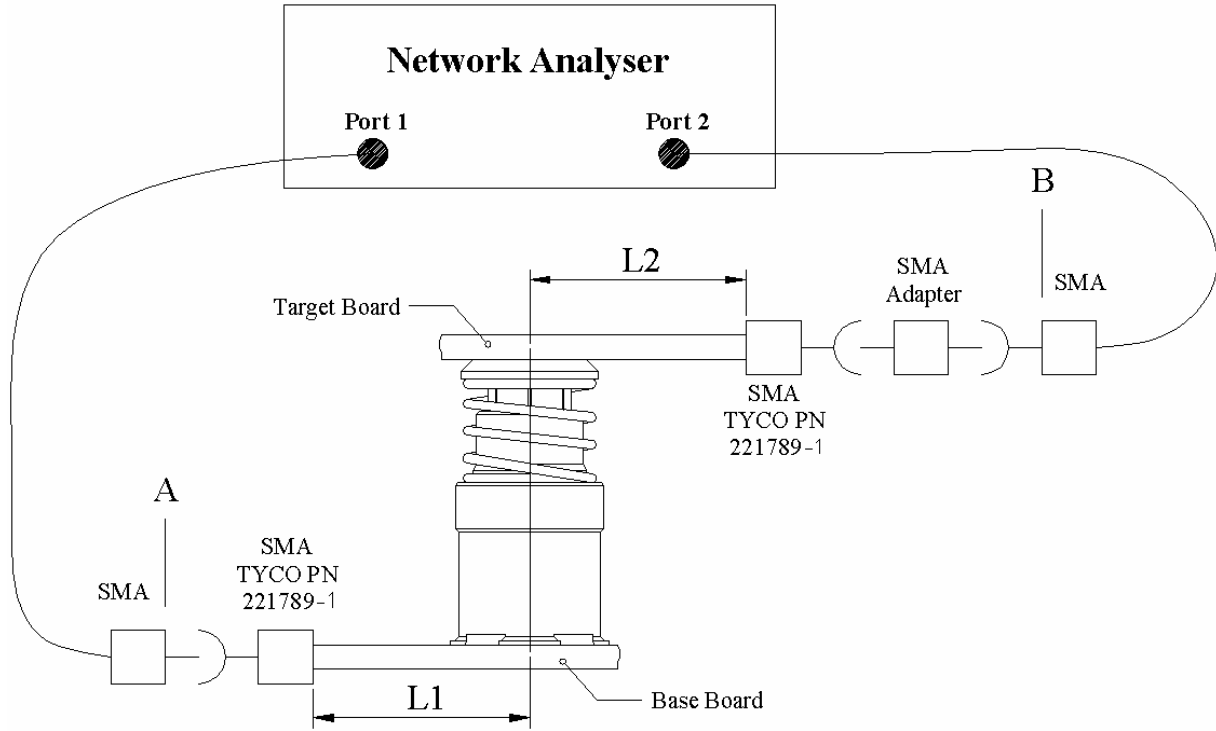

Figure 3

- Return loss:
Measurement without gating.
- Insertion loss:
Subtract 50 ohms line of reference board as shown in Figure 4 to isolate the share of the device under test.

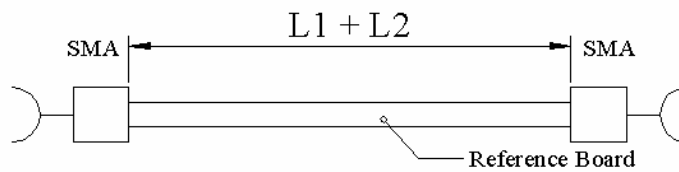

Figure 4

3.7.3 Resistance to Soldering Heat

Temperature profile:

The process parameters are described by a profile of the temperature in the IR oven. The standard profile is:

- pre-heat up at 160°C maximum
- soak zone of 1 min maximum (at 160°C)
- heat up for reflow zone to minimum 205°C (coldest point)
- maximum time above melting temperature 60 seconds

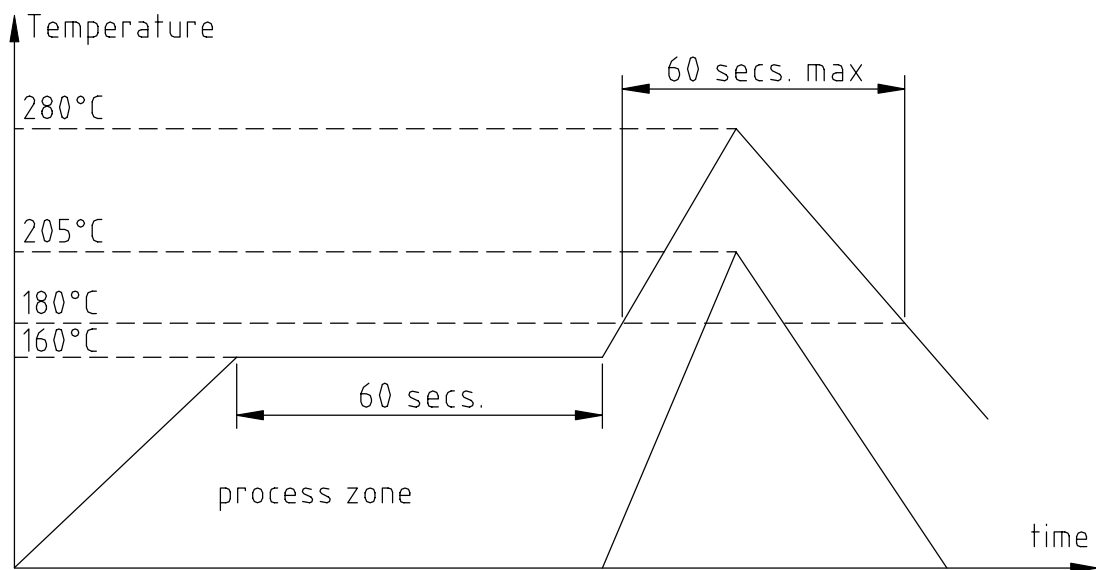

Oven temperature profile

Figure 5

NOTE Maximum temperature of component is 250°C.

The soldering cycle should be repeated twice, i.e. first soldered and second time shall stand for another time through the oven.

3.8 Product Qualification and Requalification Test Sequence

Test or Examination	Ref.	TEST-GROUP (c)							
		1a*	1b*	2a*	2b*	3a*	3b*	4	5
		TEST SEQUENCE (d)							
Initial examination of product	C1	1	1	1	1	1	1	1	1
Contact resistance	C3	2,6	2,6	3,6	3,6	2,4	2,4		
Return loss	C4							2	
Insertion loss	C5							3	
Shielding effectiveness	C6								2
Vibration, sinus (10g)	C10	5	5						
Vibration, sinus (20g)	C11	4	4						
Mating force	C12			2,5	2,5				
Rapid change of temperature	C13	3	3						
Temperature life	C15			4	4				
Mixed flowing gas	C16					3	3		
Final examination of product	C2	7	7	7	7	5	5		

- NOTES**
- a* With tin-plated (SnPb) target board
 - b* With gold-plated (Au) target board
 - (c) See paragraph 4.1.A.
 - (d) Numbers indicate sequence in which tests are performed.

Figure 6

All test-groups are performed with specimens soldered on PCB's.

Stack height (PCB setting):

- Test-group 1: Max
- Test-groups 2 & 3: Nominal during environmental test,
Max for contact resistance measurements
- Test-group 4: Nominal, Min, and Max
- Test-group 5: Nominal

4. QUALIFICATION TEST RESULTS

All requirements were met. Refer to Test Report 501-90021 and Measurement Report 500-90024 for detailed results.

5. QUALITY ASSURANCE PROVISIONS

5.1 Qualification Testing

A. Specimen Selection

Specimen shall be prepared in accordance with applicable Instruction Sheets and shall be selected at random from current production.

All test groups shall each consist of a minimum of 10 specimens P/N 619127-1 except test-group 4 for which a minimum of 5 specimens is required, and test-group 5 for which a minimum of 2 specimens is required.

B. Test Sequence

Qualification inspection shall be verified by testing specimens as specified in Figure 6.

5.2 Requalification Testing

If changes significantly affecting form, fit or function are made to product or manufacturing process, product assurance shall coordinate requalification testing, consisting of all or part of original testing sequence as determined by development/product, quality and reliability engineering.

5.3 Acceptance

Acceptance is based on verification that product meets requirements of Figure 1. Failures attributed to equipment, test setup, customer supplied components or operator deficiencies shall not disqualify the product. If product failure occurs, corrective action shall be taken and samples resubmitted for qualification. Testing to confirm corrective action is required before resubmittal.

5.4 Quality Conformance Inspection

The applicable quality inspection plan shall specify the sampling acceptable quality level to be used.

Dimensional and functional requirements shall be in accordance with applicable product drawing and this specification.