

NOTE



All numerical values are in metric units [with U.S. customary units in brackets]. Dimensions are in millimeters [and inches]. Unless otherwise specified, dimensions have a tolerance of ± 0.13 [$\pm .005$] and angles have a tolerance of $\pm 2^\circ$. Figures and illustrations are for identification only and are not drawn to scale.

1. INTRODUCTION

This specification covers the requirements for application of FASTON 110 Series flag receptacles for wire-to-wire applications. Each receptacle features a wire barrel with a lip that, when crimped, wraps around and captures the wire. The wire barrel forms the “F” crimp which provides reliable electrical and mechanical performance. The wire barrel also features serrations that help retain the wire to the receptacle after crimping. These receptacles are available with or without an insulation support barrel. The receptacles are available with a stock thickness of 0.25 mm [.010 in.] or 0.30 mm [.012 in.].

The receptacles accept a mating tab with a width of 2.79 mm [.110 in.] (the series designator) with a thicknesses of 0.51 mm [.020 in.] or 0.81 mm [.032 in.]; receptacles with a wrap-around insulation support barrel also accept thicknesses of 0.41 mm [.016 in.] and 0.64 mm [.025 in.]. Each receptacle features a round detent that, when mated, engages the mating tab to provide the required retention force.

These receptacles are available in reeled form for terminating with automatic and semi-automatic machines.

When corresponding with TE Personnel, use the terminology provided in this specification to facilitate your inquiries for information. Basic terms and features of this product are provided in Figure 1.

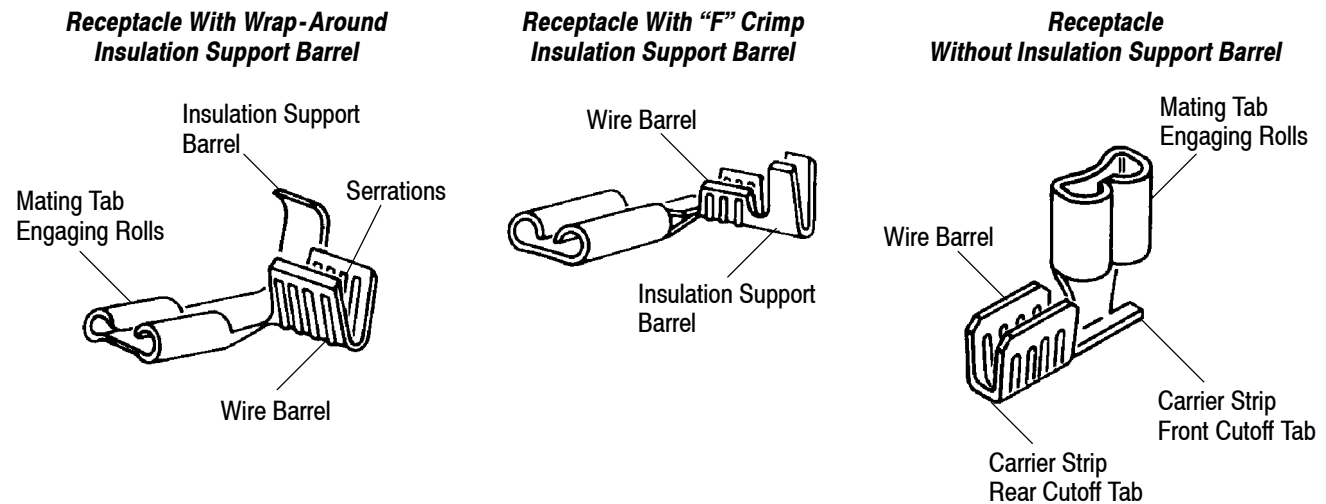

Figure 1

2. REFERENCE MATERIAL

2.1. Revision Summary

- Updated document to corporate requirements

2.2. Customer Assistance

Reference Product Base Part Number 61372 and Product Code 1091 are representative of FASTON 110 Series flag receptacles. Use of these numbers will identify the product line and expedite your inquiries through a service network established to help you obtain product and tooling information. Such information can be obtained through a local TE Representative or, after purchase, by calling PRODUCT INFORMATION at the bottom of this page.

2.3. Drawings

Customer Drawings for product part numbers are available from the service network. If there is a conflict between the information contained in the Customer Drawings and this specification or with any other technical documentation supplied, call PRODUCT INFORMATION at the number at the bottom of page 1.

2.4. Specifications

Application Specification (114-series) provides product description and application requirements. Documents available which pertain to this product are:

114-2032	FASTON Reversible Flag Receptacles
114-2036	FASTON Straight Receptacles with “F” Crimp Feature
114-2070	FASTON AMPLIVAR* Contact Tab
114-2078	FASTON Flag Receptacles with Tab-Lok Feature
114-2079	FASTON Flag Receptacles with “F” Crimp Feature
114-2082	FASTON Piggyback Receptacles
114-2126	FASTON Flag Receptacles with “F” Crimp Center-Strip Feature

2.5. Instructional Material

Instruction Sheets (408-series) provide product assembly instructions or tooling setup and operation procedures and Customer Manuals (409-series) provide machine setup and operation procedures. Documents available which pertain to this product are:

408-3295	Preparing Reels for Applicator Tooling
408-8024	Miniature Quick-Change Applicators (End-Feed Type)
408-8039	Heavy Duty Miniature Quick-Change Applicators (End-Feed Type)
409-5128	Basic AMP-O-LECTRIC* Model “K” Terminating Machines 471273-[]
409-5579	Split-Cycle Model “T” Terminating Unit 812059-[]
409-5792	AMP-O-LECTRIC Model “K-II” and “K-IIA” Terminating Machines 852070-[]
409-5842	AMP-O-LECTRIC Model “G” Terminating Machines 354500-[]

3. REQUIREMENTS

3.1. Safety

Do not stack product shipping containers so high that the containers buckle or deform.

3.2. Storage

A. Ultraviolet Light

Prolonged exposure to ultraviolet light may deteriorate the chemical composition used in the receptacle material.

B. Shelf Life

The receptacles should remain in the shipping containers until ready for use to prevent deformation. The receptacles should be used on a first in, first out basis to avoid storage contamination that could adversely affect performance.

C. Chemical Exposure

Do not store receptacles near any chemical listed below as they may cause stress corrosion cracking.

Alkalies	Ammonia	Citrates	Phosphates	Citrates	Sulfur Compounds
Amines	Carbonates	Nitrites	Sulfur	Nitrites	Tartrates

3.3. Wire Selection and Preparation

The receptacles will accept stranded wire sizes 26 through 16 AWG with an insulation diameter range of 1.02 through 2.54 mm [.040 through .100 in.]. Proper strip length is necessary to properly insert the wire into the wire barrel. The strip length of the wire is shown in Figure 2.



Reasonable care must be taken not to nick, scrape, or cut any part of the wire during the stripping operation.

Recommended Strip Length

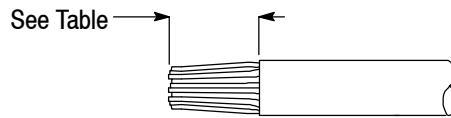

Note: Not to Scale

RECEPTACLE	WIRE		
	SIZE RANGE (AWG)	INSULATION DIAMETER RANGE	STRIP LENGTH ±0.38 [±.015]
With Wrap-Around Insulation Support Barrel	22-18	1.65-2.54 [.065-.100]	5.08 [.200]
With "F" Crimp Insulation Support Barrel	26-18	1.02-2.54 [.040-.100]	4.78 [.188]
Without Insulation Support Barrel	22-16	—	5.58 [.220]

Figure 2

3.4. Crimp Requirements

A. Cutoff Tab and Burr

Cutoff tabs (front and rear) are the remaining portion of the carrier strip after the receptacle is cut from the carrier strip. The following dimensional requirements will ensure proper application.

1. The cutoff tabs must not exceed the dimension shown in Figure 3.
2. The burr resulting from the cutoff tab shearing must not exceed the dimension shown in Figure 3.

B. Wire Barrel Crimp

The crimp applied to the wire barrel portion of the receptacle is the most compressed area and is most critical in ensuring optimum electrical and mechanical performance. The wire insulation must not enter the wire barrel. See Figure 3.

C. Wire Barrel Seam

The seam between the two sides of the wire barrel must be completely closed, and there must be no evidence of loose wire strands or wire strands visible in the seam. See Figure 3.

D. Wire Barrel Flash

Wire barrel flash is the formation that may appear on both sides of the wire barrel as the result of the crimping process. It must not exceed the dimension provided in Figure 3.

E. Bellmouths

The front and rear bellmouth lengths must be within the dimensions given in Figure 3.

F. Insulation Support Barrel Crimp

For receptacles with wrap-around insulation support barrel, the insulation support barrel must be firmly wrapped around the wire insulation without cutting into the insulation, and the tip of the barrel must not touch the floor of the receptacle. For receptacles with "F" crimp insulation support barrel, the seam between the two sides of the barrel must be completely closed, and there must be no evidence of wire insulation visible in the seam. See Figure 3.

G. Wire Conductor and Insulation Location

All wire conductors must be held firmly inside the wire barrel. No strands can be folded back over the wire insulation. The wire insulation must not enter the wire barrel. Conductor ends must be flush with, or extend slightly beyond, the end of the wire barrel to the maximum given in Figure 3.

For receptacles with an insulation support barrel, both the wire conductor and insulation must be visible between the wire barrel and insulation support barrel. See Figure 3.

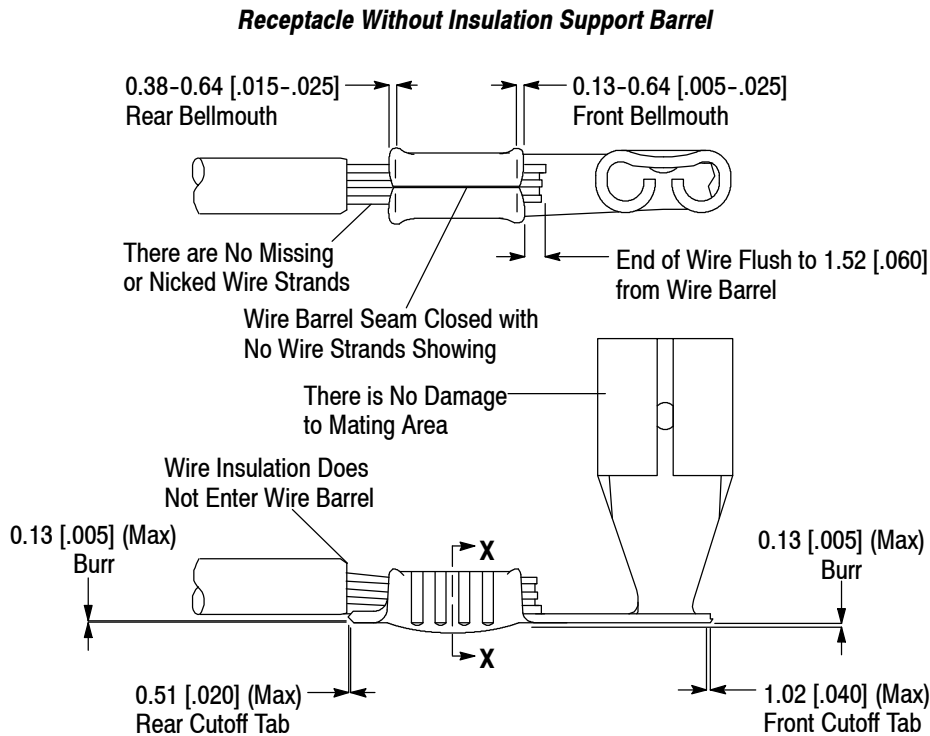
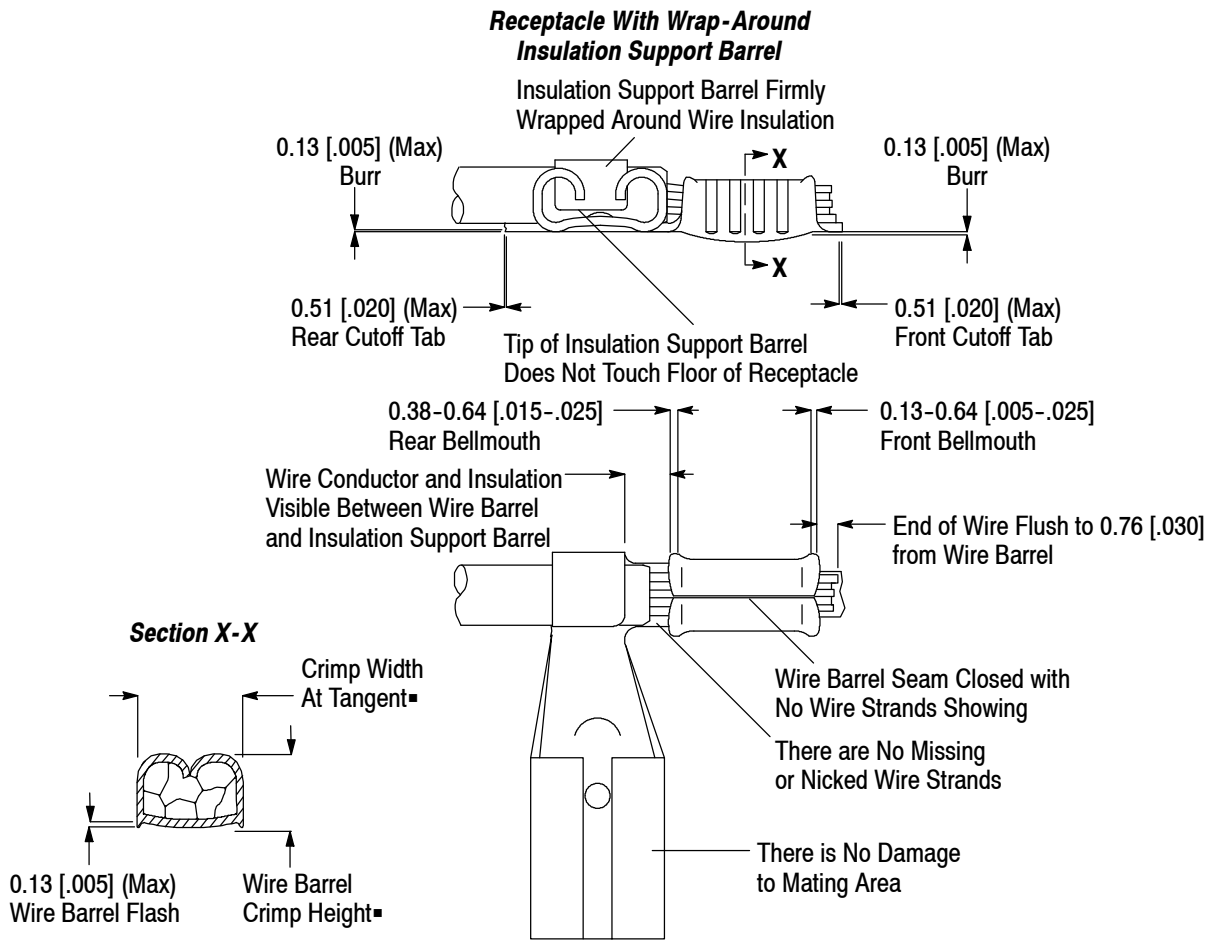

▪ Refer to Applicator Log for Dimension; Refer to Section 5 for Applicator

Figure 3 (Cont'd)

**Receptacle With "F" Crimp
Insulation Support Barrel**

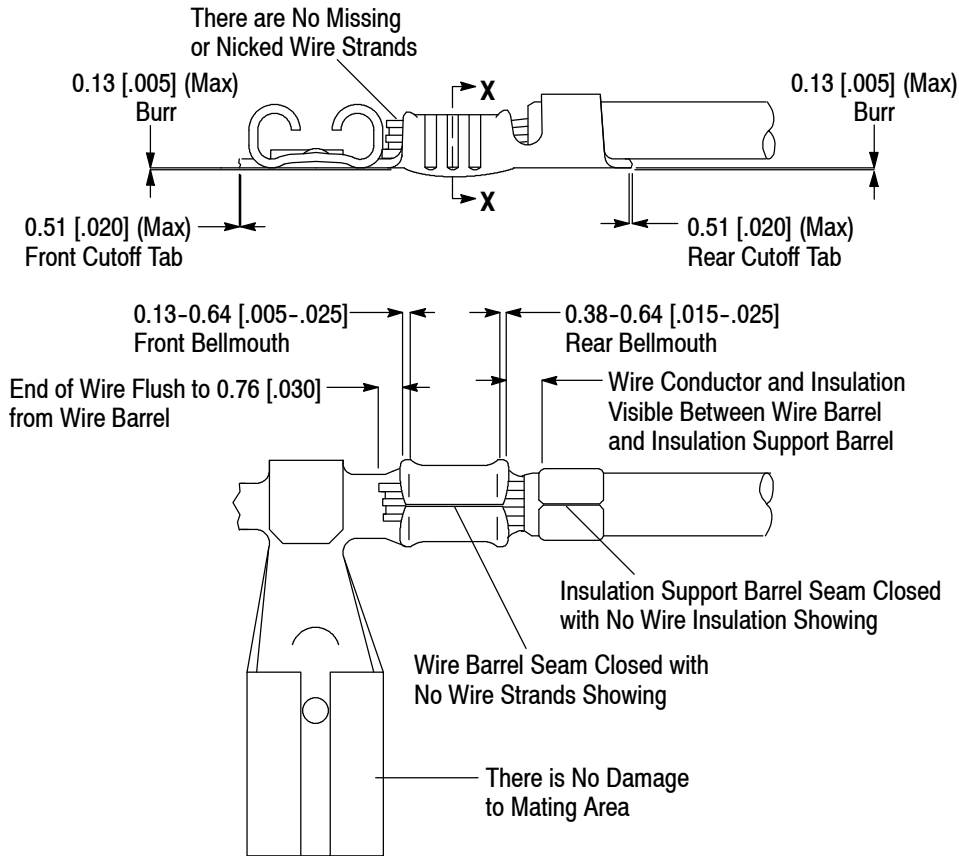

Figure 3 (end)

H. Twist and Roll

There may be twist or roll of the wire barrel to a maximum of 10° to either side. See Figure 4.

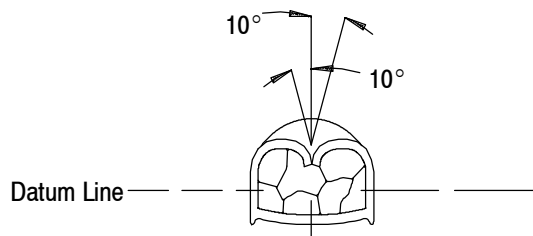
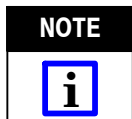

Figure 4

I. Tensile Strength (Force for Crimp Pull-Out Test)

Crimped receptacles must hold the wire firmly and have a crimp pull-out test value meeting that specified in Figure 5.



The tensile testing machine must be adjusted for head travel of 25.4 mm [1.0 in.] per minute. Force must be directly and gradually applied for one minute.

WIRE SIZE (AWG)	TENSILE FORCE (N [lb]) Min ^a
22	36 [8]
20	58 [13]
18	89 [20]
16	133 [30]

- ^a This force does not include holding force of the insulation support barrel crimp.

Figure 5

J. Bend Allowance

The force applied during crimping may cause some bending between the wire barrel and wire. Such deformation is acceptable within the following limits.

1. Side-to-Side

The crimped portion must not be bent from one side to the other beyond the limits shown in Figure 6.

2. Up and Down

The crimped portion must not be bent beyond the limits shown in Figure 6.

**With Wrap Around or "F" Crimp
Insulation Support Barrel**

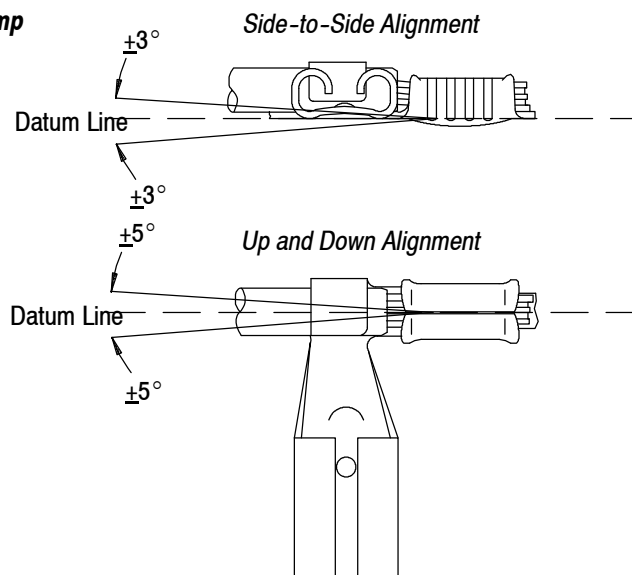

Without Insulation Support Barrel

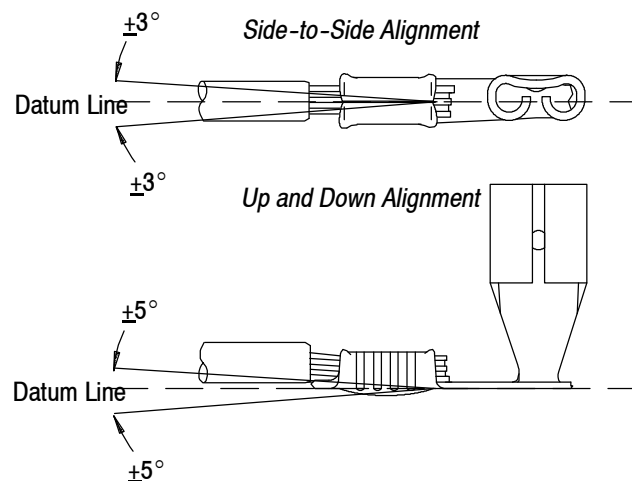
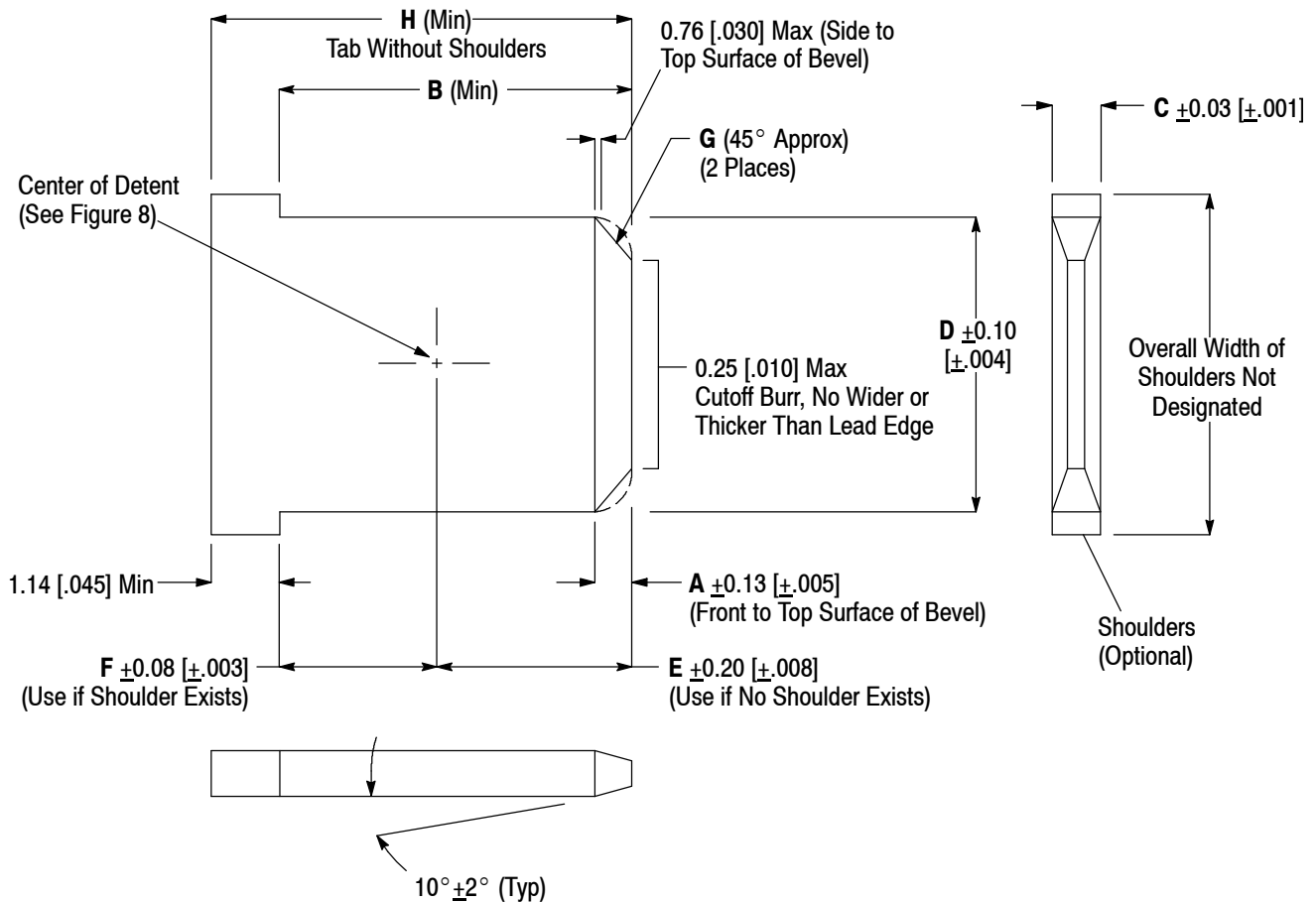

Figure 6

3.5. Mating Tab Dimensions

Features and dimensional requirements for the mating tabs are shown in Figure 7.



Notes:

- 1 Bevel may be a straight line or a radius within Dimension G ± 0.51 mm [$\pm .020$ in.].
- 2 Tab shall be flat (0.03 mm/mm [$.001$ in./in.]) and free from burrs greater than 10% of tab thickness or raised plateaus, except for testing as described in Paragraph 3.7.
- 3 Measurements shall not include plating, burrs, or flatness tolerance.

MATING TAB WIDTH AND THICKNESS (Nominal) AND DETENT TYPE	DIMENSION							
	A	B	C	D	E	F	G	H
2.79 × 0.51 [.110 × .020] With Dimple or Hole	0.51 [.020]	6.98 [.275]	0.51 [.020]	2.79 [.110]	1.57 [.062]	5.54 [.218]	0.89 [.035]	8.13 [.320]
2.79 × 0.81 [.110 × .032] With Dimple or Hole	0.51 [.020]	6.98 [.275]	0.81 [.032]	2.79 [.110]	1.57 [.062]	5.54 [.218]	0.89 [.035]	8.13 [.320]

Figure 7

3.6. Mating Tab Detent

A mating tab having no locking feature may be used for applications where low mating retention forces are desirable. Where higher forces are sought, a mating tab with a detent meeting the requirements shown should be used. Holes provide the greatest retention forces, while dimples provide acceptable medium-range forces. Refer to Figure 8.

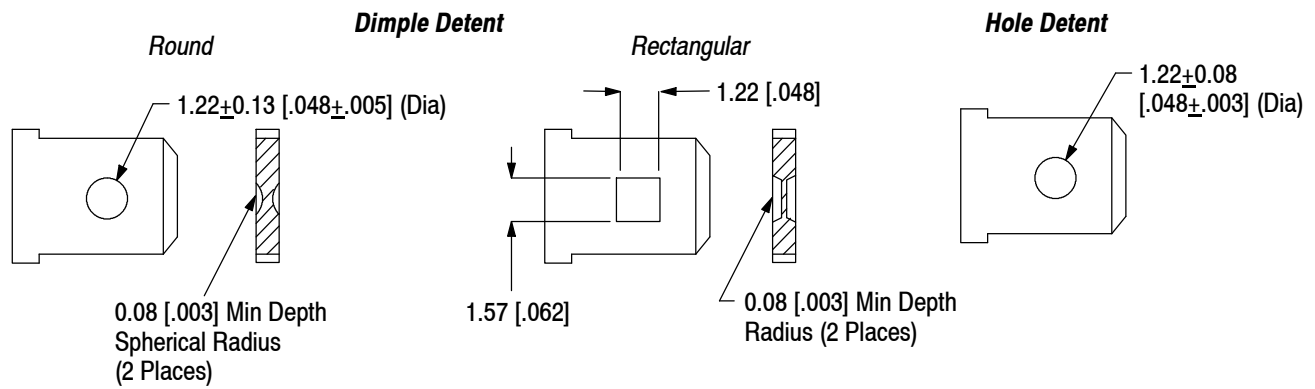

Note: Detents may be at the same location on the longitudinal centerline if no shoulder or obstruction is present at the base of the tab.

Figure 8

3.7. Mating Overcycle and Testing

The force required to mate and unmate test mating tab and receptacle must be measured using a testing device capable of holding the reading. It must also provide accurate alignment with slow and steady mating and unmating of the test mating tab and receptacle. Force shall be as specified in Figure 9.

NOTE

The mating tabs may be tested according to National Electrical Manufacturers Association (NEMA) DC 2 “Residential Controls—Quick-Connect Terminals.” Test mating tabs shall be dimensioned as shown in Figures 7 and 8 of this specification, except that the tab thickness (Dimension C in Figure 7) shall have a tolerance of ± 0.008 mm [$\pm .0003$ in.] for brass tabs and ± 0.013 mm [$\pm .0005$ in.] for steel tabs; and raised plateaus around detents shall be limited to a total of 0.025 mm [.001 in.] for both sides.

FORCE (N [lb]) ^a				
FIRST MATING (Max) INDIVIDUAL	FIRST UNMATING (Min)		SIXTH UNMATING (Min)	
	AVERAGE	INDIVIDUAL	AVERAGE	INDIVIDUAL
53.37 [12]	13 [3]	9 [2]	9 [2]	4.45 [1]

- ^a Mating with unplated or plated receptacle

Figure 9

3.8. Repair

CAUTION



Damaged or defective receptacles **MUST NOT** be used.

4. QUALIFICATION

FASTON 110 Series Flag Receptacles meet the requirements in Underwriters Laboratories Inc. (UL)-310 for quick-connect terminals, Listed by UL in File E 66717, and Certified by CSA International in File LR 7189A-509.

5. TOOLING

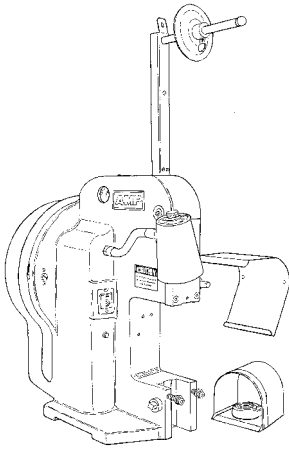
It is not recommended to use hand crimping tools to crimp flag receptacles. Machines for power assisted application of reeled receptacles are available to cover the full wire size range. Tooling part numbers and instructional material packaged with the tooling are shown in Figure 10.



AMP-O-LECTRIC Model "K"
Terminator Machine
1-471273-3 (409-5128)

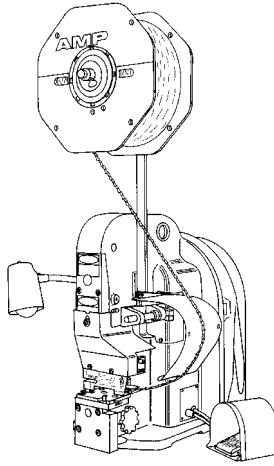

AMP-O-LECTRIC Model "K-II"
and "K-IIA" Terminating Machines
852070-[] (409-5792)

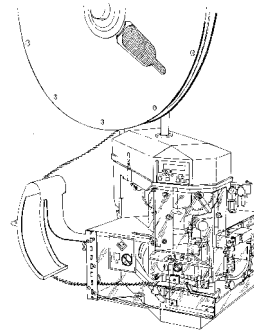

AMP-O-LECTRIC Model "G"
Terminating Machines 354500-[]
(409-5842)

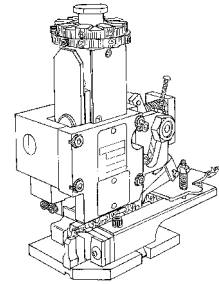

Heavy Duty Miniature
Quick-Change Applicators
(See Table) (408-8039)

RECEPTACLE		APPLICATOR	
DESCRIPTION	STOCK THICKNESS	AMP-O-LECTRIC Models "K", "K-II", or "K-IIA" Terminator Machine	AMP-O-LECTRIC Model "G" Terminator Machine
With Wrap-Around Insulation Support Barrel	0.25 [.010]	466299-4	466299-5
	0.30 [.012]		
With "F" Crimp Insulation Support Barrel	0.25 [.010]	466415-2	466415-1
	0.30 [.012]	1385495-2	1385495-1
Without Insulation Support Barrel	0.25 [.010]	466377-2	466377-1
	0.30 [.012]	687790-2	687790-1

Figure 10

6. VISUAL AID

Figure 11 shows a typical application of FASTON 110 Series Flag Receptacles. This illustration should be used by production personnel to ensure a correctly applied product. Applications which DO NOT appear correct should be inspected using the information in the preceding pages of this specification and in the instructional material shipped with the product or tooling.

Note: The information given in this figure applies to all receptacles shown, unless stated otherwise.

RECEPTACLE WITH WRAP-AROUND INSULATION SUPPORT BARREL

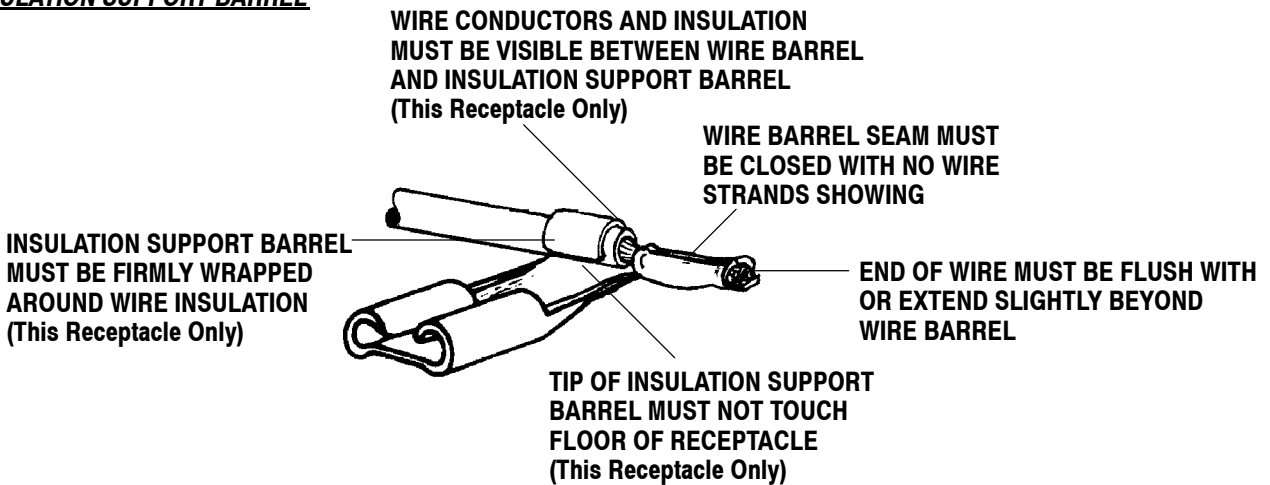

RECEPTACLE WITH "F" CRIMP INSULATION SUPPORT BARREL

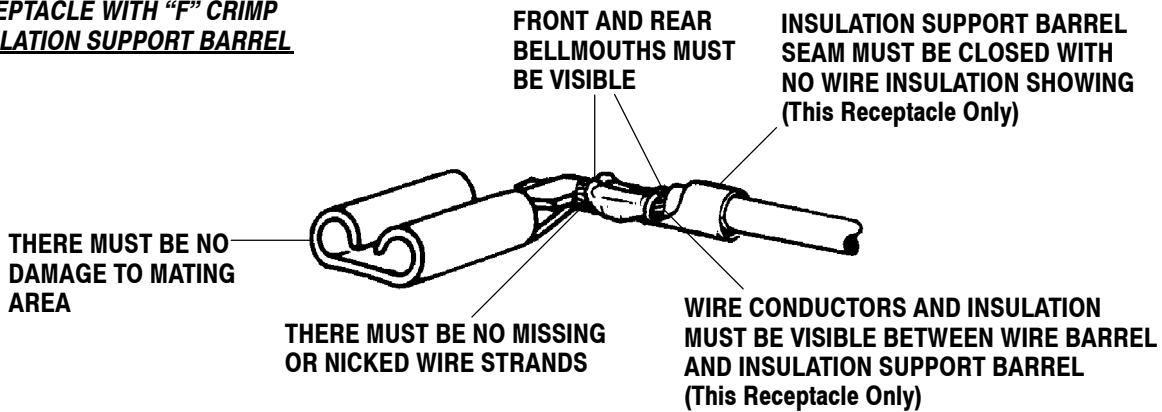

RECEPTACLE WITHOUT INSULATION SUPPORT BARREL

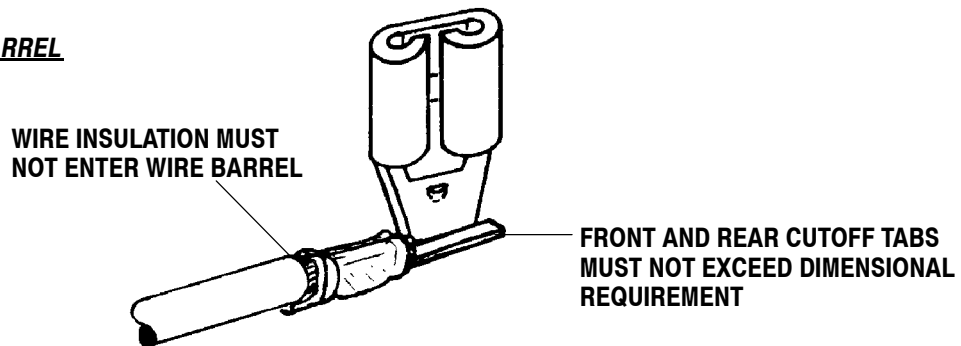

FIGURE 11. VISUAL AID