

Distributed by:



[www.Jameco.com](http://www.Jameco.com) ♦ 1-800-831-4242

The content and copyrights of the attached material are the property of its owner.

LOC		DIST		P		ZONE		LTR		REVISIONS		DATE	APPD
CM	54							R		REVISED PER ECN CM-3938	9-15-92	K5	RS

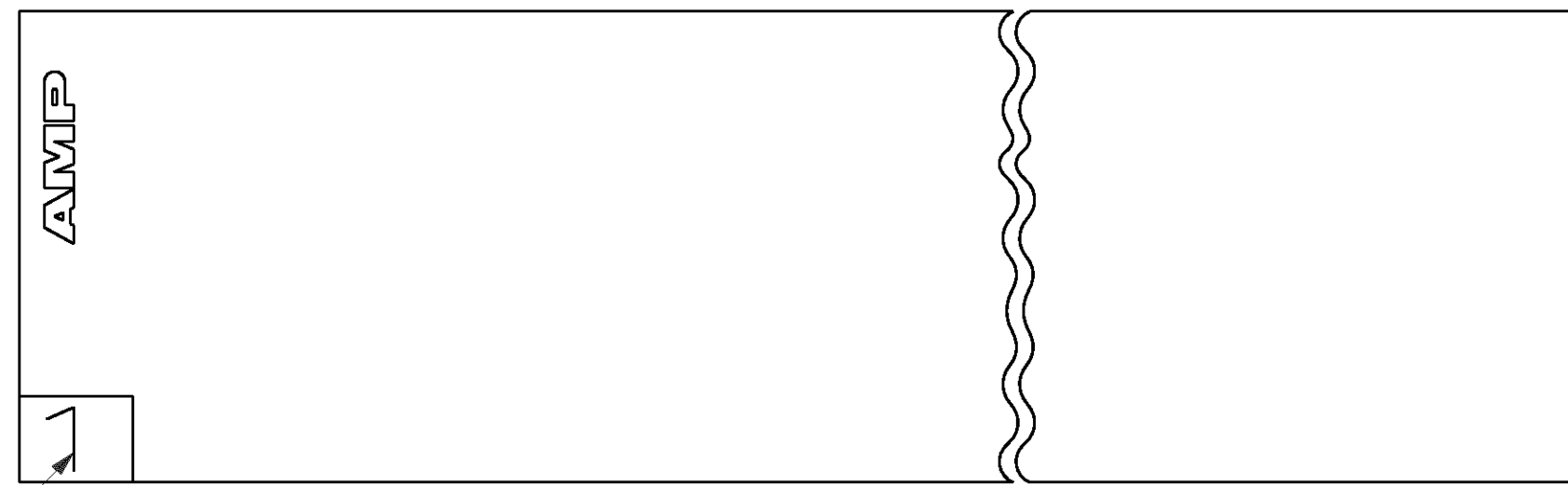

1. UNIT ACCEPTS 1.14 [.045] SQUARE OR ROUND POST.
2. UNIT ACCEPTS STANDARD SL-156 CONTACTS.
3. UNIT ACCEPTS KEYING PLUG 640254-1 AND KEYING PIN 640255-1.
4. CIRCUIT I.D. NUMBER(S) TO BE LOCATED SEQUENTIALLY AS SHOWN OR ONLY NO. 1 CIRCUIT PLACED ON TOP OF HOUSING.
5. DIMENSIONS IN BRACKETS ARE IN INCHES.

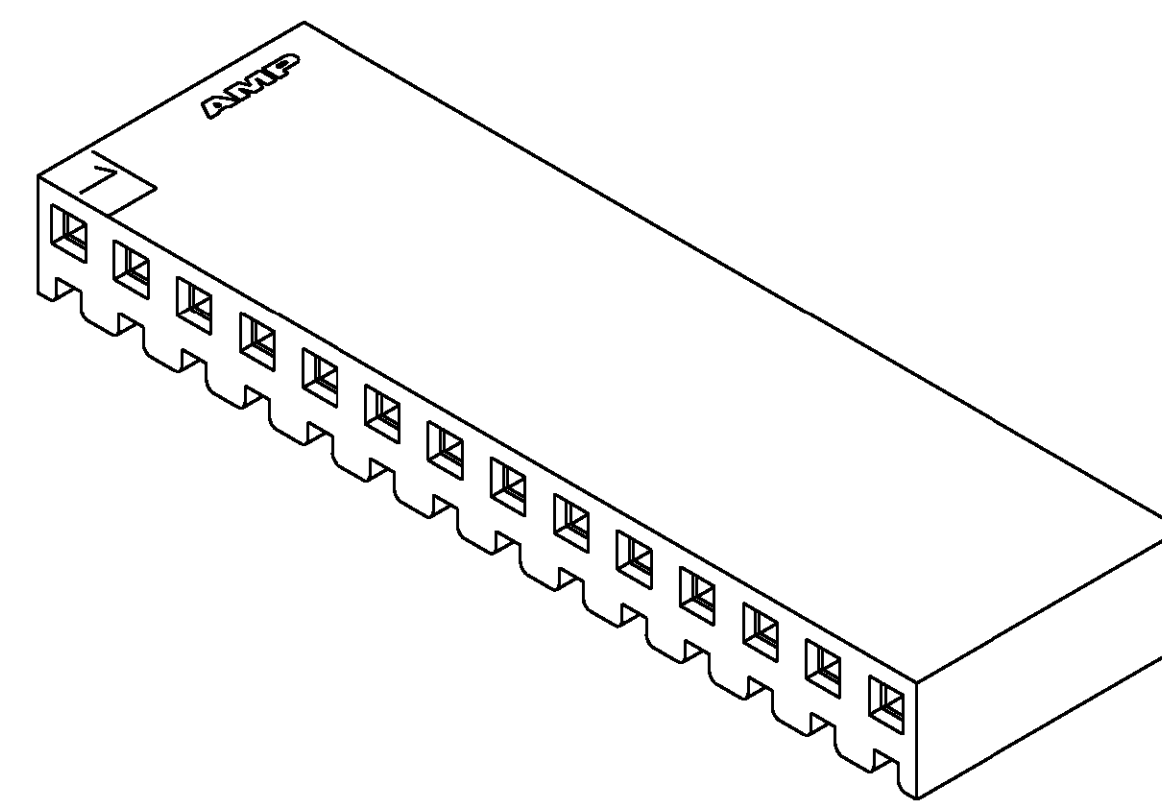
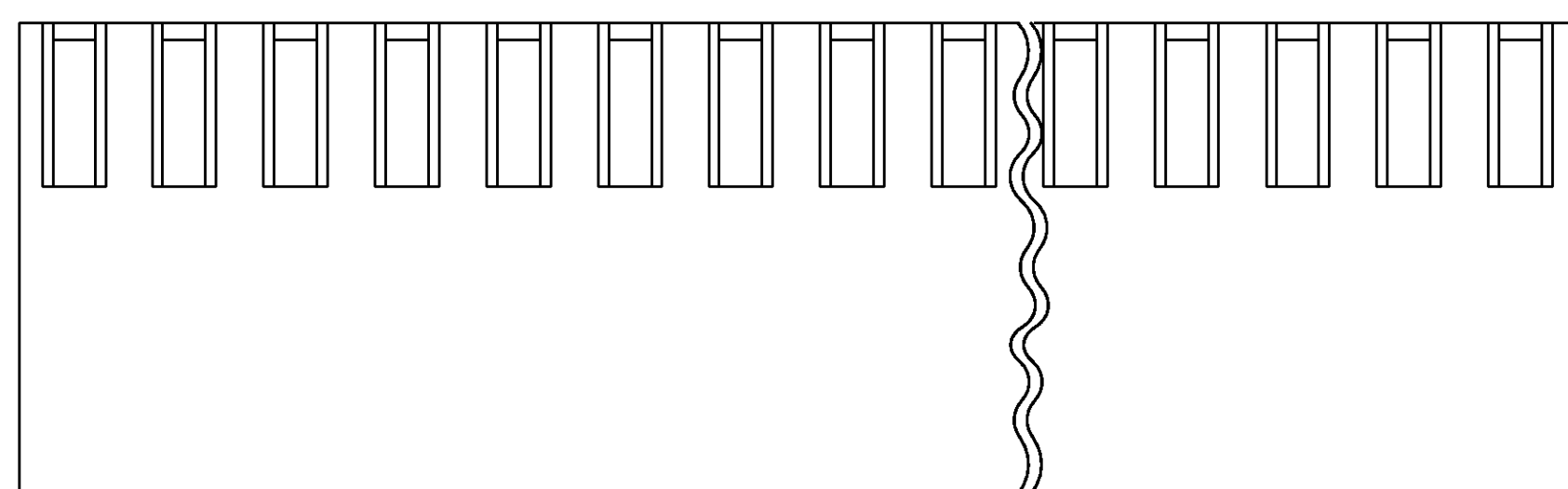
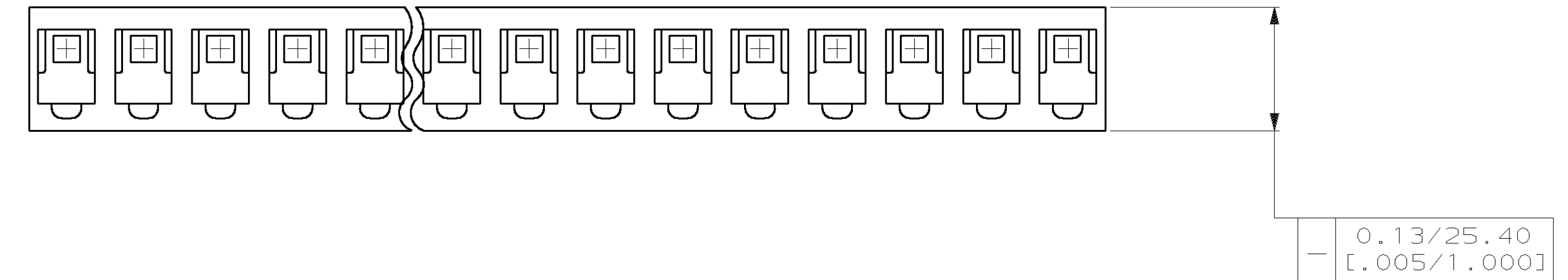
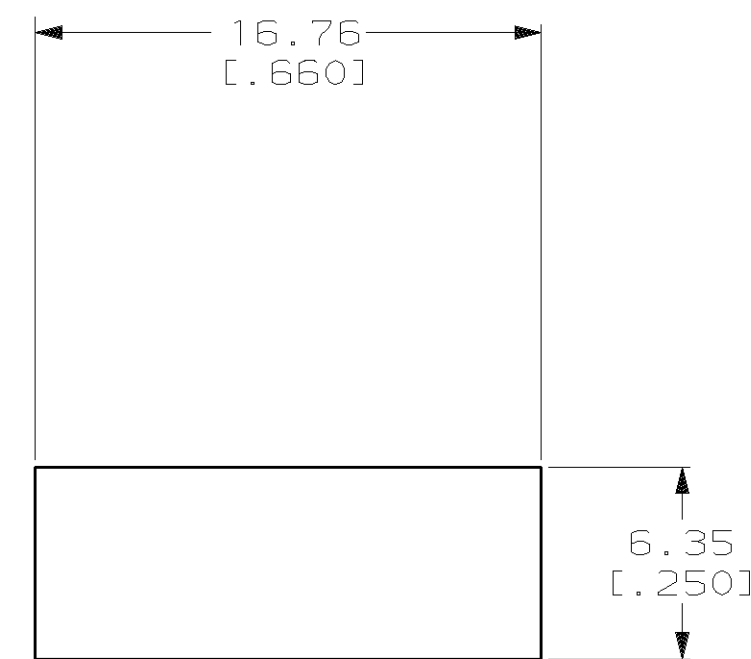
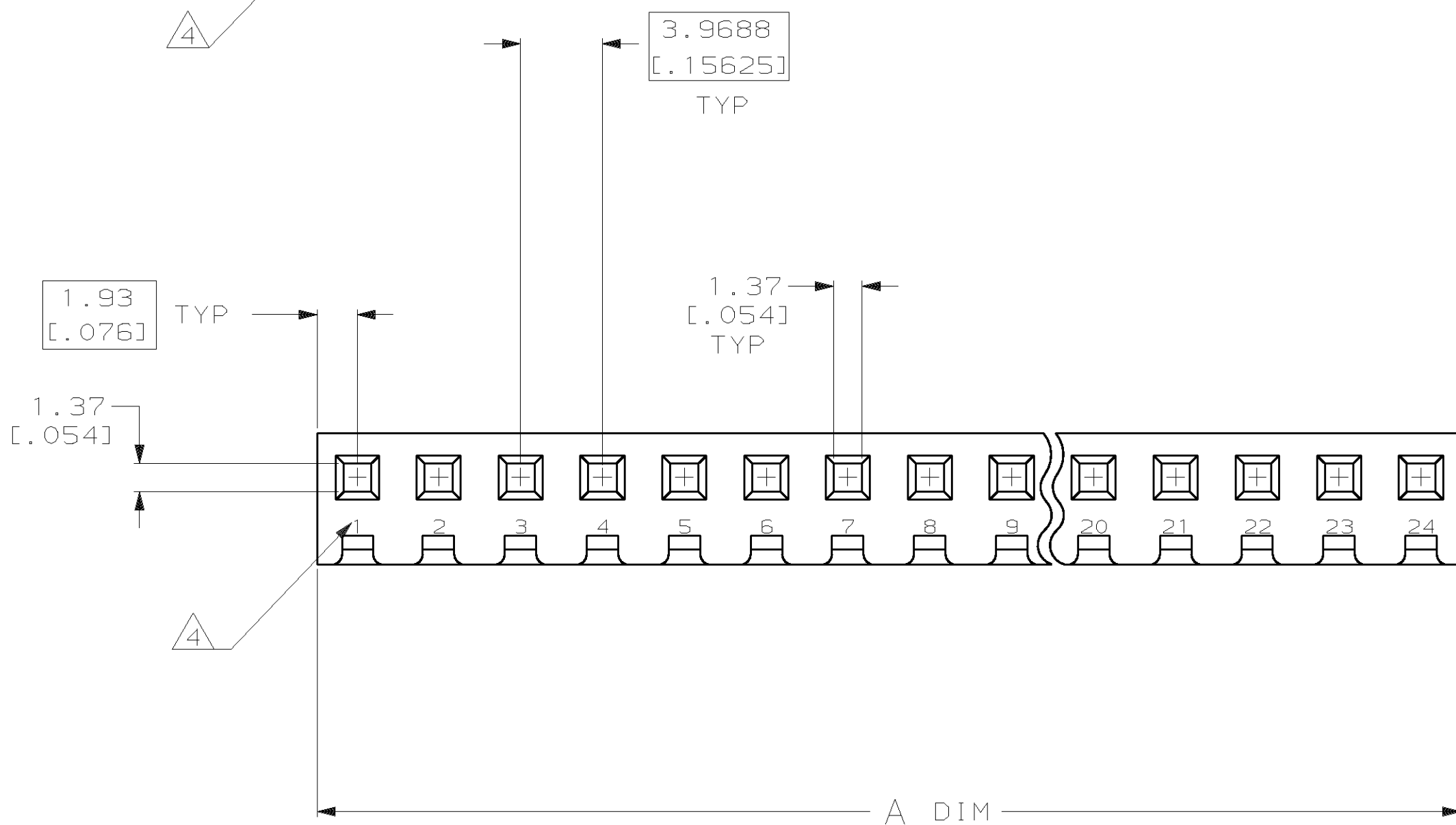

3-DIMENSIONAL MODEL NTS

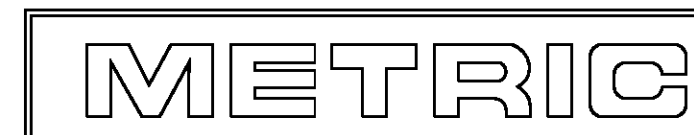

95.15	[3.746]	24	2-640251-4
91.19	[3.590]	23	2-640251-3
87.20	[3.433]	22	2-640251-2
83.24	[3.277]	21	2-640251-1
79.27	[3.121]	20	2-640251-0
75.31	[2.965]	19	1-640251-9
71.32	[2.808]	18	1-640251-8
67.36	[2.652]	17	1-640251-7
63.40	[2.496]	16	1-640251-6
59.44	[2.340]	15	1-640251-5
55.45	[2.183]	14	1-640251-4
51.49	[2.027]	13	1-640251-3
47.52	[1.871]	12	1-640251-2
43.56	[1.715]	11	1-640251-1
39.57	[1.558]	10	1-640251-0
35.61	[1.402]	9	640251-9
31.65	[1.246]	8	640251-8
27.69	[1.090]	7	640251-7
23.70	[.933]	6	640251-6
19.74	[.777]	5	640251-5
15.77	[.621]	4	640251-4
11.81	[.465]	3	640251-3
7.82	[.308]	2	640251-2
3.86	[.152]	1	640251-1

DO NOT SCALE PRINT. UNLESS SPECIFIED DIMENSIONS IN mm [INCHES] TOLERANCES ON:		DR 6-11-92 B. LEWIS		AMP Incorporated Harrisburg, PA 17105-3508	
2 PLC DEC ± -		CHK 6-11-92 R. SWING			
3 PLC DEC ± 0.13 [.005]		APPD 7-15-92 E. BEILES		NAME	
ANGLES ± -		MATERIAL		HOUSING WITHOUT LOCKING RAMP, SL-156	
NYLON, UL 94V-0 NATURAL		PRODUCT SPEC		SIZE	
FINISH		APPLICATION SPEC		D 00779	
-		WEIGHT		CAGE CODE	
				00779	
				DRAWING NO	
				640251	
				SCALE	
				4:1	
				SHEET	
				1 OF 1	

**NOTE**

All numerical values are in metric units [with U.S. customary units in brackets]. Dimensions are in millimeters [and inches]. Unless otherwise specified, dimensions have a tolerance of  $\pm 0.13$  [.005] and angles have a tolerance of  $\pm 2^\circ$ . Figures and illustrations are for identification only and are not drawn to scale.

**1. INTRODUCTION**

This specification covers the requirements for application of AMP\* SL 156 Contacts and Housings. These requirements are applicable to hand or automatic machine crimping tools. The contact housings are used for wire-to-board interconnection and mate with 1.14 [.045] square or round post headers or staked posts on 3.96 [.156] centers.

The wire-to-board connector is a two-piece connector system with the wire crimped to the contact, then inserted into the housing. This product mates with the MTA-156 flat, polarized and friction lock header, or staked posts.

When corresponding with AMP personnel, use the terminology provided in this specification to facilitate your inquiry for information. Basic terms and features of the connectors and contacts are provided in Figure 1.

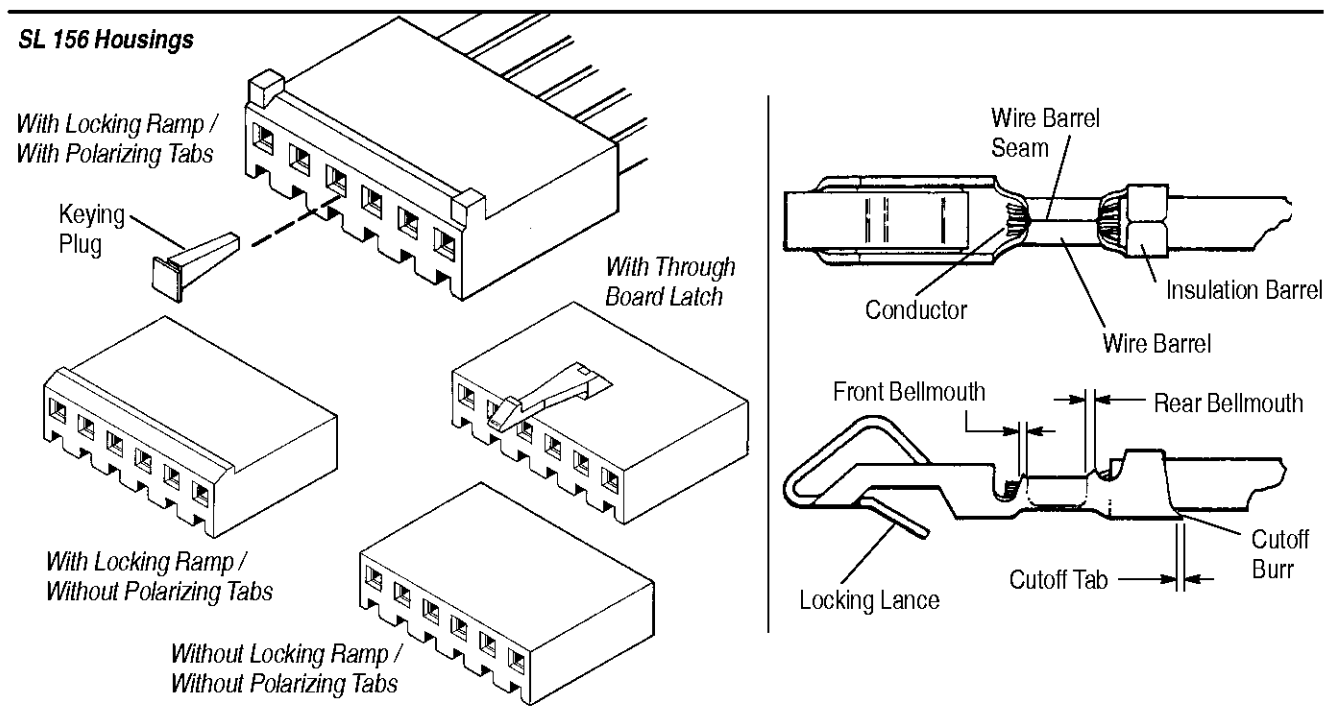

Figure 1

**2. REFERENCE MATERIALS****2.1. Revision Summary**

This paragraph is reserved for a revision summary covering the most recent additions and changes made to this specification which include the following:

Per EC 0990-0973-96:

- Revised table in Figure 2
- Changed wire barrel flash dimension in Paragraph 3.3
- Added new paragraphs, Contact Insertion
- Added UL and CSA numbers to Section 4
- Revised Section 5 and added additional illustrations to Figure 7.

## 2.2. Customer Assistance

Reference Part Number 640252, 640250 and Product Code 1385 are representative numbers that identify the SL 156 Contact and Housing product line. These numbers are used in the AMP network of customer service to access tooling and product application information. This service is provided by your local AMP representative (Field Sales Engineer, Field Application Engineer, etc.) or, after purchase, by calling the Tooling Assistance Center number at the bottom of page 1.

## 2.3. Drawings

Customer Drawings for specific products are available from the responsible AMP Engineering department via the service network. The information contained in the Customer Drawings takes priority if there is a conflict with this specification or with any other technical documentation supplied by AMP Incorporated.

## 2.4. Specifications

AMP Product Specification 108-1049 provides applicable performance requirements for the SL 156 Connector system.

## 2.5. Instructional Material

The following AMP Instruction Sheets (408-Series) and AMP Customer Manuals (409-Series) are supporting documents available to assist with product application or tool setup operation.

408-4228	PRO-CRIMPER* II Hand Tool Assembly 58614-1 with Die Assembly 58614-2
408-9930	PRO-CRIMPER II Hand Crimping Tool Frame Assembly 354940-1
408-8040	AMP Heavy Duty Miniature Quick-Change Applicators (Side Feed)
408-7332	Hand Crimping Tools 90123-2, 90123-5, and 90124-2
409-5842	AMP-O-ELECTRIC* Model "G" Terminating Machine 354500-[ ]
409-5855	AMP-O-MATIC* Side Feed Stripper Crimper Model II Machine 854040-3, and -4
409-5878	AMPOMATOR* CLS III "G" Lead Making Machine 356500-[ ]

## 3. PLUG REQUIREMENTS

### 3.1. Wire Preparation

#### A. Wire Selection

The contacts will accept stranded copper wire ranging in size from 18 to 24 AWG. Special contact 641550 will accept 24-30 AWG wire. Wire insulation diameter shall be a minimum dimension of 1.09 [.043] and a maximum dimension of 2.79 [.110].

#### B. Wire Preparation

Wire strip length shall be  $3.96 \pm 0.38$  [.156  $\pm$  .015]. Reasonable care shall be taken during the stripping operation to ensure the conductor is not nicked, scraped, or cut.

### 3.2. Crimped Contacts

The contacts shall be crimped in accordance with the instructional material packaged with the tooling; refer to the table in Figure 2.

#### A. Carrier Cutoff Tab

Cutoff tab shall not exceed 0.38 [.015].

#### B. Carrier Cutoff burr

Cutoff burr shall not exceed 0.08 [.003].

#### C. Wire Barrel Crimp

Wire barrel crimp width and height shall be as specified in Figure 2.

#### D. Wire Barrel Flash

Wire Barrel flash shall not exceed 0.25 [.010]

#### E. Wire Barrel Seam

The wire barrel seam shall be closed adequately to confine all strands of wire. There shall be no loose wire strands. Wire strands shall not be embedded in the seam of the wire barrel.

**F. Front And Rear Bell Mouth**

Front bellmouth shall be 0.25 [.010] maximum; rear bellmouth shall be 0.25 to 0.50 [.010 to .020].

**G. Conductor Location**

The end of the wire shall be flush with the front end of the wire barrel or extend 0.79 [.031] maximum after crimping. See Figure 2.

Both insulation and conductor shall be visible between the insulation barrel and wire barrel. Care shall be taken not to allow insulation to be crimped in the wire barrel.

**H. Insulation Barrel**

Insulation barrel crimp width shall be as specified in Figure 2.

Reasonable care shall be taken not cut or break the insulation during the crimping operation.

**I. Locking Lance**

Locking lance shall not be deformed.

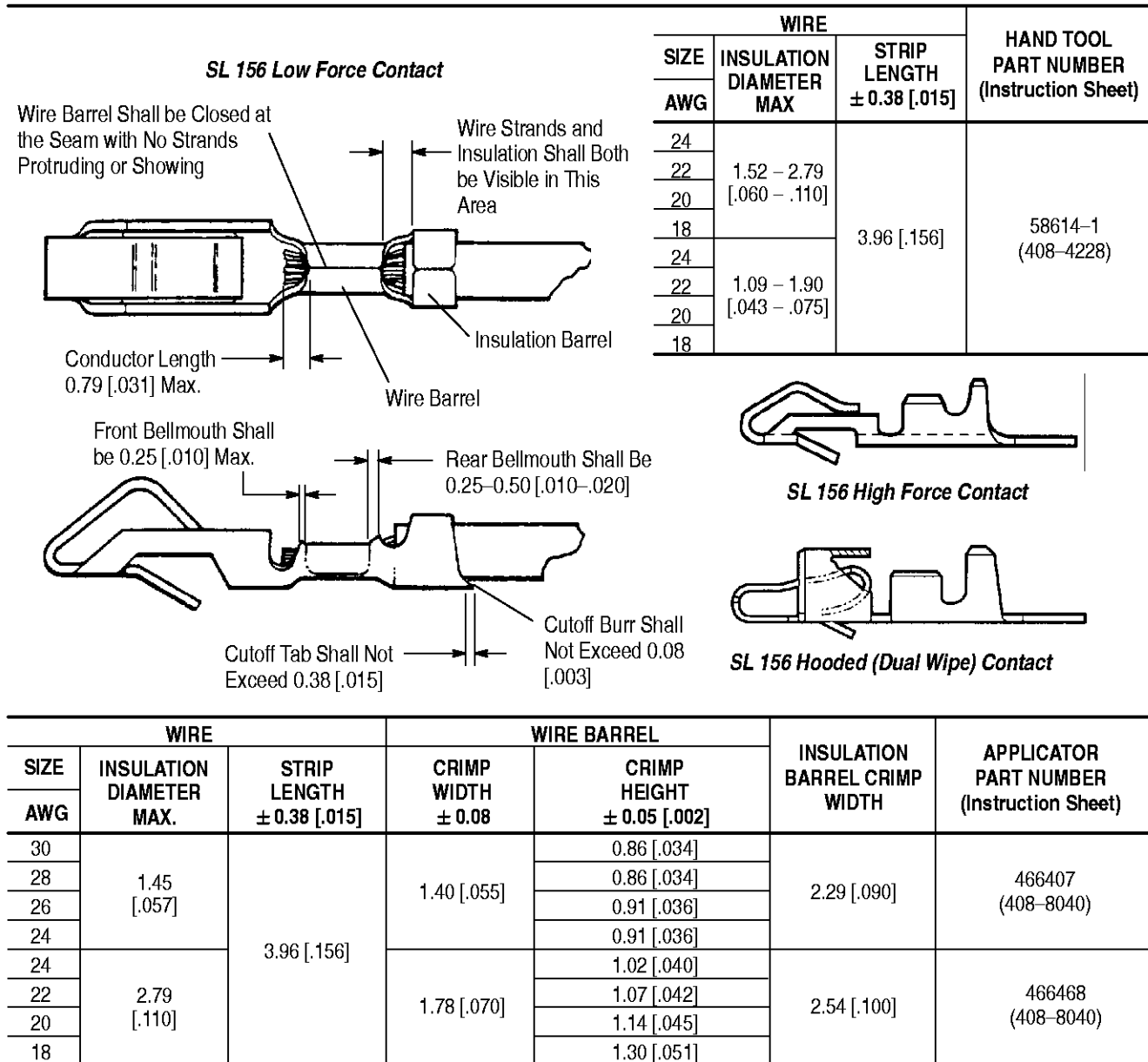

Figure 2

**3.3. Alignment**

1. The contact, including the cutoff tab and burr, shall not be bent above or below the datum line more than the amount shown in Figure 3.
2. The side-to-side bending of the contact shall not exceed the limit specified in Figure 3.
3. There shall be no twist or roll in the crimped portion that will impair usage of the contact.

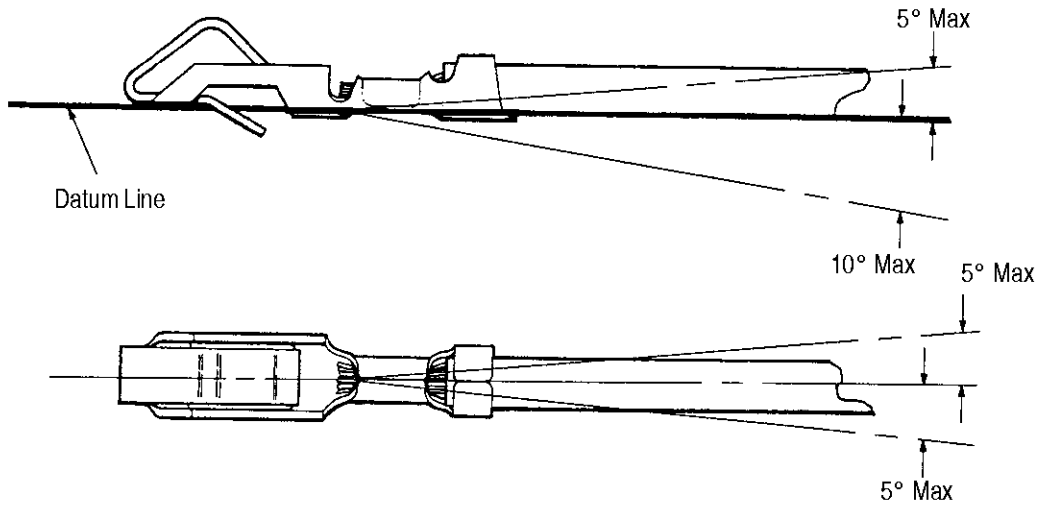

Figure 3

**3.4. Assembly Procedures**

**A. Contact Insertion**

Select the appropriate contact cavities. Grasp terminated SL156 contact directly behind the insulation barrel and push the contact straight into the contact cavity, then pull back lightly to ensure the locking lance has engaged. See Figure 4. Follow this procedure for remaining contacts.

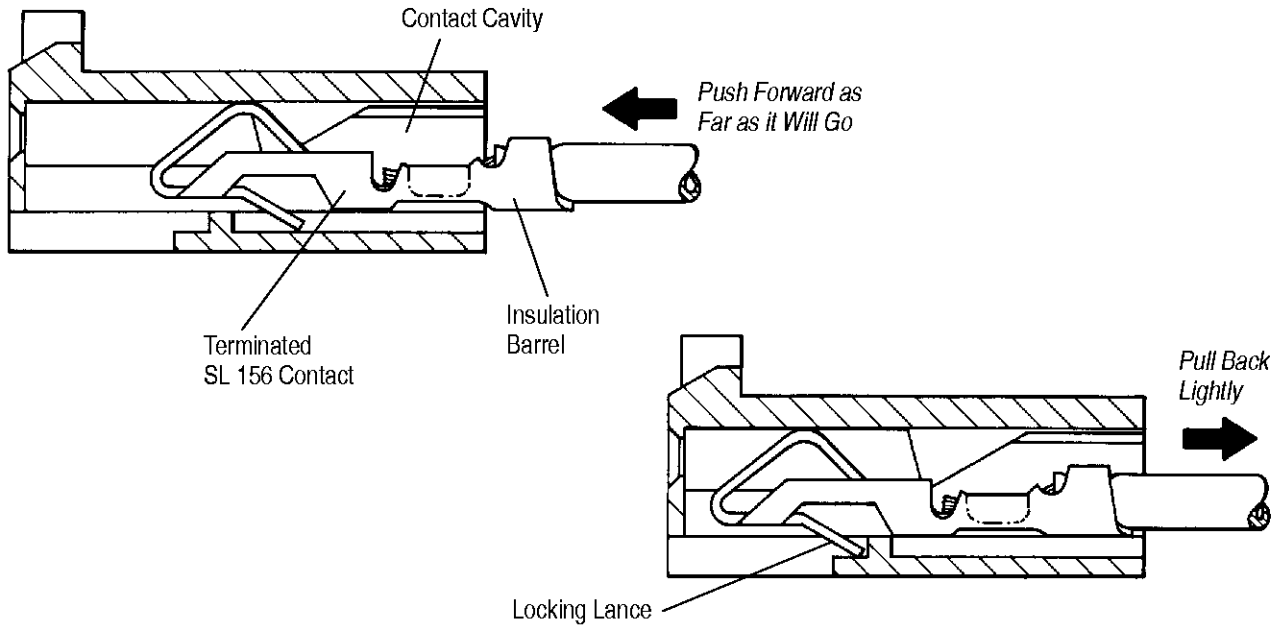
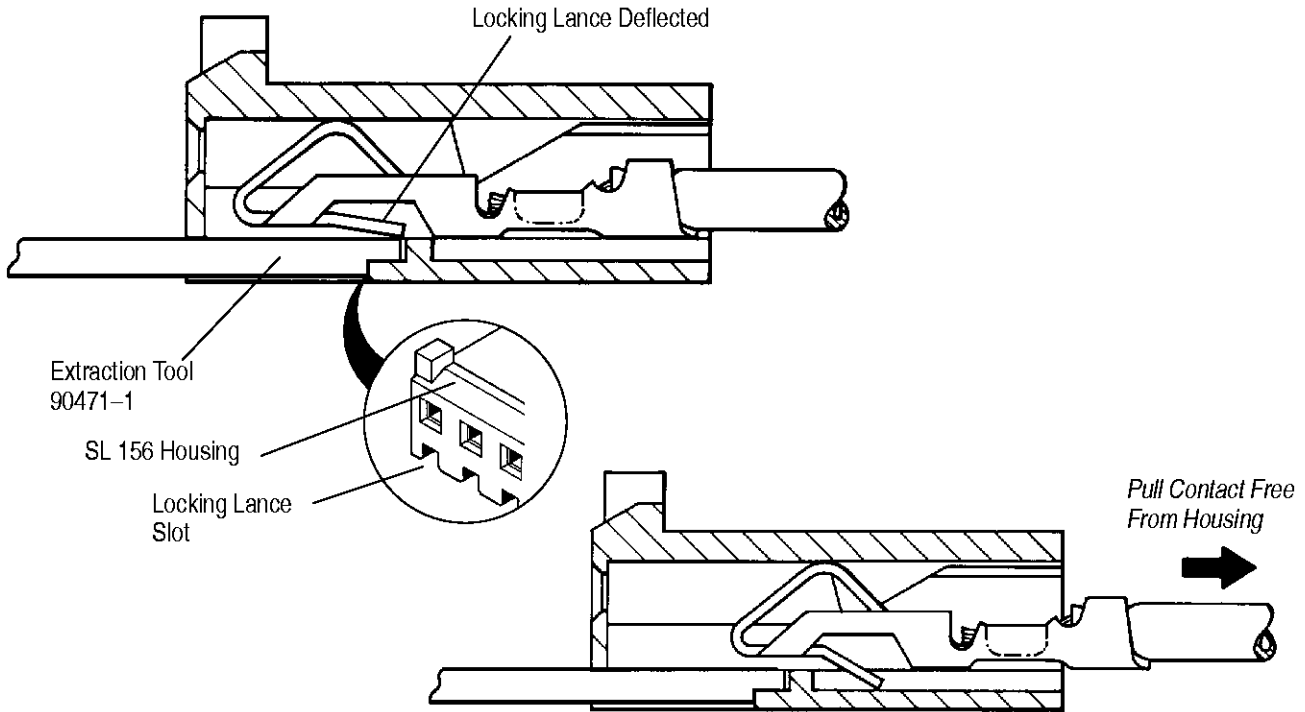

Figure 4

**B. Contact Extraction**

Insert contact extraction tool 90471-1 into the selected locking lance slot until it bottoms as shown in Figure 5. Insertion of the extraction tool will deflect the locking lance. Pull the terminated wire free from the housing.

*Figure 5***3.5. Polarization**

Post (s) from the header assemblies can be omitted for keying purposes. Identify the desired post to be omitted and insert keying plug 640254-1 into the corresponding contact cavity of the SL 156 connector housing. This procedure will ensure polarization as shown in Figure 6.

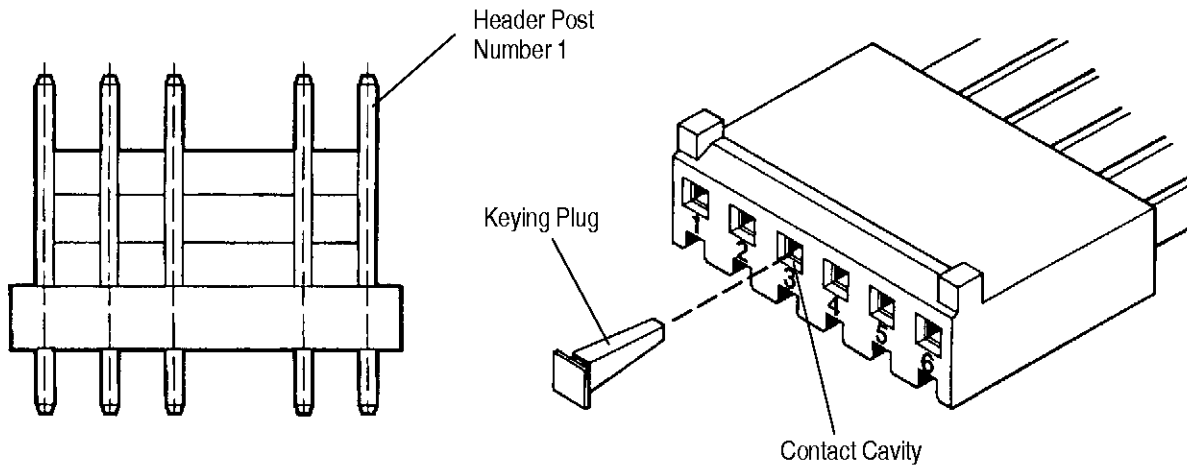
*Figure 6*

**4. QUALIFICATIONS****4.1. Underwriters Laboratories Inc. (UL)**

SL 156 Connectors are listed under UL File Number E28476.

**4.2. Canadian Standards (CSA)**

SL 156 Connectors are certified under CSA File number LR7189.

**5. TOOLING** (Figure 7)

For contact crimping, refer to the tables in Figure 2 for the appropriate hand tools and applicators. The instruction sheets, applicator instruction sheets, and customer manuals are referenced in Paragraph 2.5, Instructional Material.

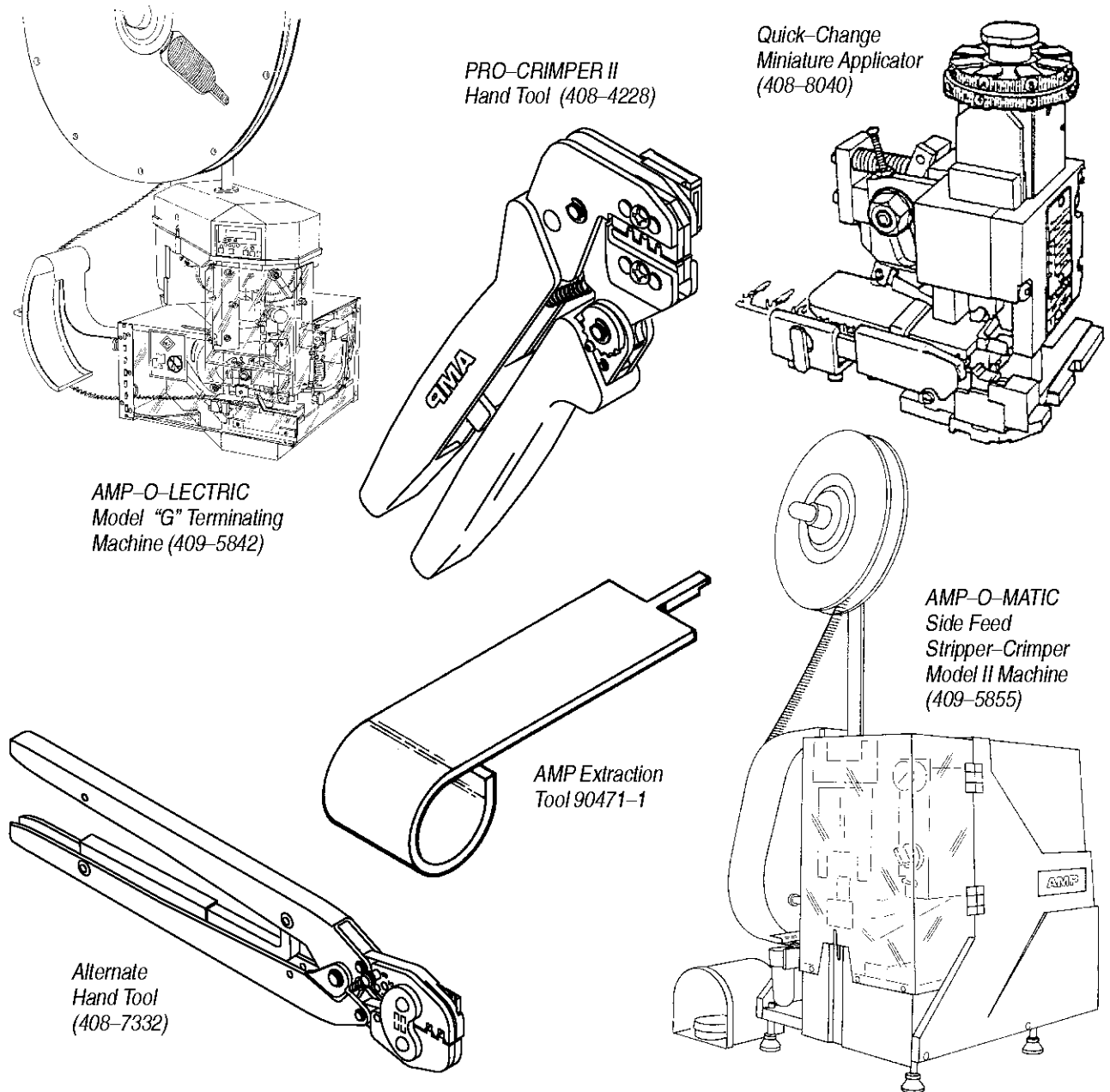
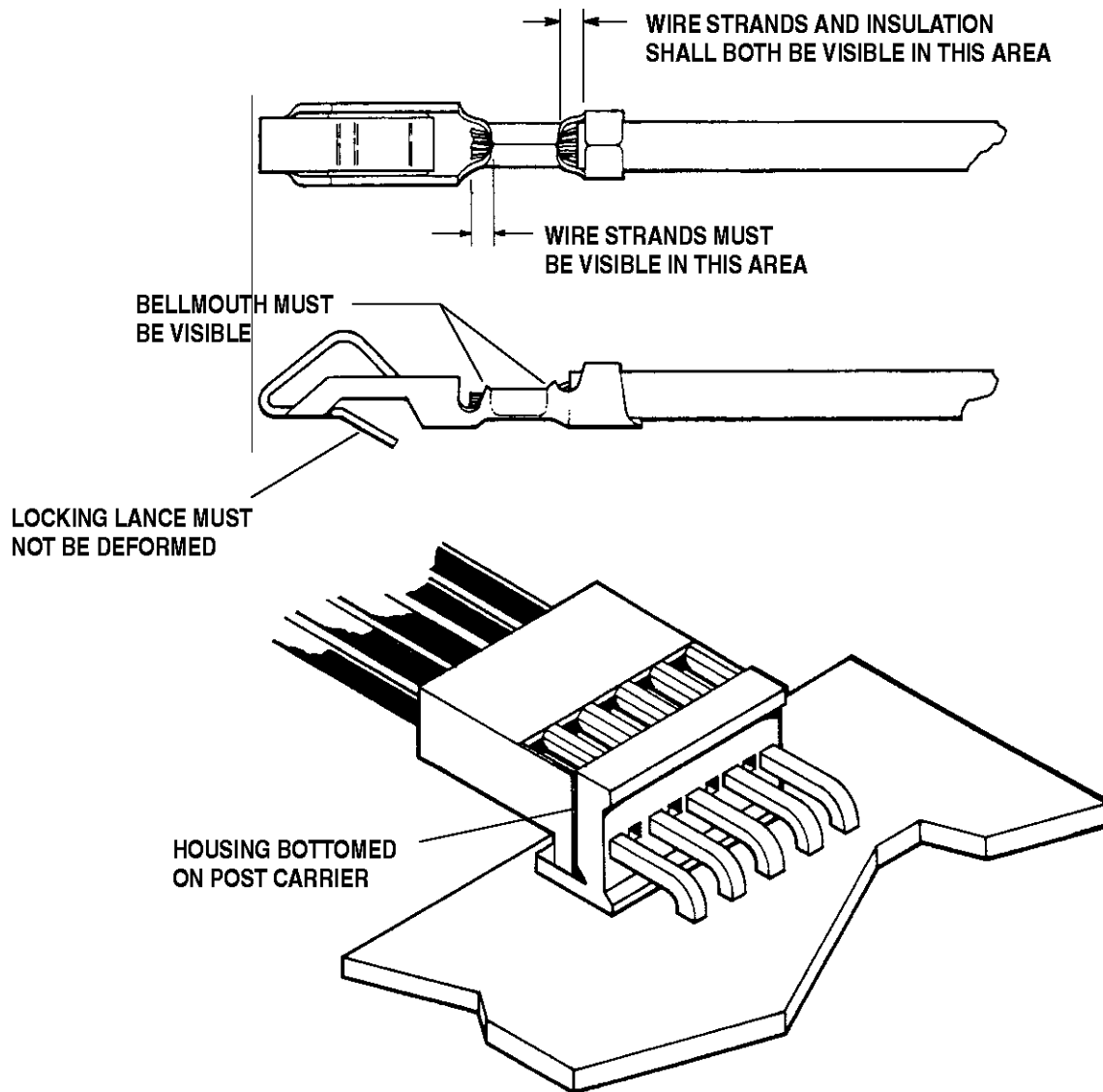

Figure 7



**6. VISUAL AID** (Figure 8)

The following illustrations are to be used by production personnel to ensure properly applied product. The views suggest requirements for correct applications. Applications considered visually incorrect should be inspected using the information in the main body of this document.

**FIGURE 8. VISUAL AID**



### 3.3. Ratings

- A. Current/Voltage: 250 vac at 6.5 amperes maximum
- B. Operating temperature: -55° to 105° C

### 3.4. Performance and Test Description

Connector assemblies shall be designed to meet the electrical, mechanical and environmental performance requirements specified in Figure 1.

### 3.5. Test Requirements and Procedures Summary

Test Description	Requirement	Procedure
Examination of Product	Meets requirements of product drawing and AMP Spec 114-1021	Visual, dimensional and functional per applicable inspection plan.
<b>ELECTRICAL</b>		
Termination Resistance, Specified Current	Wire Test Resistance, Size, Current, milliohms <u>AWG ampere max initial</u> 24 1.5 4.00 22 3.0 3.75 20 4.5 3.50 18 6.0 3.00	Measure potential drop of connector assembly mated with .045 posts on printed circuit board, see Figure 4; AMP Spec 109-25, calculate resistance.
Termination Resistance, Dry Circuit	3.00 milliohms maximum initial.	Subject mated contacts assembled in housing to 50 mv open circuit at 100 ma maximum, see Figure 4; AMP Spec 109-6, cond A.
Dielectric Withstanding Voltage	2.0 kvac; 1 minute dielectric withstanding voltage.	Test between adjacent circuits of unmated connector assembly; AMP Spec 109-29-1.
Insulation Resistance	1000 megohms minimum initial, 100 megohms minimum final.	Test between adjacent circuits of unmated connector assembly; AMP Spec 109-28-4.
Temperature Rise vs Current (b)	Temperature rise, see Figure 3; termination resistance.	T-rise at rated current; AMP Spec 109-45.

### MECHANICAL

Figure 1 (cont)

<b>AMP</b>		AMP INCORPORATED Harrisburg, Pa.		SHEET <u>2 OF 6</u>	
LOC <b>B</b>	<b>A</b>	NO <b>108-1049</b>	REV <b>C</b>		
NAME CONNECTOR, SL 156					

Test Description	Requirement	Procedure
Mating Force	Force, pounds Contact maximum <u>Type</u> <u>.045 Sq</u> <u>.045 Rd</u> High Force 4.2 1.75 Low Force 1.5 1.25	Measure force necessary to mate connector assembly with .045 square and round posts mounted on printed circuit board; AMP Spec 109-42, calculate force per contact.
Unmating Force	Force, pounds Contact minimum <u>Type</u> <u>.045 Sq</u> <u>.045 Rd</u> High Force 1.5 0.50 Low Force 0.25 0.25	Measure force necessary to unmate connector assembly with .045 square and round posts mounted on printed circuit board; AMP Spec 109-42, calculate force per contact.
Contact Retention	10 pounds minimum.	Apply axial load to crimped contacts by gripping wire; AMP Spec 109-30.
Durability	Mating and unmating force; 3.50 milliohms maximum termination resistance, dry circuit.	Mate and unmate connector assemblies for 25 cycles with .045 post and printed circuit board on fixture and manually mate; AMP Spec 109-27.
Crimp Tensile	Wire Size, Crimp Tensile, <u>AWG</u> <u>pounds minimum</u> 24 10 22 15 20 25 18 35	Determine crimp tensile at a rate of 1 inch/minute; AMP Spec 109-16.

**ENVIRONMENTAL**

Thermal Shock (a)	Dielectric withstanding voltage; 4.50 milliohms maximum termination resistance, dry circuit.	Subject mated connectors to 25 cycles between -55° and 85°C; AMP Spec 109-22.
-------------------	--	---

- (a) Connector assemblies shall remain mated and shall show no evidence of cracking or chipping.
- (b) Maximum rated current that can be carried by this product is limited by maximum operating temperature of housings, which is 105°C, and temperature rise of contacts, which is 30°C. Variables which shall be considered for each application are: wire size, connector size, contact material, ambient temperature, and printed circuit board design.

Figure 1 (end)

SHEET		<b>AMP</b>		AMP INCORPORATED Harrisburg, Pa.	
3 OF 6		LOC	NO	REV	
		B	A	108-1049 C	
NAME					
CONNECTOR, SL 156					

### 3.6. Connector Tests and Sequences

Test or Examination	Test Group (a)					
	1	2	3	4	5	6
	Test Sequence (b)					
Examination of Product	1					
Termination Resistance, Specified Current			1			
Termination Resistance, Dry Circuit		3,5		2,4		
Dielectric Withstanding Voltage		1,6				
Insulation Resistance		2,7				
Temperature Rise vs Current			2			
Mating Force				1		
Unmating Force				5		
Contact Retention						1
Durability				3		
Crimp Tensile					1	
Thermal Shock		4				

(a) See Para 4.1.A.

(b) Numbers indicate sequence in which tests are performed.

Figure 2

## 4. QUALITY ASSURANCE PROVISIONS

### 4.1. Qualification Testing

#### A. Sample Selection

Connector housings and contacts shall be prepared in accordance with applicable Instruction Sheets. They shall be selected at random from current production. Test group 1 shall consist of 1 housing of each size, and 5 contacts all representative of the entire lot being tested. Test group 2 through 4 shall consist of 6 connector assemblies per group. The housings and wire sizes shall be chosen randomly to cover the range of the product line. Group 5 samples shall consist of 15 contacts per wire size. Group 6 samples shall consist of 15 contacts crimped on #18 AWG wire and tested with appropriate random housings. All contacts shall be crimped to appropriate PN 103501 and 103502 tin plated test conductors in accordance with AMP Specification 114-1021. For tests which require connector mating, .045 square or .045 round posts shall be used.

<b>AMP</b>		AMP INCORPORATED Harrisburg, Pa.		<b>SHEET</b>	
				<u>4</u> OF <u>6</u>	
LOC <b>B</b>	<b>A</b>	NO <b>108-1049</b>	REV <b>C</b>		
NAME <b>CONNECTOR, SL 156</b>					

B. Test Sequence

Qualification inspection shall be verified by testing samples as specified in Figure 2.

C. Acceptance

- (1) Requirements put on test samples, as indicated in the requirements portion of Figure 1, exist as either the upper or lower statistical tolerance limit (95% confidence, 99% reliability). All samples tested in accordance with this specification shall meet the stated tolerance limit.
- (2) Failures attributed to equipment, test setup, or operator deficiencies shall not disqualify the product. When product failure occurs, corrective action shall be taken and samples resubmitted for qualification.

4.2. Quality Conformance Inspection

The applicable AMP inspection plan will specify the sampling acceptable quality level to be used. Dimensional and functional requirements shall be in accordance with the applicable product drawing and this specification.

4.3. Certification

This product has been Recognized under the Component Recognition Program of Underwriters Laboratories Inc., Electrical File Number E-28476 and certified by Canadian Standards Association File Number LR-16455.

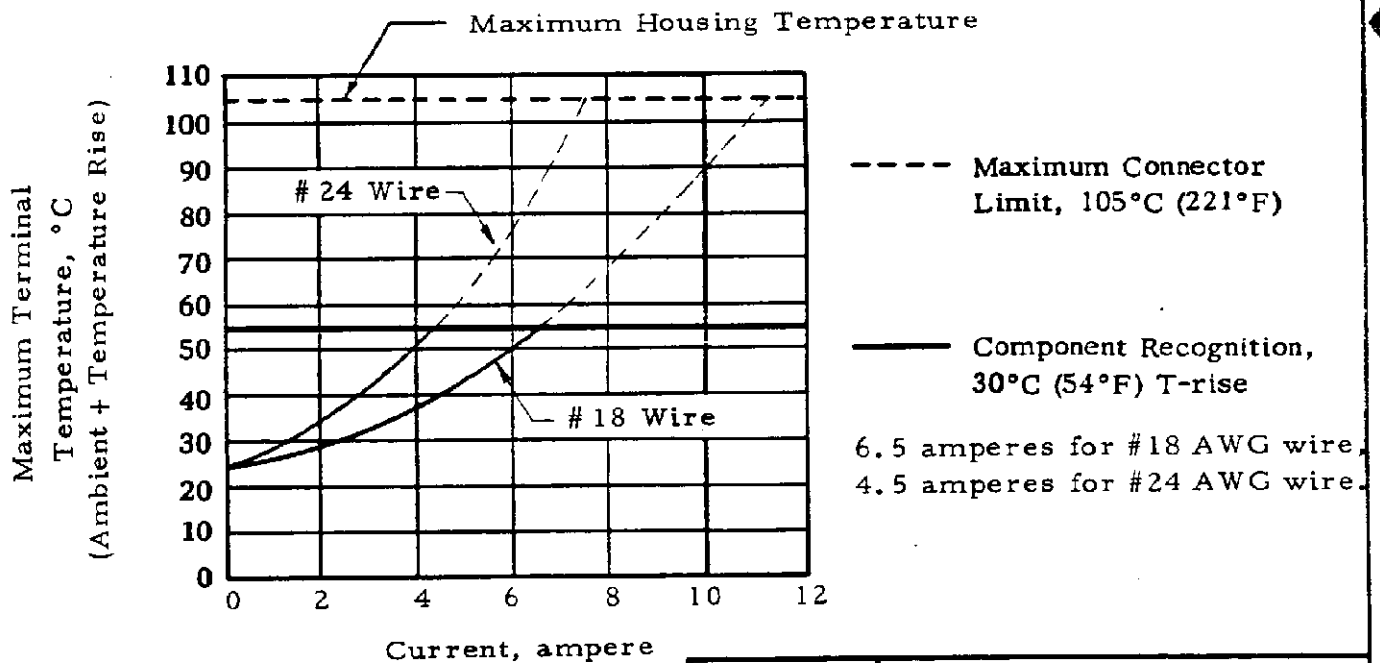
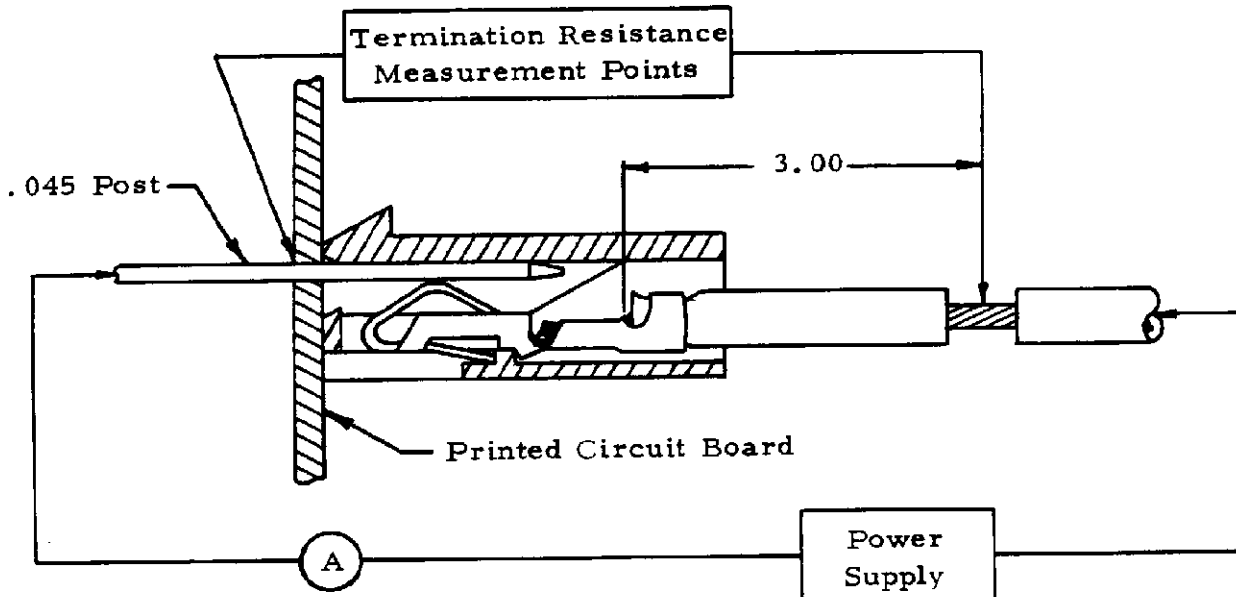

Figure 3

Terminal Temperature vs Current/Circuit,  
5 Position Housing

SHEET		<b>AMP</b>		AMP INCORPORATED Harrisburg, Pa.	
5 OF 6		LOC	NO	REV	
		B	A	108-1049 C	
NAME					
CONNECTOR, SL 156					



- Notes:
1. A 1 ft min length of continuous lead for heat dissipation.
  2. Termination resistance equals millivolts divided by test current less resistance of 3 inches of wire.
  3. Printed circuit board test board is tin plated 1 ounce copper.

Figure 4

Termination Resistance Measurement Points

<b>AMP</b>		AMP INCORPORATED Harrisburg, Pa.		SHEET <u>6</u> OF <u>6</u>	
LOC <b>B</b>	<b>A</b>	NO <b>108-1049</b>	REV <b>C</b>		
NAME CONNECTOR, SL 156					