

640389-8 Product Details

[Share](#) [Print](#) [Email](#)



640389-8

TE Internal Number: 640389-8

 Active

[View 3D PDF](#)

MTA, CST-100 II, MT-6 and SL Connectors and Headers

 Always EU RoHS/ELV Compliant
(Statement of Compliance)

Product Highlights:

- MTA-156 Product Line
- MTA Series
- Wire-to-Board
- Applies To Printed Circuit Board
- Connector

[View all Features](#)

Quick Links

- ▶ [Pricing & Availability](#)
- ▶ [Search for Tooling](#)
- ▶ [View Mating Products \(94\)](#)
- ▶ [Product Feature Selector](#)
- ▶ [Contact Us About This Product](#)

[Add to My Part List](#) [Request Sample](#) [Find Similar Products](#)
[Buy Product](#)

Documentation & Additional Information

Product Drawings:

- [MTA-156 HEADER ASSEMBLY, FRICTION LOCK, RIGHT ANGLE,...](#) (PDF, English)

Catalog Pages/Data Sheets:

- [MTA, CST-100 II, SL-156 and AMP Economy Power \(EP\) C...](#) (PDF, English)

Product Specifications:

- None Available

Application Specifications:

- None Available

Instruction Sheets:

- None Available

CAD Files: (CAD Format & Compression Information)

- [2D Drawing](#) (DXF, Version AG)
- [3D Model](#) (IGES, Version AG)
- [3D Model](#) (STEP, Version AG)

[List all Documents](#)

Additional Information:

- [Product Information](#)
- [Product Line Information](#)

Related Products:

- [Tooling](#)
- [Mating Products \(94\)](#)

Product Features (Please use the Product Drawing for all design activity)

Product Type Features:

- [Product Line](#) = MTA-156
- Series = MTA
- Product Type = Connector
- Connector Type = Header
- Termination Method to Wire/Cable = Solder
- Post Size (mm [in]) = 1.14 [.045]
- Termination Method to PC Board = Through Hole - Solder
- [PCB Mounting Orientation](#) = Right Angle
- PCB Mount Retention = Without
- PCB Mount Alignment = Without
- [Right Angle Bending Side](#) = Front
- Strain Relief = Without
- Sealed = No
- UL File Number = E28476

Housing Features:

- Connector Style = Plug
- Centerline (mm [in]) = 3.96 [0.156]
- Housing Style = Friction Lock
- Housing Material = Polyester PBT GF
- Housing Color = Natural
- [Mating Alignment](#) = Without
- UL Flammability Rating = UL 94V-0

Configuration Features:

- [Number of Positions](#) = 8
- [Post Number\(s\) Omitted](#) = None
- [Backwall/Post Interruption\(s\)](#) = Without
- Number of Rows = 1

Industry Standards:

- CSA File Number = LR7189

Mechanical Attachment:

- Contact Retention = Without
- Mating Retention Type = Friction Lock
- [Panel Mount Retention](#) = Without

Electrical Characteristics:

- Contact - Rated Current (A) = 7
- Operating Voltage Reference = AC
- Operating Voltage (VAC) = 600

Termination Features:

- Tail Length (mm [in]) = 3.18 [0.125]

Dimensions:

- Mating Post Length (mm [in]) = 10.16 [0.400]
- PCB Thickness, Recommended (mm [in]) = 1.60 [0.063]

Body Features:

- Header Type = Unshrouded
- Mating Retention = With
- Underplate Material Thickness (μm [μin]) = 1.27 [50.000]
- Assembly Integration Feature = Without

Contact Features:

- Contact Type = Pin
- [Contact Shape](#) = Square
- [Contact Base Material](#) = Copper Alloy
- [Contact Plating, Mating Area, Material](#) = Tin
- Tail Plating Material = Tin
- Contact Style = Right-Angle
- Contact Layout = In-Line
- Multiple Contact Types = Without
- Contact Plating, Mating Area, Thickness (μm [μin]) = 2.54 [100]
- Tail Plating Thickness (μm [μin]) = 2.54 [100]
- Underplate Material = Nickel

- [RoHS/ELV Compliance](#) = RoHS compliant, ELV compliant
- [Lead Free Solder Processes](#) = Wave solder capable to 240°C, Wave solder capable to 260°C, Wave solder capable to 265°C
- RoHS/ELV Compliance History = Always was RoHS compliant
- Agency/Standard = CSA, UL
- UL Rating = Recognized
- CSA Rating = Certified

Environmental:

- Operating Temperature ($^{\circ}\text{C}$ [$^{\circ}\text{F}$]) = -55 - +105 [-67 - +221]

Conditions for Usage:

- [Applies To](#) = Printed Circuit Board
- For Use With = MTA .156 Connector Assembly or SL .156 Connector Assembly

Operation/Application:

- Application Use = Wire-to-Board

Packaging Features:

- Packaging Method = Package
- Packaging Quantity = 1

Other:

- Brand = AMP

Corporate Information

- [About TE](#)
- [Investors](#)
- [News Room](#)
- [Supplier Portal](#)
- [Careers](#)
- [Terms & Conditions](#)
- [Privacy Policy](#)

Quick Links

- [Distributor Inventory](#)
- [Product Cross Reference](#)
- [Documents & Drawings](#)
- [Product Compliance Support Center](#)
- [Site Map](#)

Customer Support

- [Email or Chat With Us](#)
- [Find a Phone Number](#)
- [Knowledge Base](#)
- [Manage Your Account](#)

Keep Me Informed



- 1 POST TO WITHSTAND 13 NEWTONS (3LBS.) MIN. AXIAL FORCE IN BOTH DIRECTIONS SHOWN WITHOUT DISLODGING.
- 2 TOLERANCES APPLY TO SOLDER SIDE OF BOARD.
- 3 MEASURED AT SURFACE -A-
- 4 PLASTIC FLASH PERMITTED IN THIS AREA.
- 5 PARTS COMPLY WITH AMP SOLDERABILITY SPEC. NO. 109-11-2.
- 6 ONE HOLE MAY BE UNDERSIZED (.065/.060 DIA.) FOR ASSEMBLY RETENTION DURING WAVE SOLDERING.
- 7 MATERIAL: HEADER-THERMOPLASTIC POLYESTER
GLASS-FILLED 94V-0 (NATURAL)
POST-COPPER ALLOY (TIN PLATED)
- 8 COORDINATE DIMENSION APPLIES FROM CENTER OF ACTUAL FEATURE.
- 9 PLASTIC BURRS CAUSED BY CUT-OFF TOOLING ARE PERMITTED WITHIN THE MAXIMUM TOLERANCE ENVELOPE.
- 10 POST TO BE MEASURED WHEN STRIP IS HELD FLAT.
- 11 POST MUST WITHSTAND TWO 90° BENDS AGAINST EXTRUSION WITHOUT BREAKING.
- 12 DIMENSION SHOULD BE .325-.400 WHEN MATING WITH A MTA 156 CONNECTOR ASSEMBLY OR .325-.345 WHEN MATING WITH A SL-156 CONNECTOR ASSEMBLY.
- 13 PIN BURR OF .005 MAX. VERTICAL AND .003 MAX. HORIZONTAL PERMITTED AT POST TIPS ON BOTH ENDS.

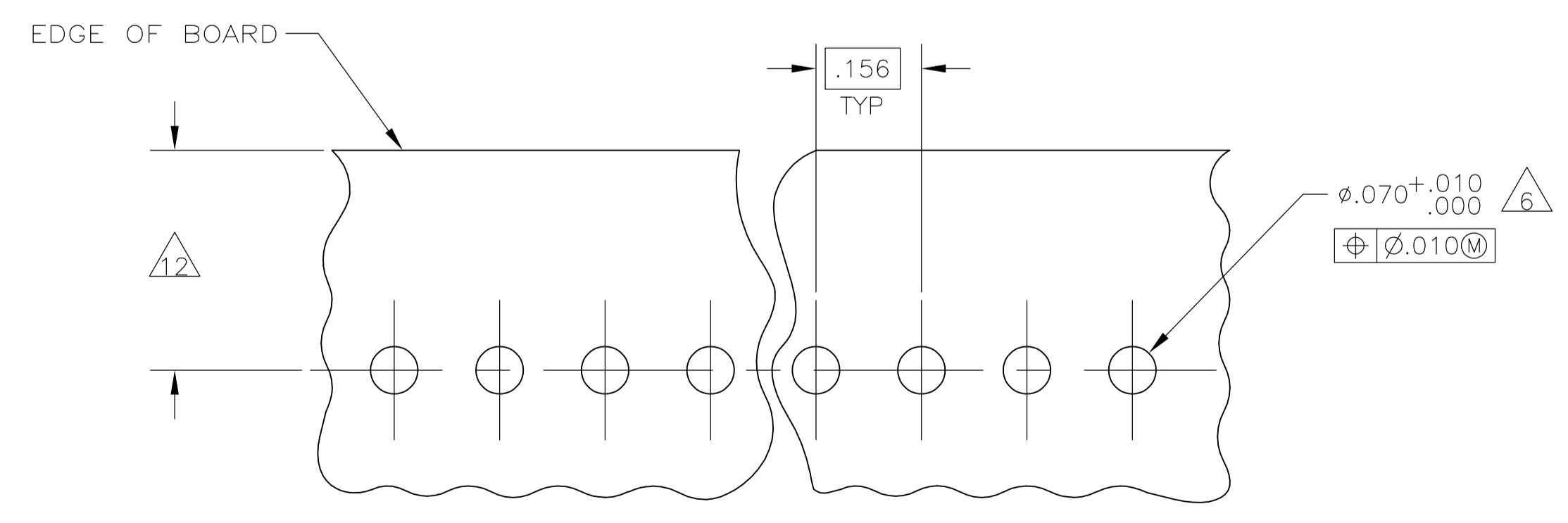
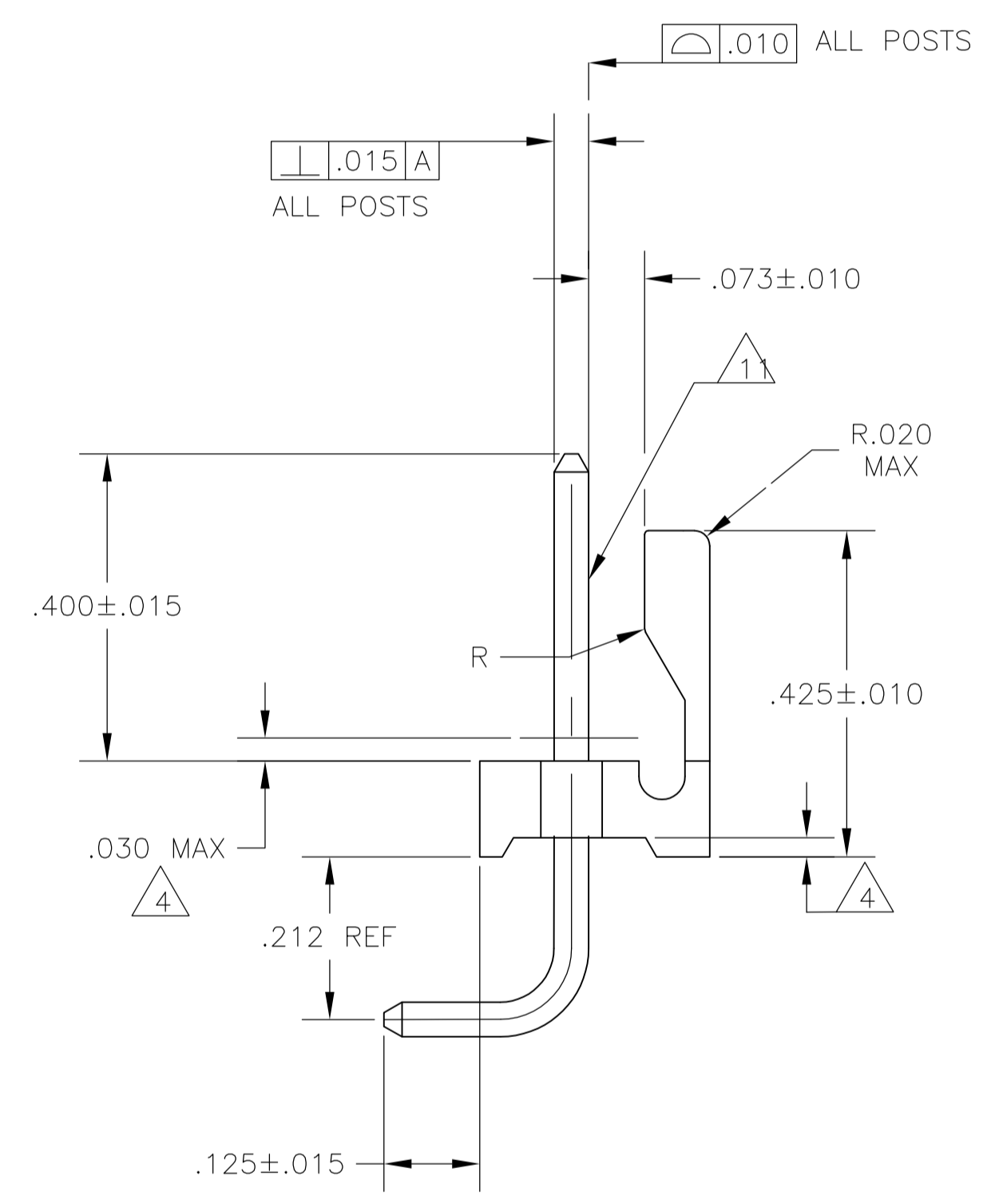
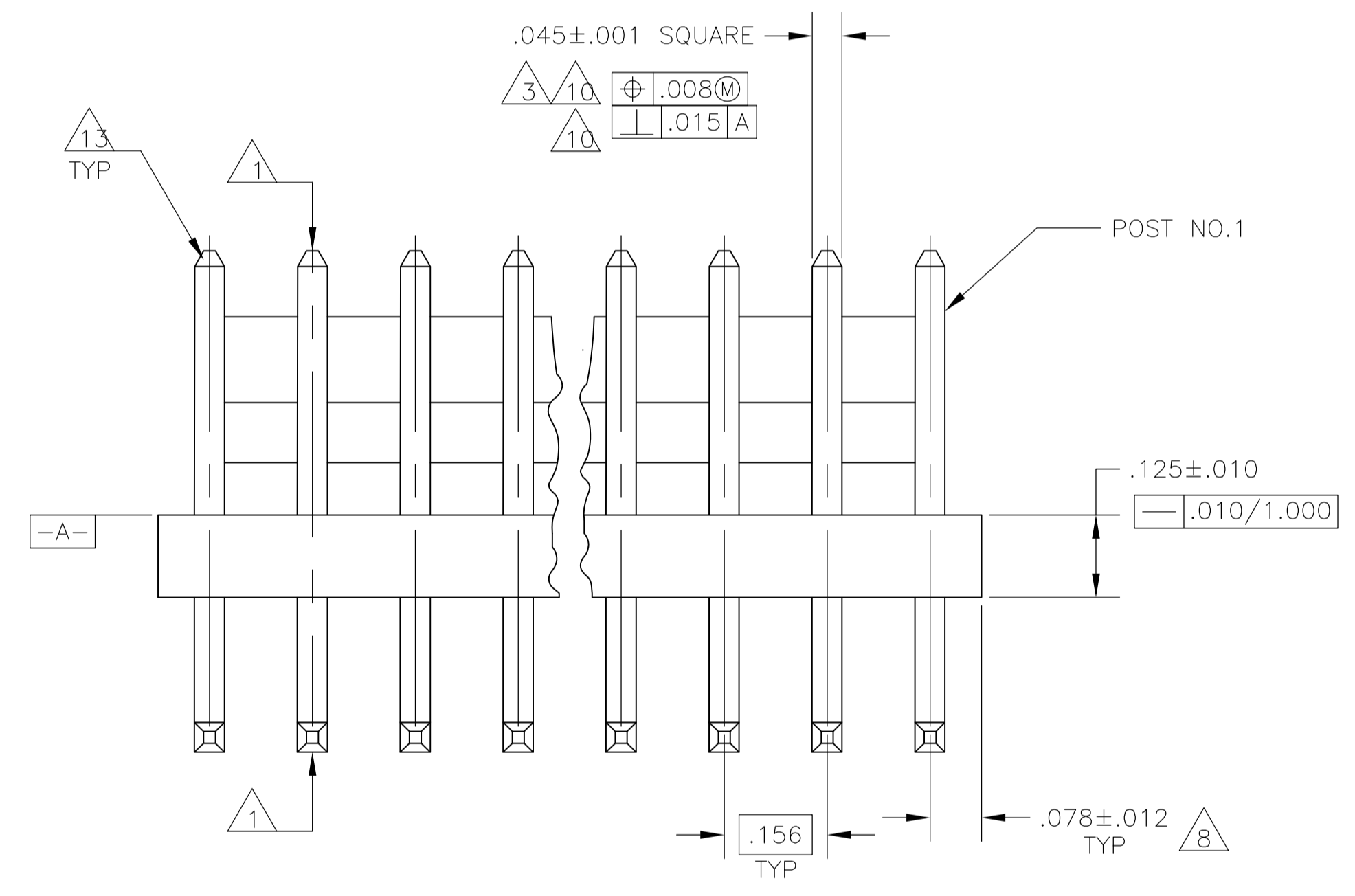
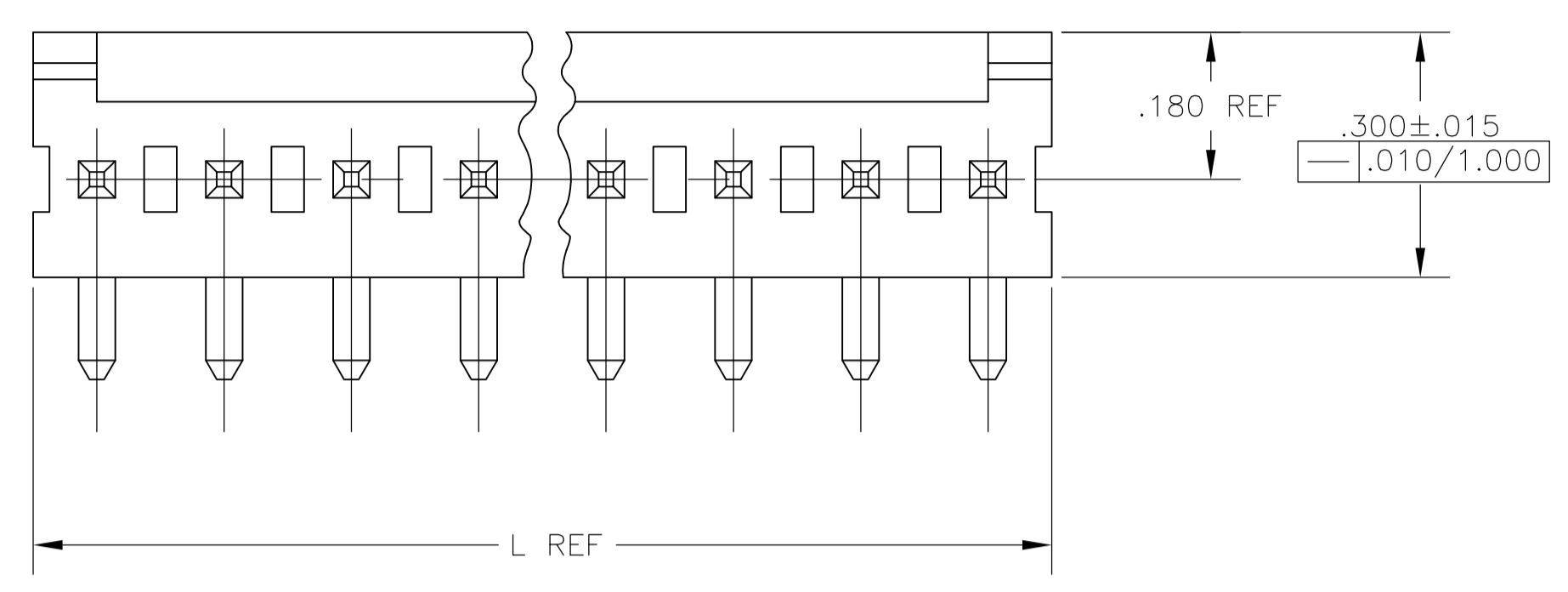

RECOMMENDED MOUNTING HOLE PATTERN FOR .063 THICK P.C. BOARD

.073	1.85		
.070	1.78		
.068	1.73		
.065	1.65	1.000	25.40
.063	1.60	.450	11.43
.060	1.52	.425	10.80
.045	1.14	.400	10.16
.030	0.76	.345	8.76
.015	0.38	.325	8.26
.012	0.30	.300	7.62
.010	0.25	.212	5.38
.008	0.20	.180	4.57
.005	0.13	.156	3.96
.003	0.08	.125	3.18
.001	0.03	.078	1.98
IN	MM	IN	MM

CONVERSION TABLE

95.10	3.744	24	2-640389-4
91.14	3.588	23	2-640389-3
87.17	3.432	22	2-640389-2
83.21	3.276	21	2-640389-1
79.25	3.120	20	2-640389-0
75.29	2.964	19	1-640389-9
71.32	2.808	18	1-640389-8
67.36	2.652	17	1-640389-7
63.40	2.496	16	1-640389-6
59.44	2.340	15	1-640389-5
55.47	2.184	14	1-640389-4
51.51	2.028	13	1-640389-3
47.55	1.872	12	1-640389-2
43.59	1.716	11	1-640389-1
39.62	1.560	10	1-640389-0
35.66	1.404	9	640389-9
31.70	1.248	8	640389-8
27.74	1.092	7	640389-7
23.77	.936	6	640389-6
19.81	.780	5	640389-5
15.85	.624	4	640389-4
11.89	.468	3	640389-3
7.92	.312	2	640389-2
MM	[IN]	NUMBER OF POSITIONS	PART NUMBER

THIS DRAWING IS A CONTROLLED DOCUMENT.

DIMENSIONS: INCHES	TOLERANCES UNLESS OTHERWISE SPECIFIED:	0 PLC ± -	1 PLC ± -	2 PLC ± -	3 PLC ± .005	4 PLC ± -	ANGLES ± -
--------------------	--	-----------	-----------	-----------	--------------	-----------	------------

MATERIAL	FINISH	WEIGHT	SIZE	CAGE CODE	DRAWING NO	RESTRICTED TO
			A1	00779	640389	

CUSTOMER DRAWING SCALE 5:1 SHEET 1 OF 1 REV AD1