

FIG. 2

- 1 POST TO WITHSTAND 13 NEWTONS (3LBS.) MIN. AXIAL FORCE IN BOTH DIRECTIONS SHOWN WITHOUT DISLODGING.
- 2 TOLERANCES APPLY TO SOLDER SIDE OF BOARD.
- 3 MEASURED AT SURFACE -A-
- 4 PLASTIC FLASH PERMITTED IN THIS AREA.
- 5 PARTS COMPLY WITH AMP SOLDERABILITY SPEC. NO. 109-11-2.
- 6 ONE HOLE MAY BE UNDERSIZED (.065/.060 DIA.) FOR ASSEMBLY RETENTION DURING WAVE SOLDERING.
- 7 MATERIAL: HEADER-THERMOPLASTIC POLYESTER GLASS-FILLED 94V-0(NATURAL) (FIG.2) POST-COPPER ALLOY (TIN PLATED)
- MATERIAL: HEADER-THERMOPLASTIC POLYESTER NON-FILLED 94V-0(NATURAL) (FIG.1) POST-COPPER ALLOY (TIN PLATED)
- 8 COORDINATE DIMENSION APPLIES FROM CENTER OF ACTUAL FEATURE.
- 9 PLASTIC BURRS CAUSED BY CUT-OFF TOOLING ARE PERMITTED WITHIN THE MAXIMUM TOLERANCE ENVELOPE.
- 10 POST TO BE MEASURED WHEN STRIP IS HELD FLAT.
- 11 POST MUST WITHSTAND TWO 90° BENDS AGAINST EXTRUSION WITHOUT BREAKING.
- 12 DIMENSION SHOULD BE .325-.400 WHEN MATING WITH A MTA 156 CONNECTOR ASSEMBLY OR .325-.345 WHEN MATING WITH A SL-156 CONNECTOR ASSEMBLY.
- 13 PIN BURR OF .005 MAX. VERTICAL AND .003 MAX. HORIZONTAL PERMITTED AT POST TIPS ON BOTH ENDS.

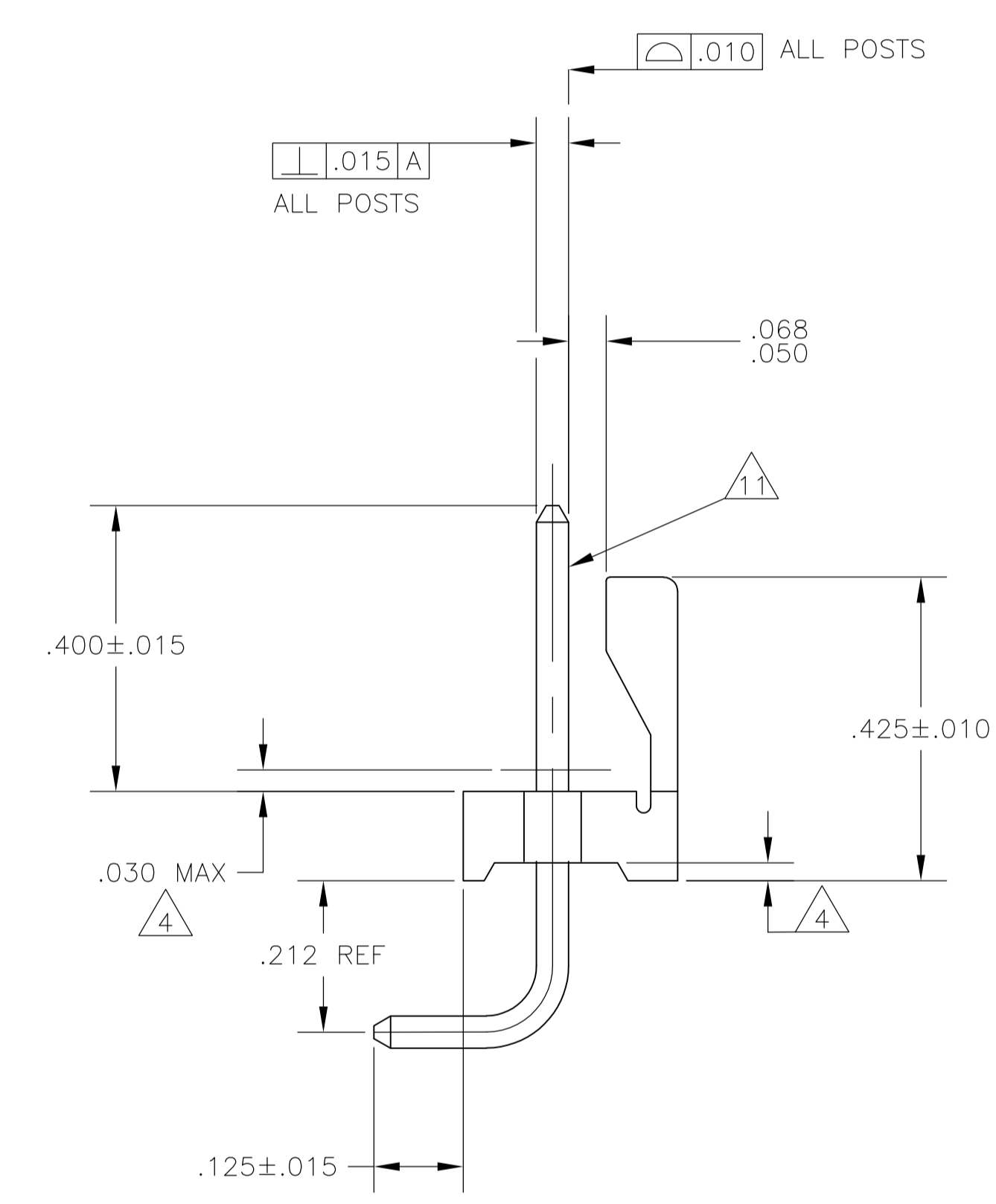
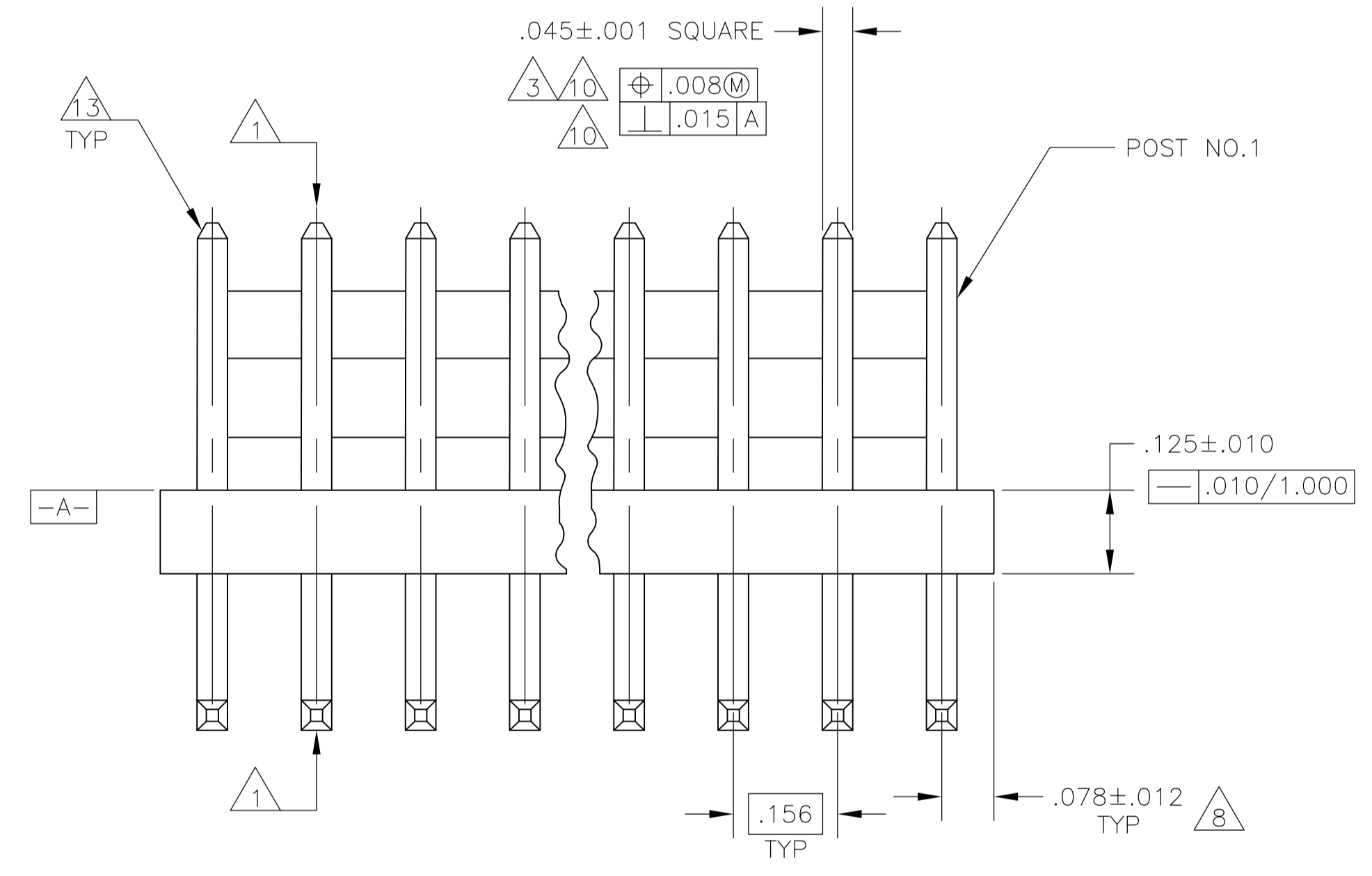
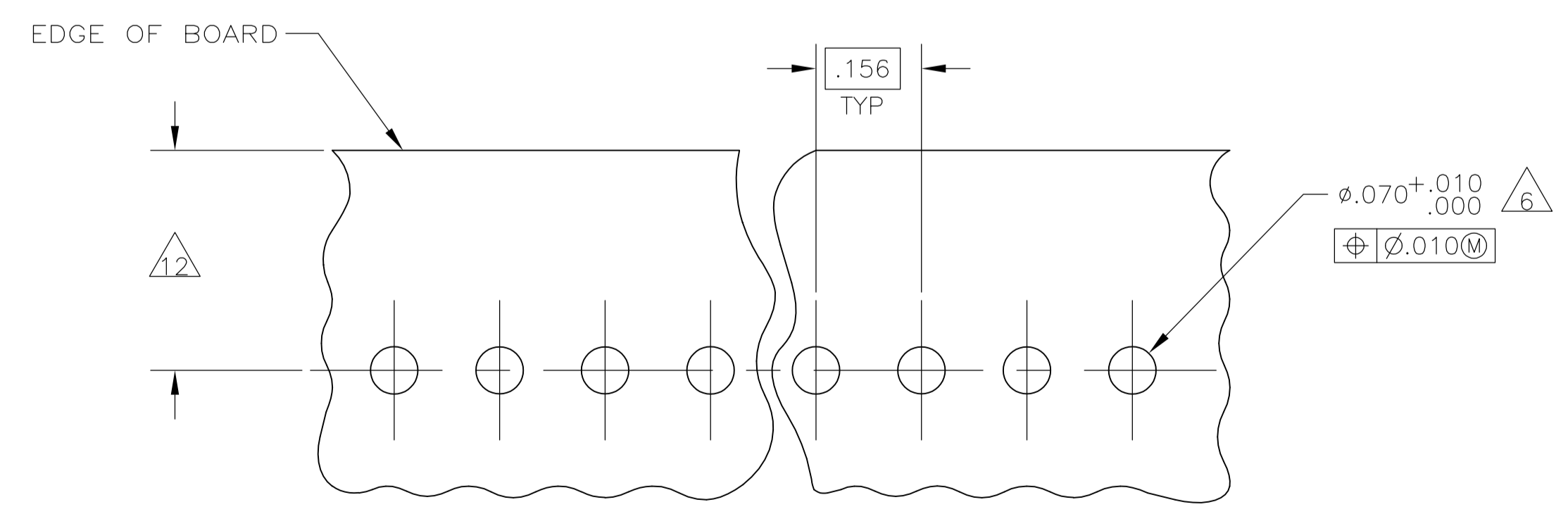

FIG. 1



RECOMMENDED MOUNTING HOLE PATTERN FOR .063 THICK P.C. BOARD

.073	1.85		
.070	1.78		
.068	1.73		
.065	1.65	1.000	25.40
.063	1.60	.450	11.43
.060	1.52	.425	10.80
.045	1.14	.400	10.16
.030	0.76	.345	8.76
.015	0.38	.325	8.26
.012	0.30	.300	7.62
.010	0.25	.212	5.38
.008	0.20	.180	4.57
.005	0.13	.156	3.96
.003	0.08	.125	3.18
.001	0.03	.078	1.98
IN	MM	IN	MM

CONVERSION TABLE

2	95.10	3.744	24	2-640389-4
2	91.14	3.588	23	2-640389-3
2	87.17	3.432	22	2-640389-2
2	83.21	3.276	21	2-640389-1
2	79.25	3.120	20	2-640389-0
2	75.29	2.964	19	1-640389-9
2	71.32	2.808	18	1-640389-8
2	67.36	2.652	17	1-640389-7
2	63.40	2.496	16	1-640389-6
2	59.44	2.340	15	1-640389-5
2	55.47	2.184	14	1-640389-4
2	51.51	2.028	13	1-640389-3
2	47.55	1.872	12	1-640389-2
2	43.59	1.716	11	1-640389-1
2	39.62	1.560	10	1-640389-0
2	35.66	1.404	9	640389-9
1	31.70	1.248	8	640389-8
1	27.74	1.092	7	640389-7
1	23.77	.936	6	640389-6
1	19.81	.780	5	640389-5
1	15.85	.624	4	640389-4
1	11.89	.468	3	640389-3
1	7.92	.312	2	640389-2
FIG NO	MM	[IN]	NUMBER OF POSITIONS	PART NUMBER

THIS DRAWING IS A CONTROLLED DOCUMENT.

DIMENSIONS: INCHES	TOLERANCES UNLESS OTHERWISE SPECIFIED:	0 PLC ± -	1 PLC ± -	2 PLC ± -	3 PLC ± .005	4 PLC ± -	ANGLES ± -
--------------------	--	-----------	-----------	-----------	--------------	-----------	------------

MATERIAL: A FINISH: 7

APPROVED: D. ROSSI	DESIGNED: S. HOOVER	DATE: 05NOV02	BY: Tyco Electronics
PRODUCT SPEC	NAME	SIZE	SCALE
APPLICATION SPEC	MTA-156 HEADER ASSEMBLY, FRICTION LOCK, RIGHT ANGLE, FRONT BEND .045 SQUARE POST, TIN PLATED	A1	5:1
WEIGHT	DRAWING NO. 00779	REV	1
CUSTOMER DRAWING	640389	SHEET	1 OF 1

RESTRICTED TO

