

Distributed by:

JAMECO[®]
ELECTRONICS

www.Jameco.com ♦ 1-800-831-4242

The content and copyrights of the attached
material are the property of its owner.

Jameco Part Number 856052

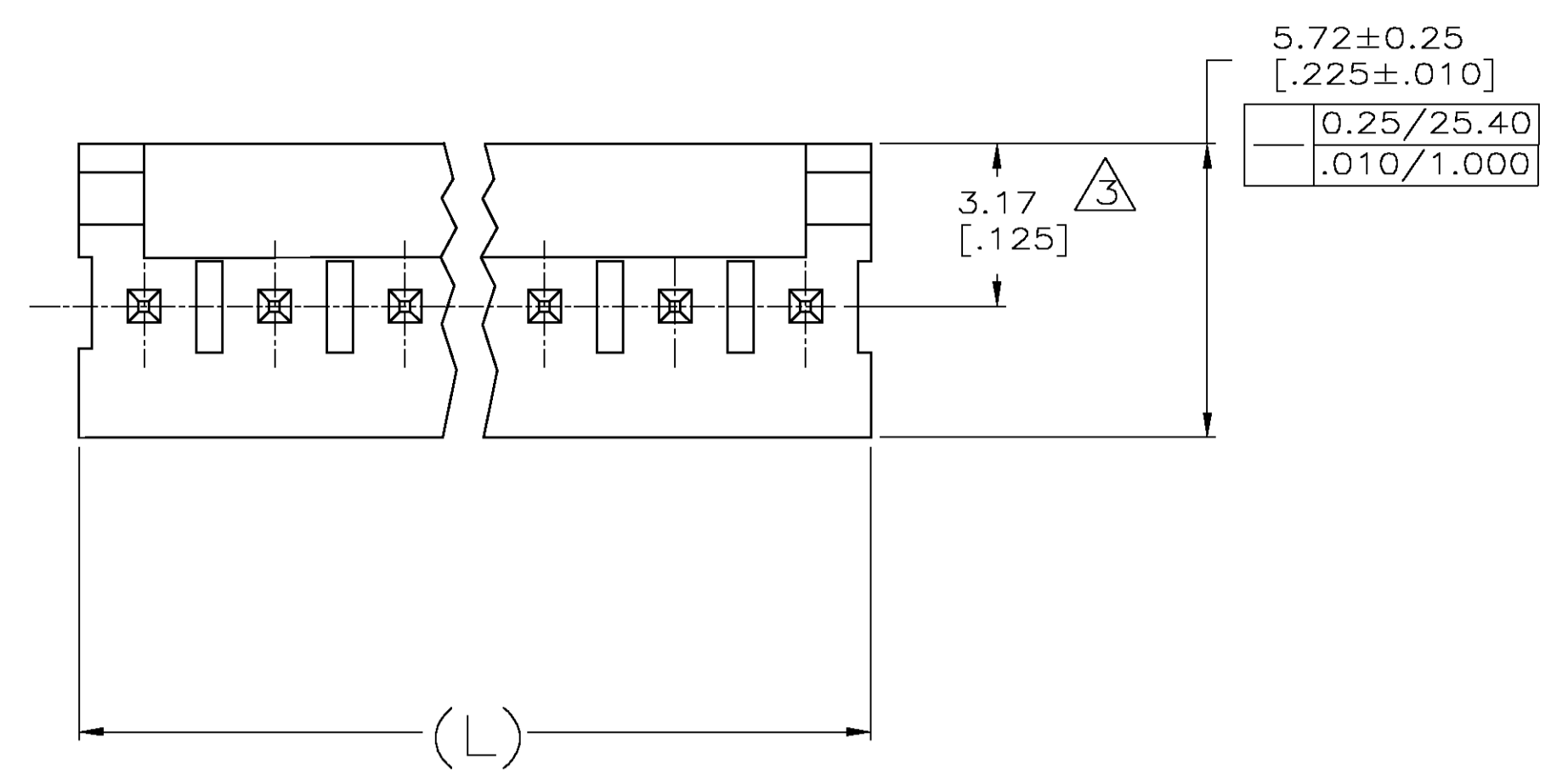

- 1 POST TO WITHSTAND 13 NEWTONS (3 LBS) MINIMUM AXIAL FORCE IN BOTH DIRECTIONS SHOWN WITHOUT DISLODGING.
- 2 TOLERANCES APPLY TO SOLDER SIDE OF BOARD.
- 3 MEASURED AT -A-
- 4 PLASTIC FLASH PERMITTED IN THIS AREA.
- 5. PARTS COMPLY WITH AMP SOLDERABILITY SPEC. NO. 109-11-2.
- 6 ONE HOLE MAY BE UNDERSIZED 0.81-0.89 [.032-.035] DIA. FOR ASSEMBLY RETENTION DURING WAVE SOLDERING.
- 7 MATERIAL: HEADER-THERMOPLASTIC POLYESTER
94V-0 (NATURAL)
POST-COPPER ALLOY
FINISH-USE PLATING NOTES 13 & 14 FOR -2 THRU -28
AND NOTES 13 & 15 FOR -32 THRU -58

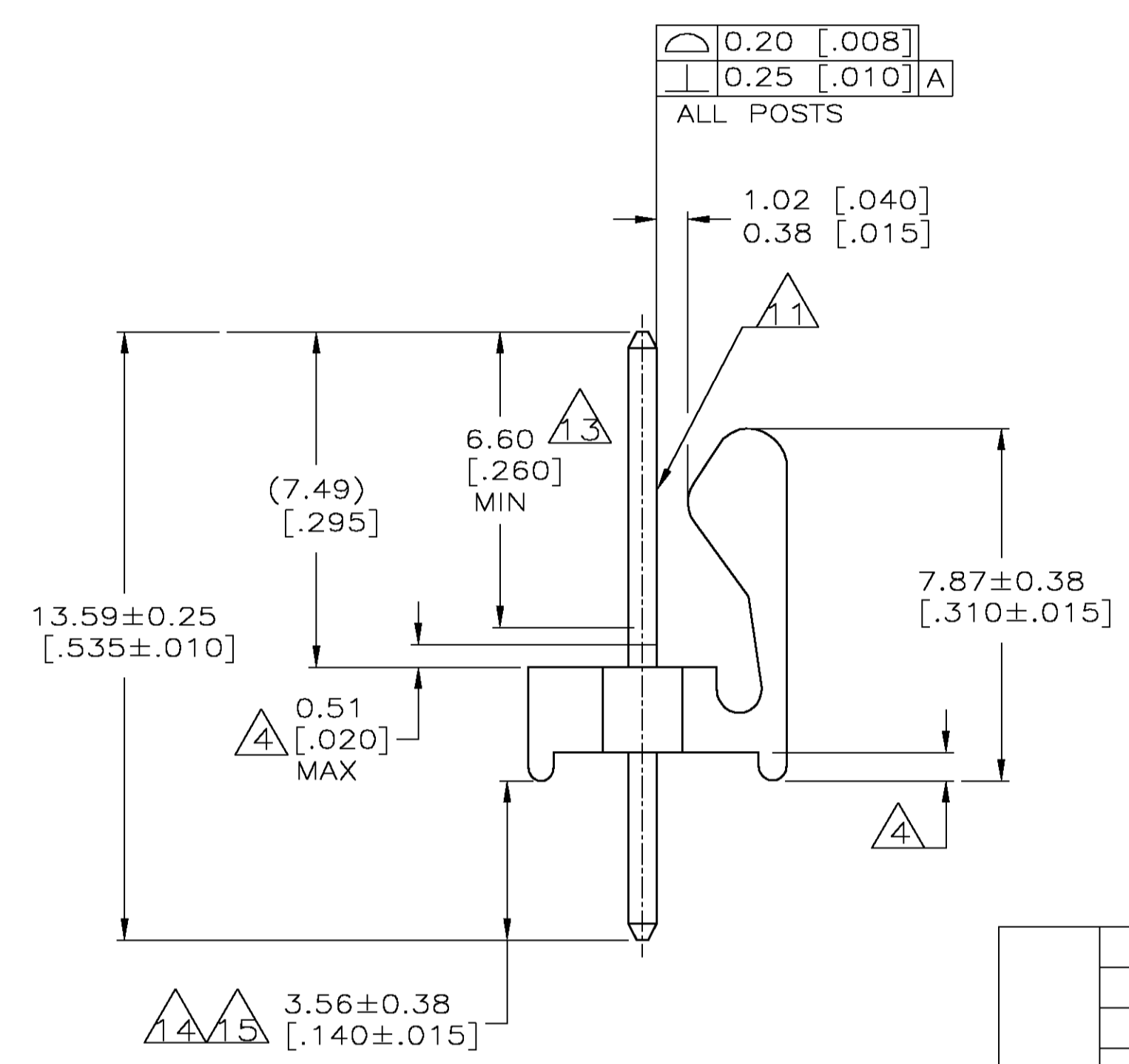
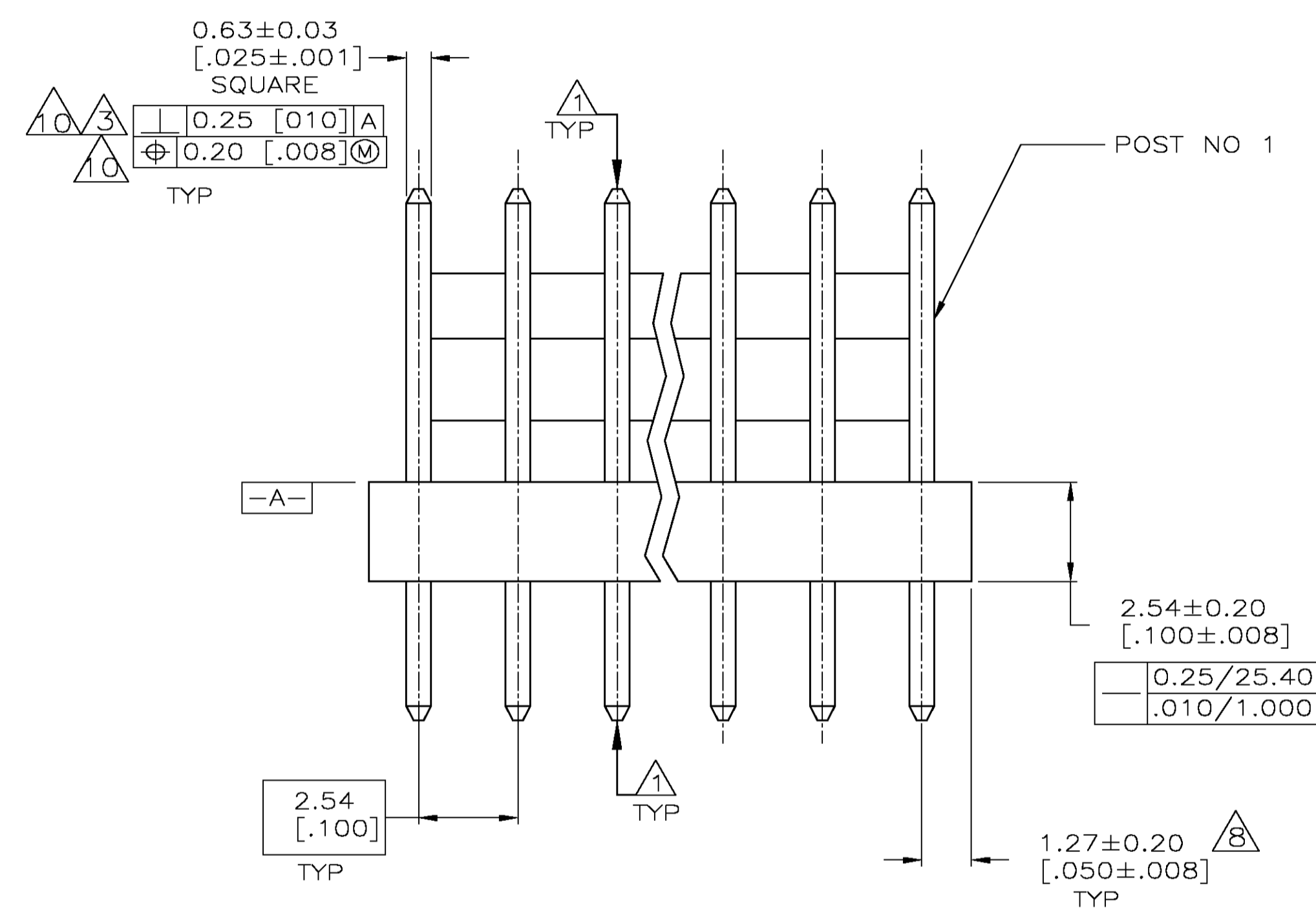

- 8 COORDINATE DIMENSION APPLIES FROM CENTER OF ACTUAL FEATURE.
- 9. PLASTIC BURRS CAUSED BY CUT-OFF TOOLING ARE PERMITTED WITHIN THE MAXIMUM TOLERANCE ENVELOPE.
- 10 POSTS TO BE MEASURED WHEN STRIP IS HELD FLAT.
- 11 POST MUST WITHSTAND TWO 90° BENDS AGAINST EXTRUSION WITHOUT BREAKING.
- 12 DIMENSION SHOULD BE 3.30 [.130] MIN WHEN MATING WITH A MTA-100 CONNECTOR ASSEMBLY OR A CST-100 CONNECTOR ASSEMBLY.
- 13 PLATING: GOLD PLATE AREA, 0.00038 [.000015] MINIMUM, ALL SIDES, OVER NICKEL UNDERPLATE, 0.00127 [.000050] MINIMUM, ALL SIDES AND ENTIRE LENGTH OF POST.
- 14 PLATING: BRIGHT TIN/LEAD (93/7) PLATE AREA, 0.00381-0.00889 [.000150-.000350] THICK, ALL FOUR SIDES 3.56 [.140] MINIMUM.
- 15 PLATING: MATTE TIN PLATE AREA, 0.00381-0.00889 [.000150-.000350] THICK, ALL FOUR SIDES 3.56 [.140] MINIMUM.

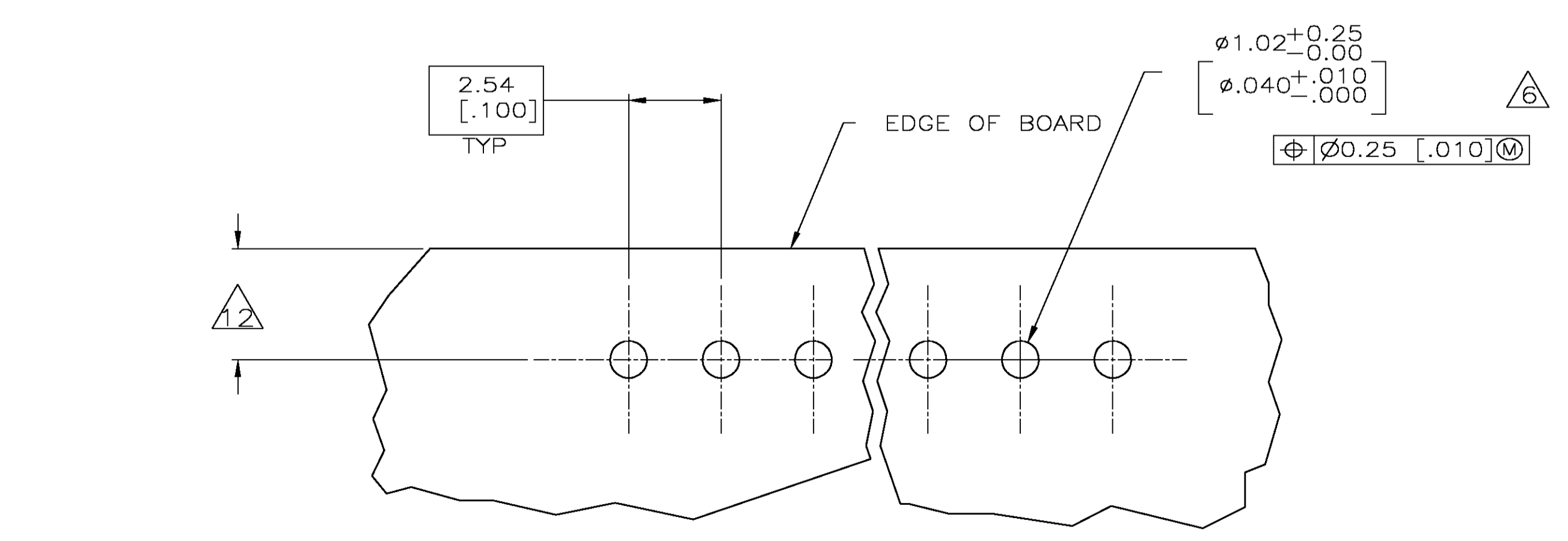

RECOMMENDED MOUNTING HOLE PATTERN FOR 1.60 [0.063] THICK P.C. BOARD

71.12 [2.800]	28	5-641126-8
68.58 [2.700]	27	5-641126-7
66.04 [2.600]	26	5-641126-6
63.50 [2.500]	25	5-641126-5
60.96 [2.400]	24	5-641126-4
58.42 [2.300]	23	5-641126-3
55.88 [2.200]	22	5-641126-2
53.34 [2.100]	21	5-641126-1
50.80 [2.000]	20	5-641126-0
48.26 [1.900]	19	4-641126-9
45.72 [1.800]	18	4-641126-8
43.18 [1.700]	17	4-641126-7
40.64 [1.600]	16	4-641126-6
38.10 [1.500]	15	4-641126-5
35.56 [1.400]	14	4-641126-4
33.02 [1.300]	13	4-641126-3
30.48 [1.200]	12	4-641126-2
27.94 [1.100]	11	4-641126-1
25.40 [1.000]	10	4-641126-0
22.86 [.900]	9	3-641126-9
20.32 [.800]	8	3-641126-8
17.78 [.700]	7	3-641126-7
15.24 [.600]	6	3-641126-6
12.70 [.500]	5	3-641126-5
10.16 [.400]	4	3-641126-4
7.62 [.300]	3	3-641126-3
5.08 [.200]	2	3-641126-2
DIM (L)	NO.OF POSN	ASSEMBLY

71.12 [2.800]	28	2-641126-8
68.58 [2.700]	27	2-641126-7
66.04 [2.600]	26	2-641126-6
63.50 [2.500]	25	2-641126-5
60.96 [2.400]	24	2-641126-4
58.42 [2.300]	23	2-641126-3
55.88 [2.200]	22	2-641126-2
53.34 [2.100]	21	2-641126-1
50.80 [2.000]	20	2-641126-0
48.26 [1.900]	19	1-641126-9
45.72 [1.800]	18	1-641126-8
43.18 [1.700]	17	1-641126-7
40.64 [1.600]	16	1-641126-6
38.10 [1.500]	15	1-641126-5
35.56 [1.400]	14	1-641126-4
33.02 [1.300]	13	1-641126-3
30.48 [1.200]	12	1-641126-2
27.94 [1.100]	11	1-641126-1
25.40 [1.000]	10	1-641126-0
22.86 [.900]	9	641126-9
20.32 [.800]	8	641126-8
17.78 [.700]	7	641126-7
15.24 [.600]	6	641126-6
12.70 [.500]	5	641126-5
10.16 [.400]	4	641126-4
7.62 [.300]	3	641126-3
5.08 [.200]	2	641126-2
DIM (L)	NO.OF POSN	ASSEMBLY



THIS DRAWING IS A CONTROLLED DOCUMENT.

DIMENSIONS: mm [INCHES]	TOLERANCES UNLESS OTHERWISE SPECIFIED:	0 PLC ±	1 PLC ±	2 PLC ±	3 PLC ±	4 PLC ±	ANGLES ±	FINISH ±
		±	±	±	±	±	±	±

APPROVED: D. BOSSI
 DATE: 26-JAN-2005
 NAME: MTA-100 HEADER ASSEMBLY, FRICTION LOCK, NOTCHED, .025 SQUARE STRAIGHT POST, .000015 GOLD PLATED

SIZE: A1
 CAGE CODE: 00779
 DRAWING NO: 641126
 WEIGHT: 0.0015
 CUSTOMER DRAWING: YES
 SCALE: 8:1
 SHEET: 1 OF 1
 REV: Y