

- 1 POST TO WITHSTAND 13 NEWTONS (3 LBS) MIN. AXIAL FORCE IN BOTH DIRECTIONS SHOWN WITHOUT DISLODGING.
- 2 TOLERANCES APPLY TO SOLDER SIDE OF BOARD.
- 3 MEASURED AT SURFACE  $\overline{-A-}$
- 4 PLASTIC FLASH PERMITTED IN THIS AREA.
- 5 PARTS COMPLY WITH AMP SOLDERABILITY SPEC. NO. 109-11-2.
- 6 ONE HOLE MAY BE UNDERSIZED (.032-.035 DIA) FOR ASSEMBLY RETENTION DURING WAVE SOLDERING.
- 7 MATERIAL: HEADER-THERMOPLASTIC POLYESTER  
UL94V-0(NATURAL)  
POST-COPPER ALLOY (SEE NOTES 13 & 14 FOR PLATING)
- 8 COORDINATE DIMENSION APPLIES FROM CENTER OF ACTUAL FEATURE.
- 9 PLASTIC BURRS CAUSED BY CUT-OFF TOOLING ARE PERMITTED WITHIN THE MAXIMUM TOLERANCE ENVELOPE.
- 10 POSTS TO BE MEASURED WHEN STRIP IS HELD FLAT.
- 11 POSTS MUST WITHSTAND TWO 90° BENDS AGAINST EXTRUSION WITHOUT BREAKING.
- 12 DIMENSION SHOULD BE .130 MIN WHEN MATING WITH A MTA 100 CONNECTOR ASSEMBLY OR A CST 100 CONNECTOR.
- 13 GOLD PLATE AREA, .000030 MIN., ALL SIDES, OVER NICKEL UNDERPLATE, .000050 MIN., ALL SIDES AND ENTIRE LENGTH OF POST.
- 14 BRIGHT TIN/LEAD (93/7) PLATE AREA, .000150-.000350 THICK, ALL FOUR SIDES, .140 MIN.
- 15 TIN PLATE AREA, .000150-.000350 THICK, ALL FOUR SIDES, .140 MIN.

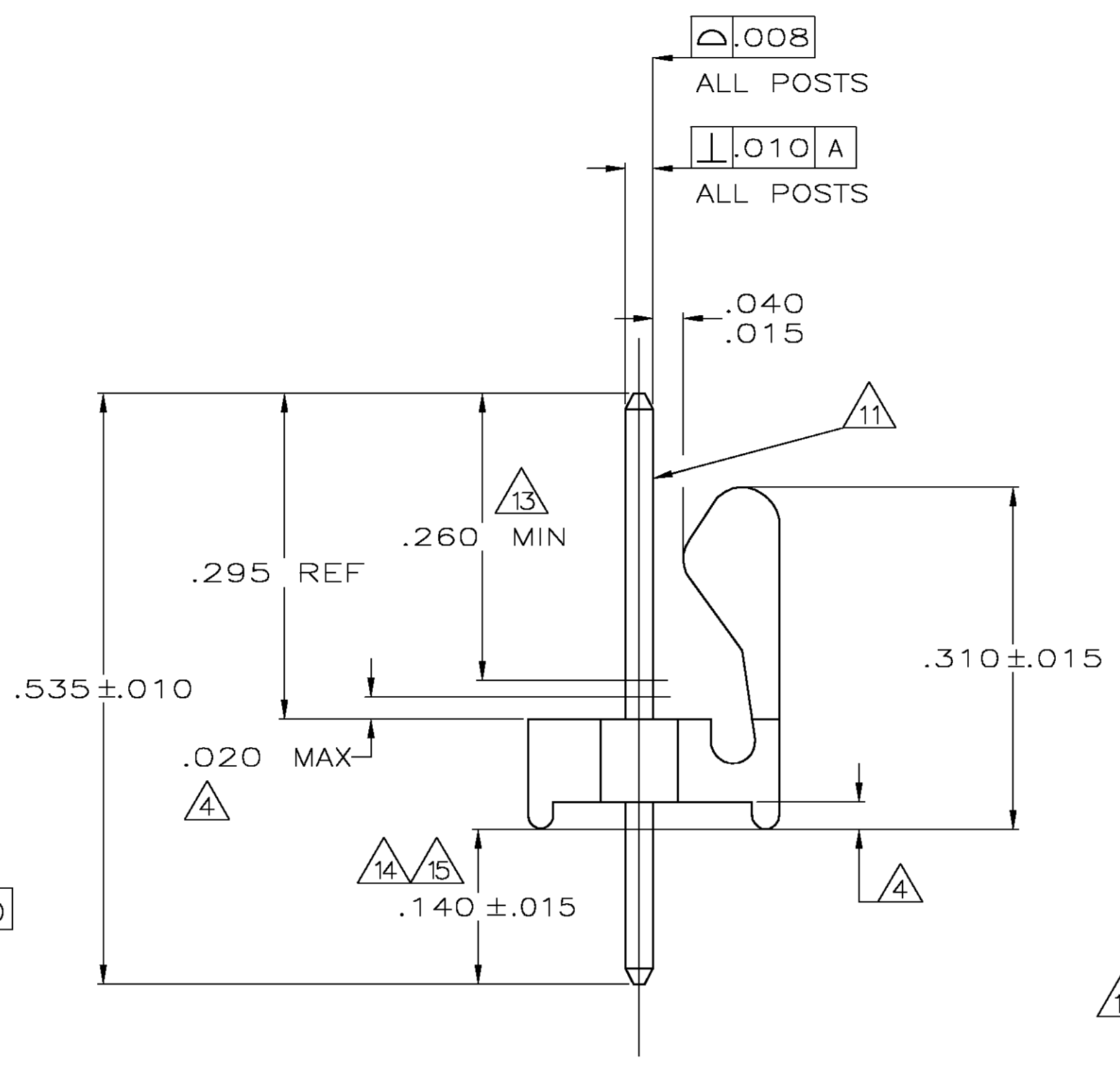
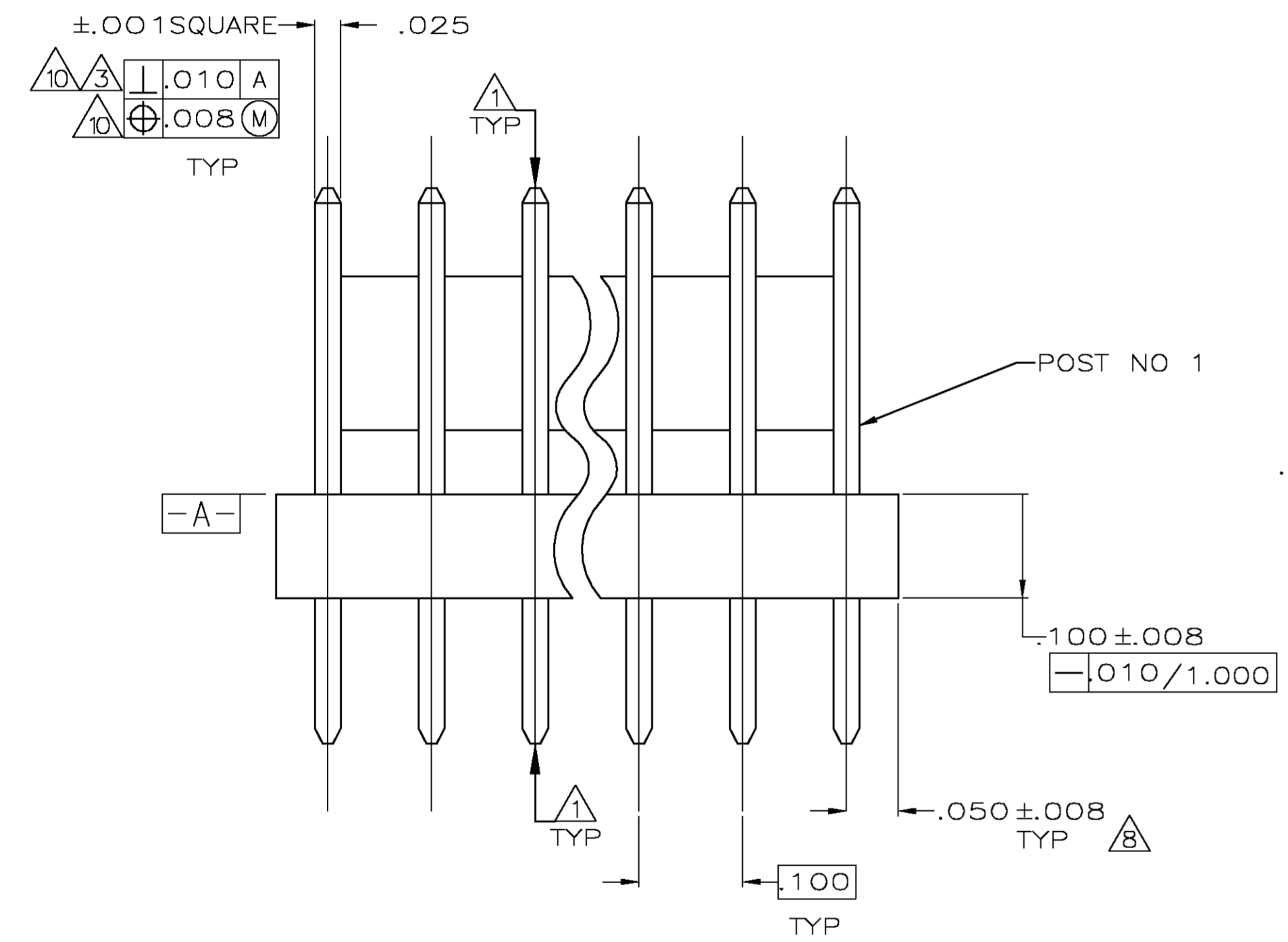

2.800	71.12	28	5-641215-8
2.700	68.58	27	5-641215-7
2.600	66.04	26	5-641215-6
2.500	63.50	25	5-641215-5
2.400	60.96	24	5-641215-4
2.300	58.42	23	5-641215-3
2.200	55.88	22	5-641215-2
2.100	53.34	21	5-641215-1
2.000	50.80	20	5-641215-0
1.900	48.26	19	4-641215-9
1.800	45.72	18	4-641215-8
1.700	43.18	17	4-641215-7
1.600	40.64	16	4-641215-6
1.500	38.10	15	4-641215-5
1.400	35.56	14	4-641215-4
1.300	33.02	13	4-641215-3
1.200	30.48	12	4-641215-2
1.100	27.94	11	4-641215-1
1.000	25.40	10	4-641215-0
.900	22.86	9	3-641215-9
.800	20.32	8	3-641215-8
.700	17.78	7	3-641215-7
.600	15.24	6	3-641215-6
.500	12.70	5	3-641215-5
.400	10.16	4	3-641215-4
.300	7.62	3	3-641215-3
.200	5.08	2	3-641215-2
IN	MM	NO OF POSITIONS	PART NUMBER
L			

2.800	71.12	28	2-641215-8
2.700	68.58	27	2-641215-7
2.600	66.04	26	2-641215-6
2.500	63.50	25	2-641215-5
2.400	60.96	24	2-641215-4
2.300	58.42	23	2-641215-3
2.200	55.88	22	2-641215-2
2.100	53.34	21	2-641215-1
2.000	50.80	20	2-641215-0
1.900	48.26	19	1-641215-9
1.800	45.72	18	1-641215-8
1.700	43.18	17	1-641215-7
1.600	40.64	16	1-641215-6
1.500	38.10	15	1-641215-5
1.400	35.56	14	1-641215-4
1.300	33.02	13	1-641215-3
1.200	30.48	12	1-641215-2
1.100	27.94	11	1-641215-1
1.000	25.40	10	1-641215-0
.900	22.86	9	641215-9
.800	20.32	8	641215-8
.700	17.78	7	641215-7
.600	15.24	6	641215-6
.500	12.70	5	641215-5
.400	10.16	4	641215-4
.300	7.62	3	641215-3
.200	5.08	2	641215-2
IN	MM	NO OF POSITIONS	PART NUMBER
L			

.040	1.02		
.035	0.89		
.032	0.81		
.025	0.64	1.000	25.40
.020	0.51	.535	13.59
.015	0.38	.310	7.87
.010	0.25	.295	7.49
.008	0.20	.260	6.60
.005	0.13	.225	5.72
.001	0.03	.140	3.56
.000350	0.00889	.130	3.30
.000150	0.00381	.125	3.18
.000050	0.00127	.100	2.54
.000030	0.00076	.063	1.60
.000	0.00	.050	1.27
IN	MM	IN	MM

CONVERSION TABLE

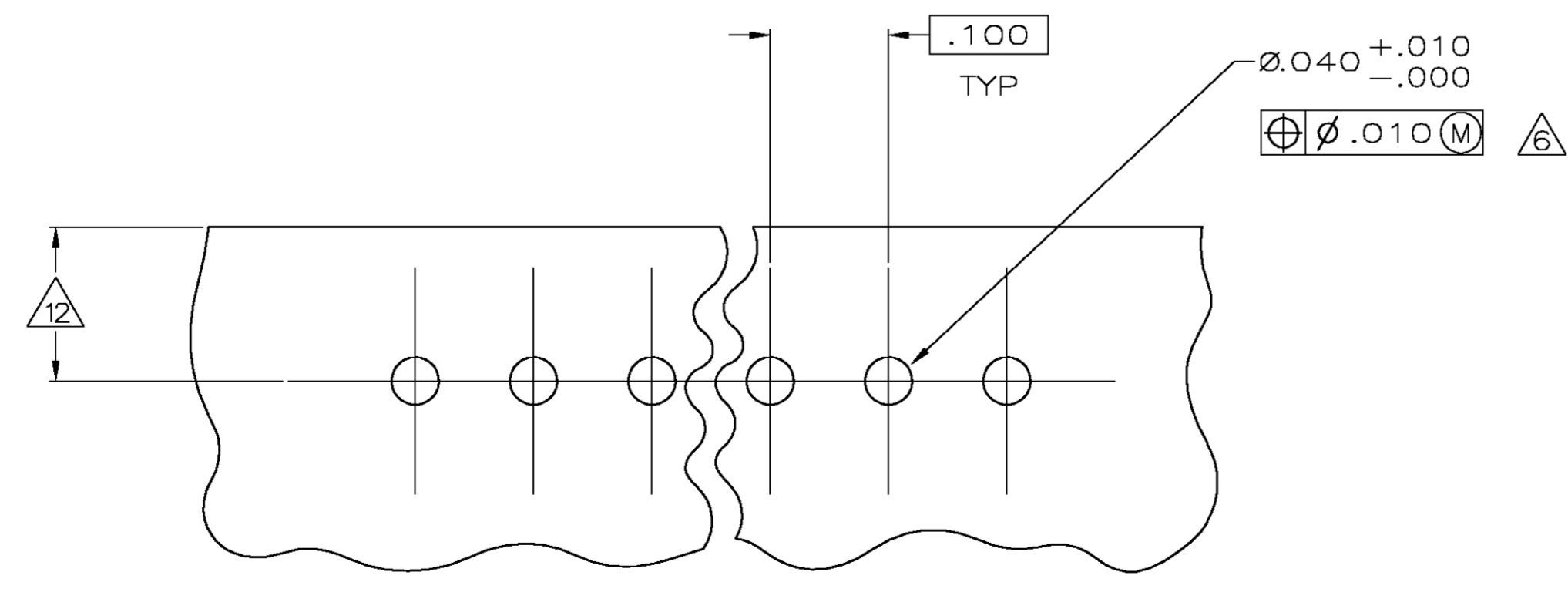

RECOMMENDED MOUNTING HOLE PATTERN FOR .063 THICK P.C. BOARD

METRIC

THIS DRAWING IS A CONTROLLED DOCUMENT.

DIMENSIONS: INCHES	TOLERANCES UNLESS OTHERWISE SPECIFIED:	DW	K. WHITAKER	11JUN2004	Tyco Electronics Corporation Greensboro, NC 27409
0 PLC ± -	1 PLC ± -	CHK	D. BOSSI	11JUN04	
2 PLC ± -	3 PLC ± .005	APD	D. BOSSI	11JUN04	NAME: MTA-100 HEADER ASSEMBLY, FRICTION LOCK, NOTCHED, .025 SQUARE STRAIGHT POST, .000030 GOLD PLATED
4 PLC ± -	ANGLES ± 0.30°	PRODUCT SPEC			
MATERIAL	FINISH	APPLICATION SPEC			SIZE: A1
		WEIGHT			CAGE CODE: 00779
					DRAWING NO: 641215
					RESTRICTED TO: -
					CUSTOMER DRAWING
					SCALE: 8:1
					SHEET 1 OF 1
					REV W