

LOC		DIST		REVISIONS			
CM	00	REV	DATE	BY	CHK	APPD	
		K	14OCT2005	REVIS PER DC38-1208-04			SR

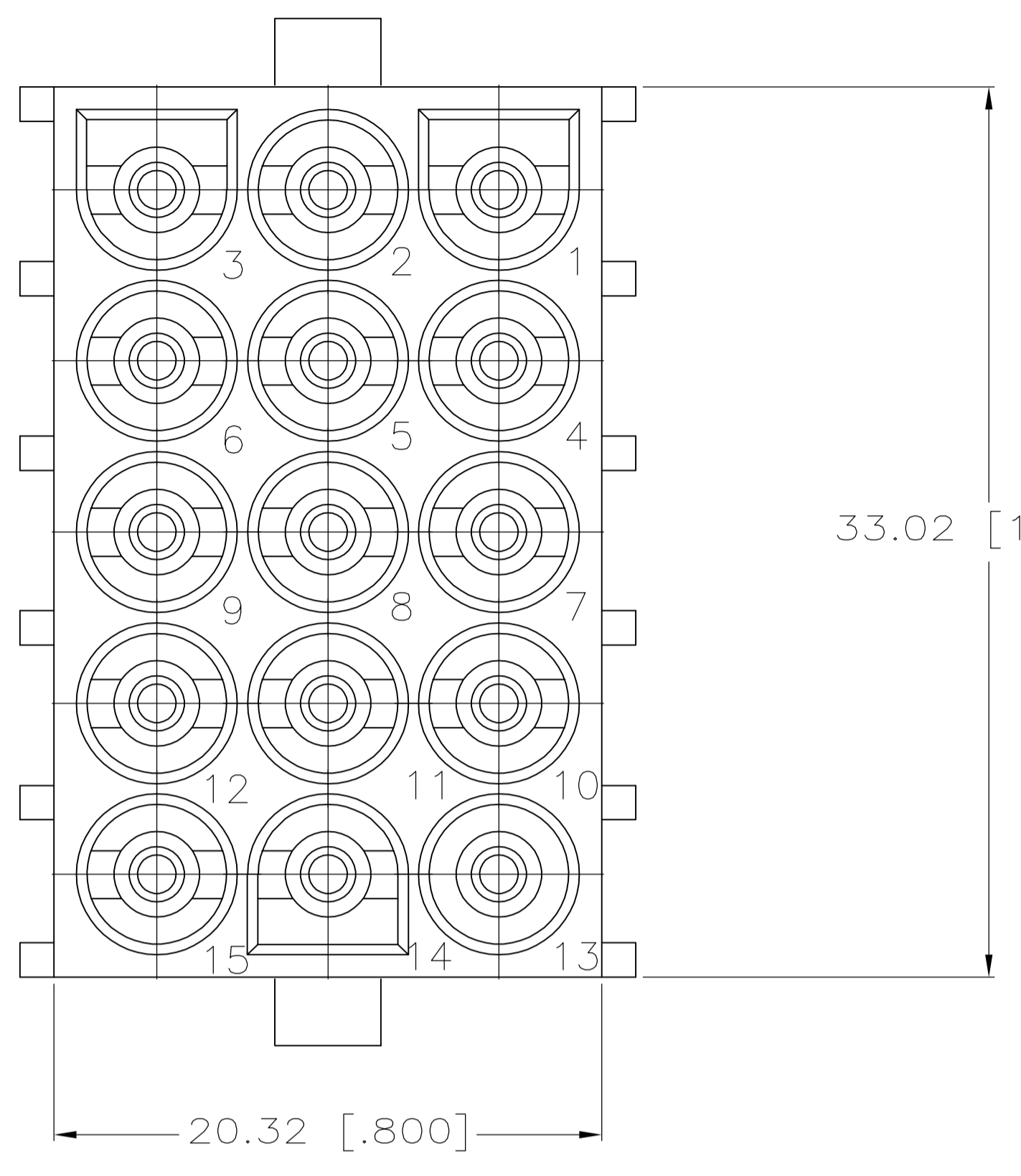

- PARTS MUST COMPLY WITH AMP SOLDERABILITY SPEC 109-11-3.
- MATES WITH HOUSING NO. 350736 USING SOCKET CONTACTS.
- CONTACT IS STAMPED FROM PRE-PLATED STOCK WHICH IS PLATED OVERALL WITH 0.00127 [.000050] NICKEL, THEN STRIPED WITH 0.00076 [.000030] GOLD IN CONTACT AREA INDICATED AND TIN-LEAD ON SOLDER TAIL END.
- CONTACT IS PLATED OVERALL WITH 0.00127 [.000050] NICKEL, THEN 0.00076 [.000030] GOLD OVER CONTACT LENGTH INDICATED AND MATTE TIN ON SOLDER TAIL END.

0.25 [.010] MAX CUT-OFF

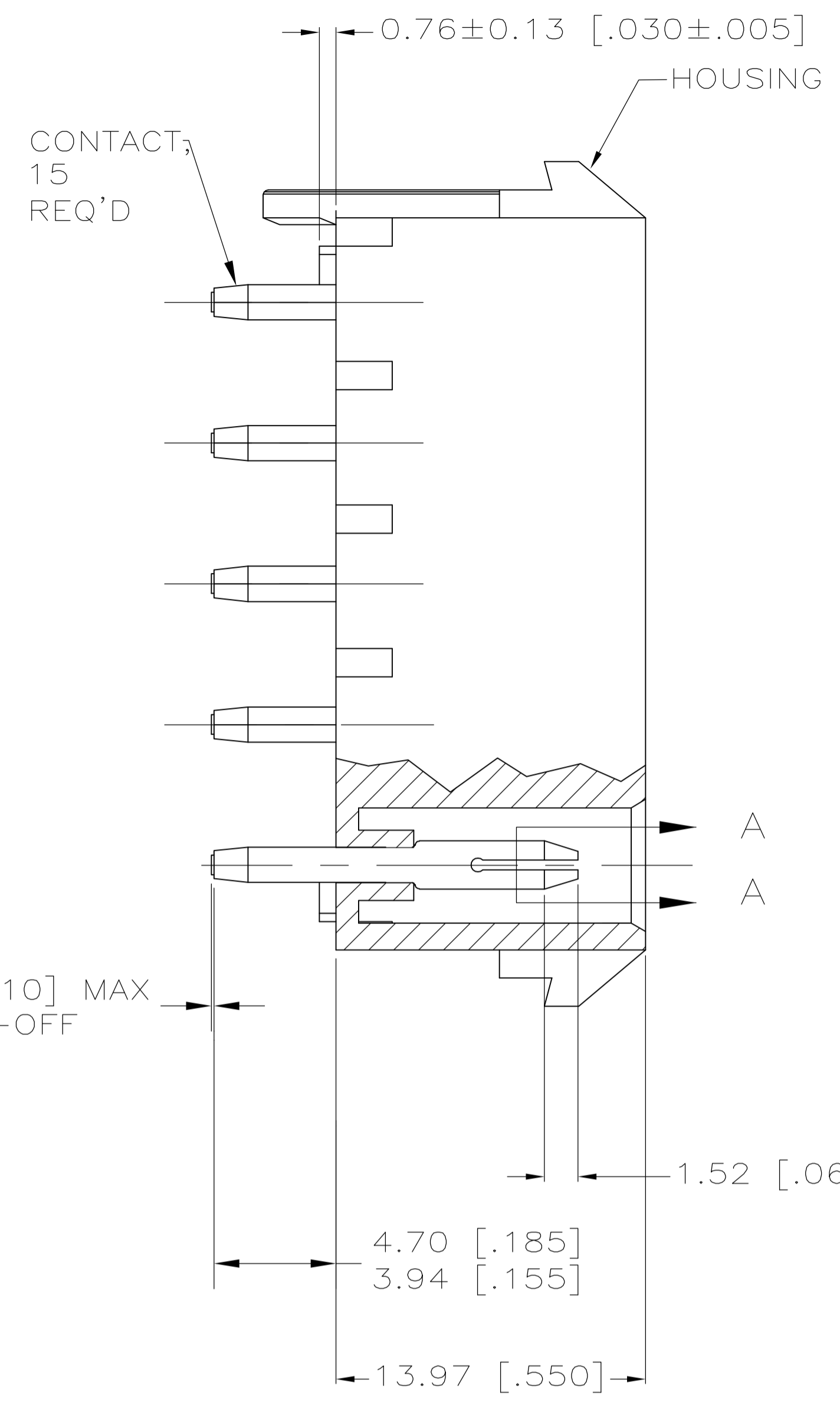
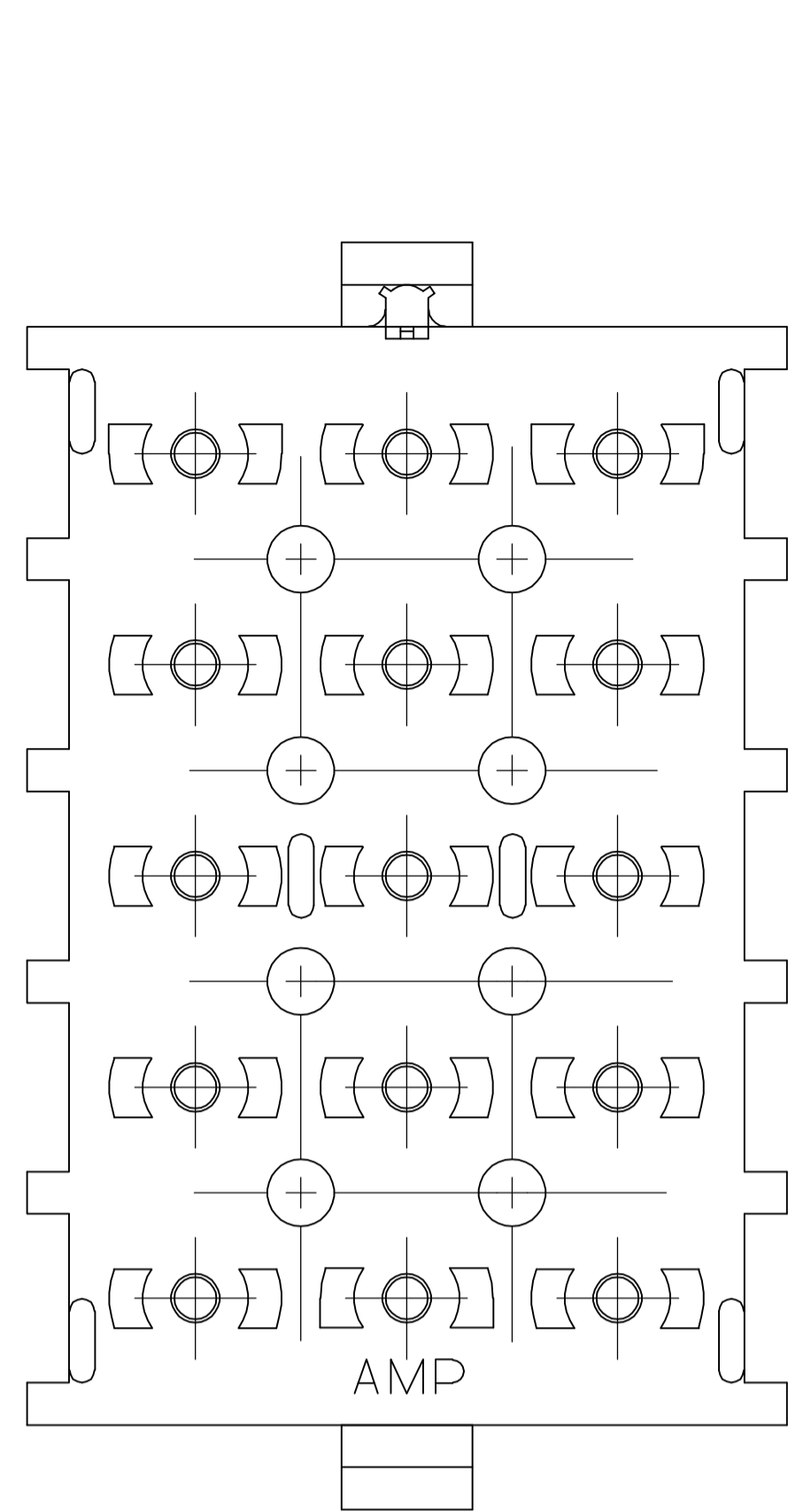
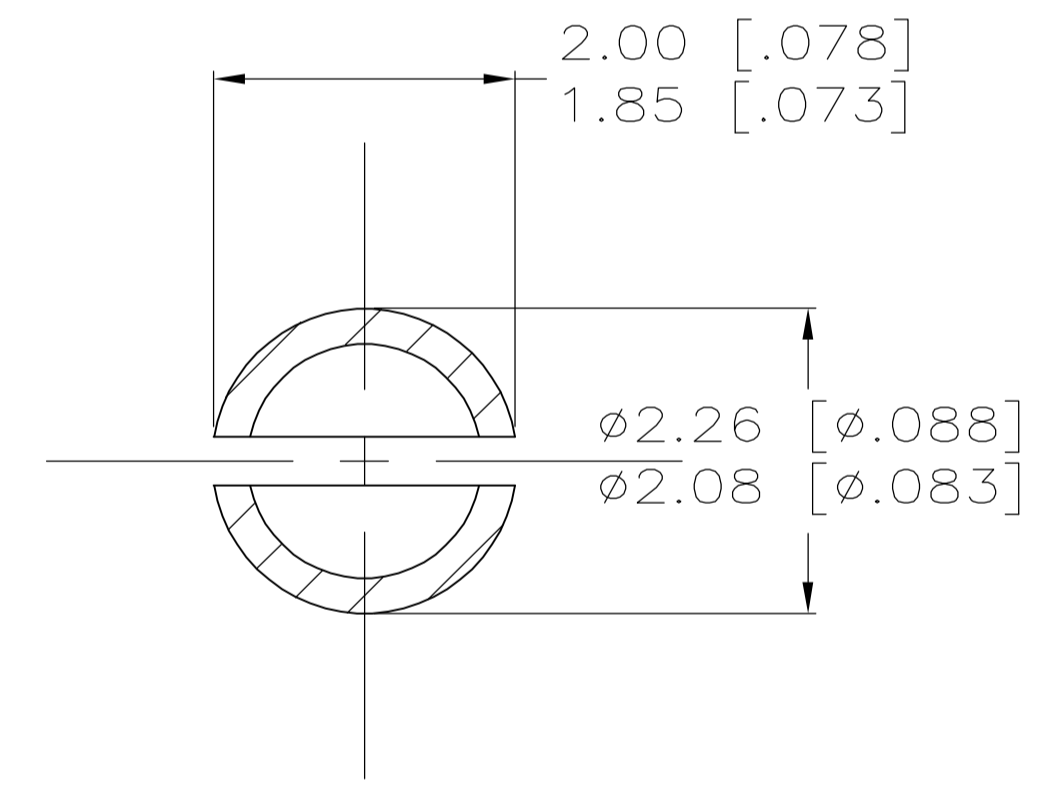

SECTION A-A  
SCALE 12:1

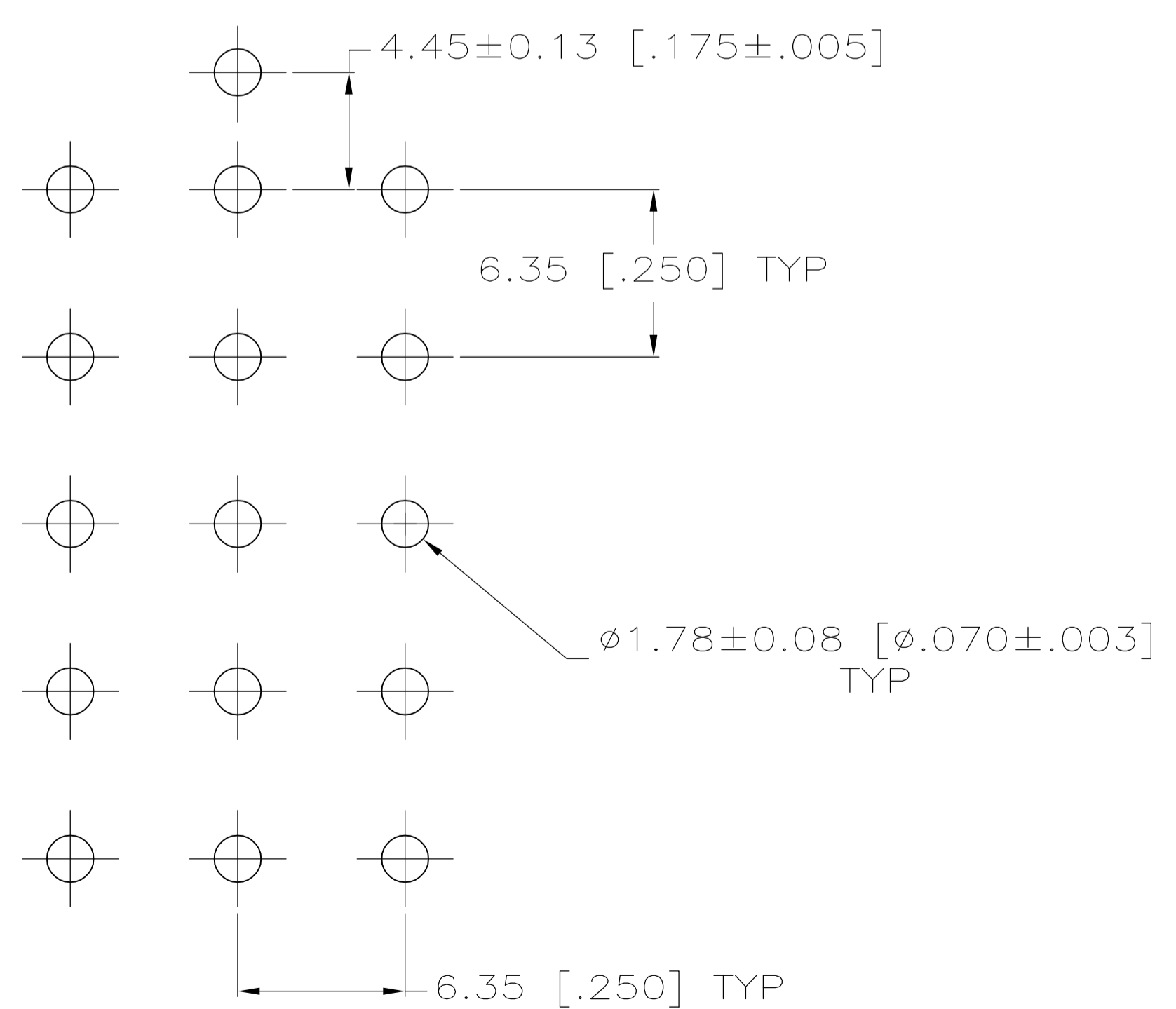

RECOMMENDED LAYOUT FOR 1.58 [.062] THICK PC BOARD

PH BRZ GOLD $\Delta$ 4	NYLON, UL94V-0	641976-4
PH BRZ GOLD $\Delta$ 3	NYLON, UL94V-0	641976-2
PH BRZ TIN	NYLON, UL94V-0	641976-1
CONTACT	HOUSING	PART NO

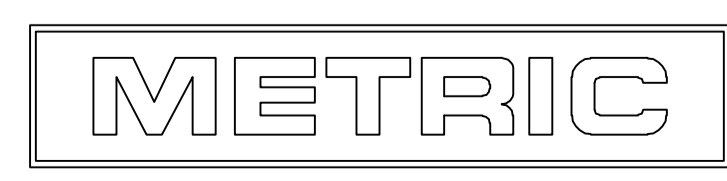

THIS DRAWING IS A CONTROLLED DOCUMENT.

DIMENSIONS: mm (INCHES)	TOLERANCES UNLESS OTHERWISE SPECIFIED: 0 PLC ± 1 PLC ± 2 PLC ± 3 PLC ± 0.13 [.005] 4 PLC ± ANGLES ± FINISH	OWN: K. WHITAKER CHK: S. RIDGILL APPD: S. RIDGILL PRODUCT SPEC	14OCT2005 19-NOV-2003 19-NOV-2003	<b>tyco</b> Electronics	Tyco Electronics Corporation Harrisburg, PA 17105-3608
MATERIAL SEE CHART		APPLICATION SPEC	SIZE: A1 CAGE CODE: 00779 DRAWING NO: 641976	RESTRICTED TO	
CUSTOMER DRAWING			SCALE: 5:1	SHEET: 1 OF 1	REV: K