

647877-1 Product Details

[Share](#) [Print](#) [Email](#)

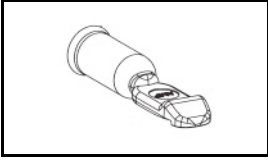

647877-1

TE Internal Number: 647877-1

Active

[View 3D PDF](#)

AMP Power Series Connectors

Always EU RoHS/ELV Compliant
(Statement of Compliance)

Product Highlights:

- 50 Series, 75 Series
- Contact
- Contact - Rated Current = 75 A
- AWG > 0 = No
- Wire/Cable Size = 6 AWG

[View all Features](#)

Quick Links

- ▶ [Pricing & Availability](#)
- ▶ [Search for Tooling](#)
- ▶ [Product Feature Selector](#)
- ▶ [Contact Us About This Product](#)

[Add to My Part List](#)

[Request Sample](#)

[Find Similar Products](#)

[Buy Product](#)

Documentation & Additional Information

Product Drawings:

- [CONTACT, 6 AWG, AMP POWER SERIES 50 / 75](#) (PDF, English)

Catalog Pages/Data Sheets:

- [POWER_CONNECTORS_CATALOG_SEC02_CABLE_MOUNTED](#) (PDF, English)
- [2_PIECE_POWER_CONNECTORS_qrg_4-1773458-1](#) (PDF, English)

Product Specifications:

- None Available

Application Specifications:

- [Power Series 50 Connector Assemblies](#) (PDF, English)

Instruction Sheets:

- [Crimp Tool 1526955-1](#) (PDF, English)

CAD Files: (CAD Format & Compression Information)

- [2D Drawing](#) (DXF, Version A)
- [3D Model](#) (IGES, Version A)
- [3D Model](#) (STEP, Version A)

[List all Documents](#)

Additional Information:

- [Product Line Information](#)

Related Products:

- [Tooling](#)

Product Features (Please use the Product Drawing for all design activity)

Product Type Features:

- Series = 50, 75
- Product Type = Contact
- Barrel Type = Closed Barrel
- UL File Number = E28476
- Wire/Cable Type = Discrete Wire
- Termination Method to Wire/Cable = Crimp

Electrical Characteristics:

- Contact - Rated Current (A) = 75
- AWG > 0 = No
- Operating Voltage Reference = AC, DC, AC/DC
- Operating Voltage (VAC) = 600
- Operating Voltage (VDC) = 600
- Hot Pluggable = No

Housing Features:

- UL Flammability Rating = UL 94V-0

Industry Standards:

- [RoHS/ELV Compliance](#) = RoHS compliant, ELV compliant
- [Lead Free Solder Processes](#) = Not relevant for lead free process
- RoHS/ELV Compliance History = Always was RoHS compliant
- Agency/Standard = UL
- UL Rating = Recognized
- UL Voltage Rating (VAC) = 600
- UL Voltage Rating (VDC) = 600

Conditions for Usage:

- Applies To = Wire/Cable

Termination Features:

- Wire/Cable Size (AWG) = 6
- Wire/Cable Size (mm²) = 13 - 14
- Wire/Cable Size (CMA) = 25,656 - 27,629

Dimensions:

- Length (X-Axis) (mm [in]) = 31.24 [1.230]
- Width (Z-Axis) (mm [in]) = 8.16 [0.321]
- Profile Height (Y-Axis) (mm [in]) = 8.16 [0.321]

Body Features:

- Wire Type = Stranded

Contact Features:

- Contact Plating, Mating Area, Material = Silver
- Contact Plating, Mating Area, Thickness (µm [µin]) = 1.27 [50]
- Contact Type = Pin/Socket
- Contact Design = Cold-headed
- Contact Base Material = Copper

- Accepts Wire Material = Copper

Operation/Application:

- Contact Transmits (Typical Application) = Power
- Application Use = Wire-to-Wire

Packaging Features:

- Packaging Method = Loose Piece

Other:

- Brand = AMP

Corporate Information

[About TE](#)
[Investors](#)
[News Room](#)
[Supplier Portal](#)
[Careers](#)
[Terms & Conditions](#)
[Privacy Policy](#)

Quick Links

[Distributor Inventory](#)
[Product Cross Reference](#)
[Documents & Drawings](#)
[Product Compliance Support Center](#)
[Site Map](#)

Customer Support

[Email or Chat With Us](#)
[Find a Phone Number](#)
[Knowledge Base](#)
[Manage Your Account](#)

Keep Me Informed

LOC	DIST	REVISIONS			
CM	00	REV	DATE	BY	APP'D
		A	12-DEC-03	KW	JE
		B	15APR2008	KW	SR
		BI	23JUL2008	HMR	SR

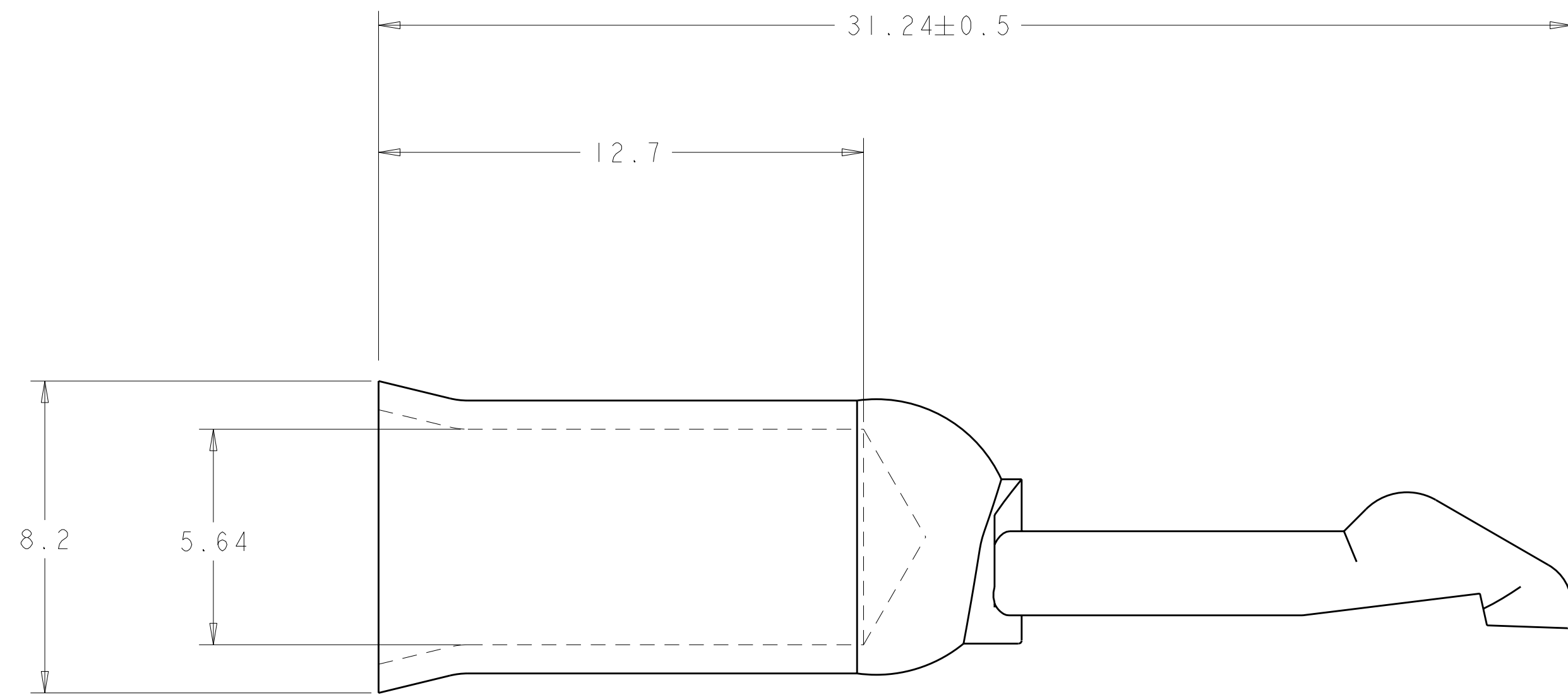
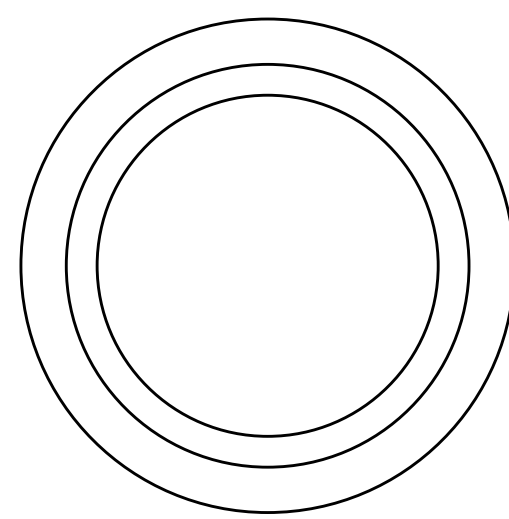
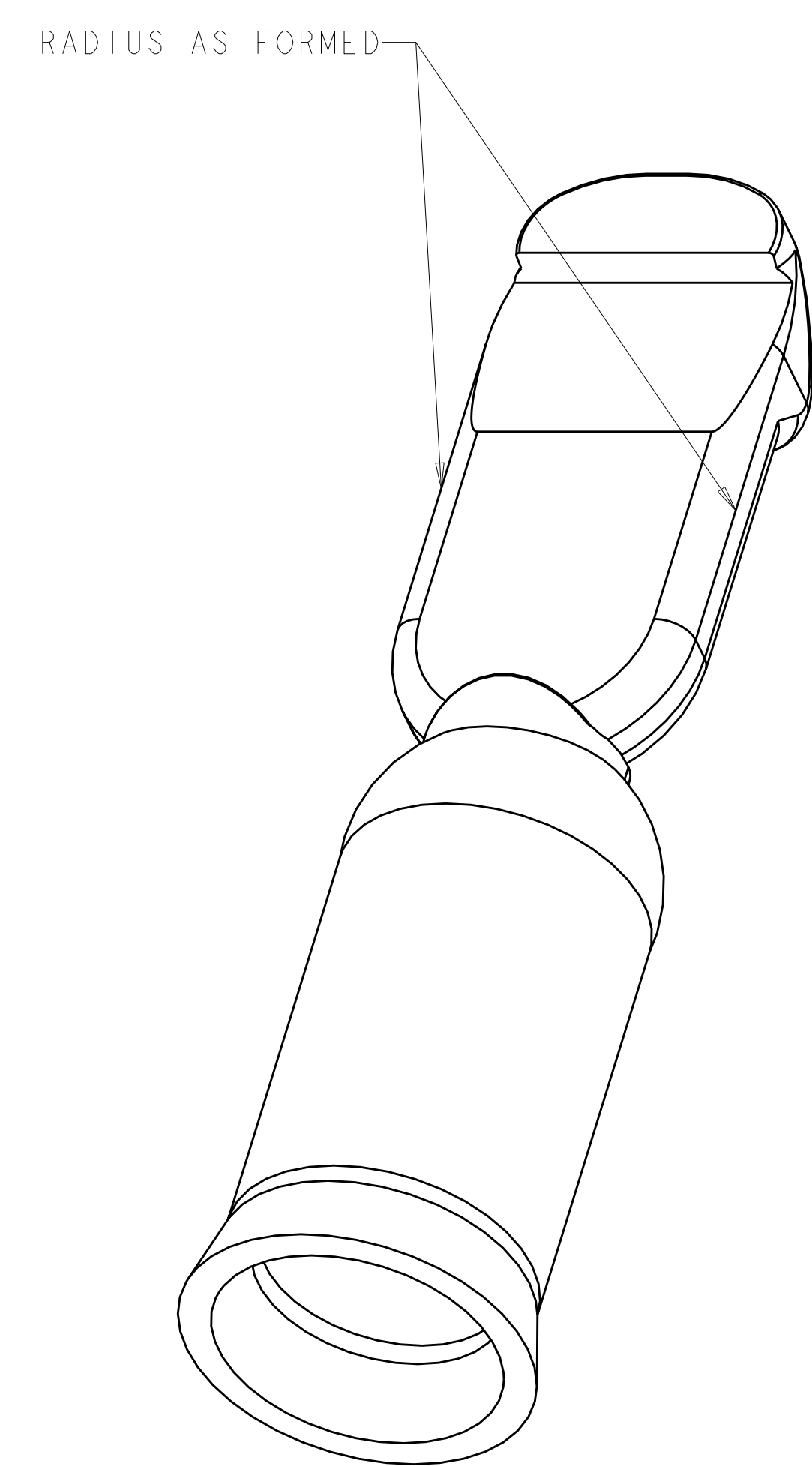
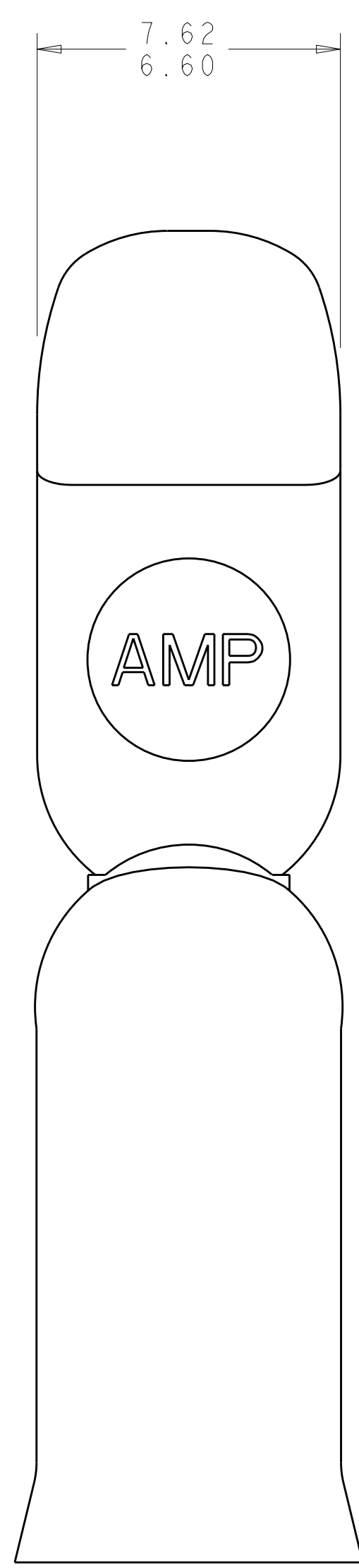

1. MATERIAL: COPPER
2. PLATING: SILVER
3. THIS PRODUCT HAS PASSED VERIFICATION AND AGENCY APPROVALS TESTING AND IS COMPONENT RECOGNIZED PER UL 1977 AND CSA 22.2. TYCO ELECTRONICS PRODUCT QUALIFICATION TESTING IS NOT YET COMPLETE.

647877-1
PART NO

METRIC

<small>THIS DRAWING IS UNPUBLISHED. RELEASED FOR PUBLICATION BY TYCO ELECTRONICS CORPORATION. ALL RIGHTS RESERVED.</small>		DWN: SHANE WUEST 12JUN2001 CHK: KAK 12JUN2001 APP'D: KAK 12JUN2001	Tyco Electronics Harrisburg, PA 17105-3608
DIMENSIONS: mm 	TOLERANCES UNLESS OTHERWISE SPECIFIED: 0 PLC ± 1 PLC ± 2 PLC ±0.13 3 PLC ± 4 PLC ± ANGLES ±5 FINISH	PRODUCT SPEC APPLICATION SPEC WEIGHT CUSTOMER DRAWING	NAME: CONTACT, 6 AWG, AMP POWER SERIES 50 / 75 SIZE: A11 CAGE CODE: 00779 DRAWING NO: 647877 SCALE: 8:1 SHEET: 1 OF 1 REV: BI