

Distributed by:

JAMECO[®]
ELECTRONICS

www.Jameco.com ♦ 1-800-831-4242

The content and copyrights of the attached
material are the property of its owner.

Jameco Part Number 859860

THIS DRAWING IS UNPUBLISHED. RELEASED FOR PUBLICATION
 © COPYRIGHT BY TYCO ELECTRONICS CORPORATION. ALL RIGHTS RESERVED.

LOC		DIST		REVISIONS					
FT		47		P	LTR	DESCRIPTION	DATE	DWN	APVD
				N		0G3B-0344-03	29APR03	TK	GS

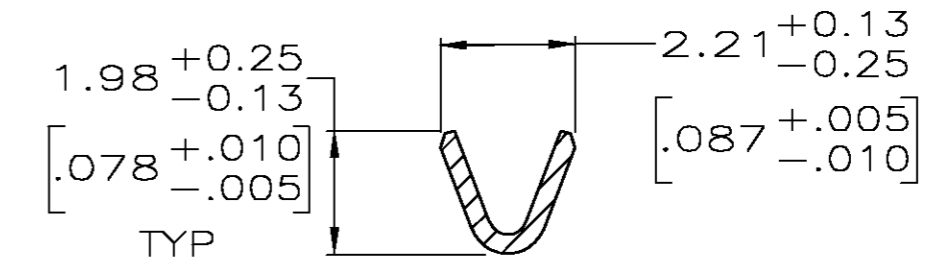
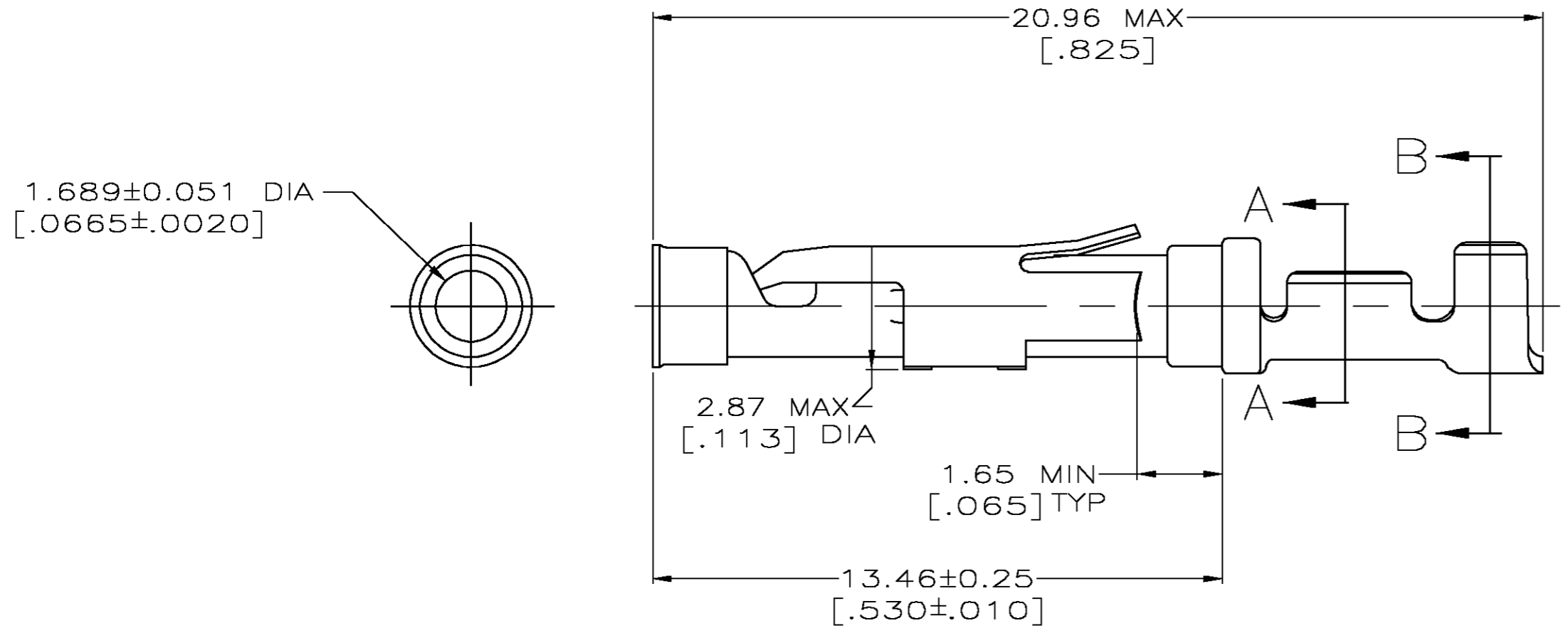
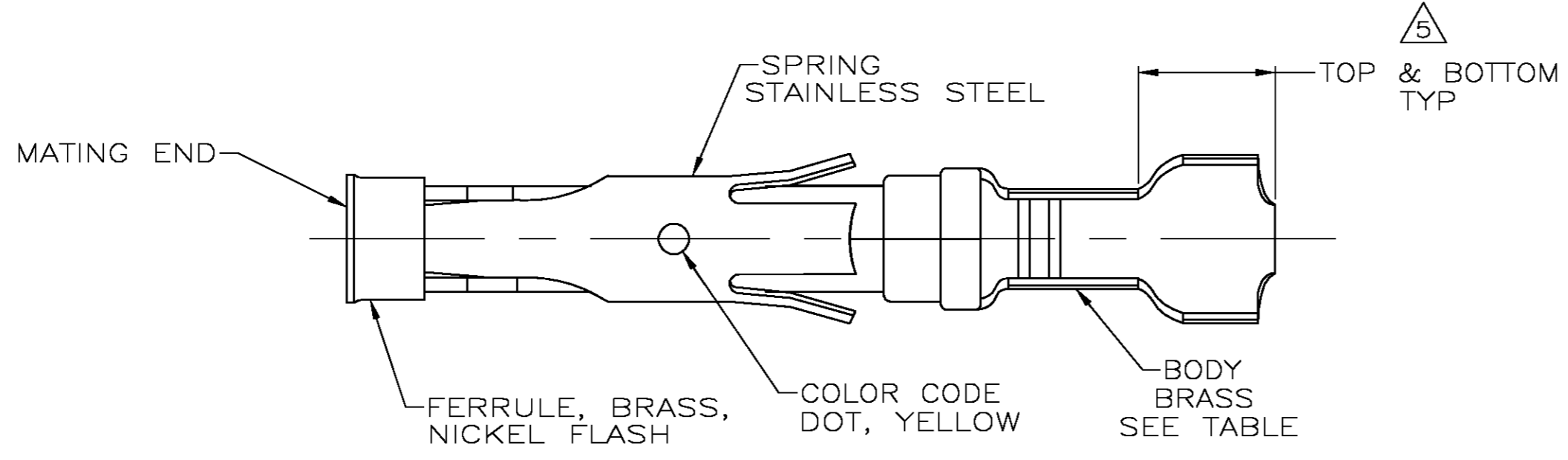

SECTION A-A

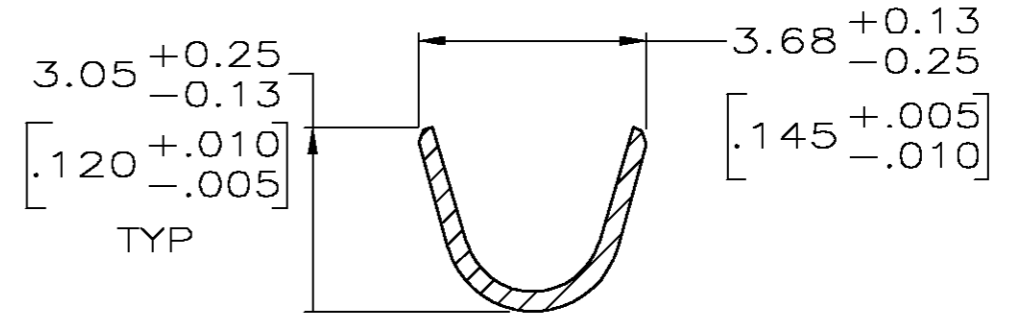

SECTION B-B

- ① 0.76µm [.000030] MIN GOLD PER MIL-G-45204 ON MATING END FOR A LENGTH OF 5.08 [.200] MIN WITH GOLD FLASH ON THE REMAINDER OVER 0.76µm [.000030] MIN NICKEL PER QQ-N-290.
- ② 0.76µm [.000030] MIN GOLD PER MIL-G-45204 ON MATING END FOR A LENGTH OF 5.08 [.200] MIN WITH A UNIFORM GRADIENT TO 0.25µm [.000010] MIN GOLD PER MIL-G-45204 ON THE REMAINDER OVER 0.76µm [.000030] MIN NICKEL PER QQ-N-290.
- ③ 0.38µm [.000015] MIN GOLD PER MIL-G-45204 ON MATING END FOR A LENGTH OF 5.08 [.200] MIN WITH GOLD FLASH ON THE REMAINDER OVER 0.76µm [.000030] MIN NICKEL PER QQ-N-290.
- ④ 1.27µm [.000050] MIN TIN-LEAD PER MIL-T-10727 OVER 0.76µm [.000030] MIN NICKEL PER QQ-N-290.
- ⑤ GOLD PLATING NEED NOT APPEAR IN THIS AREA.
- 6. WIRE RANGE 24-20 AWG. INSULATION RANGE 2.03[.080]-2.54[.100].
- ⑦ 0.38µm [.000015] MIN GOLD PER MIL-G-45204 ON MATING END FOR A LENGTH OF 5.08 [.200] MIN, 1.27µm [.000050] MIN TIN-LEAD PER MIL-T-10727 FOR A LENGTH OF 5.69 [.224] MIN ON OPPOSITE END, BOTH OVER 1.27µm [.000050] MIN NICKEL PER QQ-N-290 ON ENTIRE CONTACT.
- ⑧ 1.27µm [.000050] MIN TIN PER MIL-T-10727 OVER 0.76µm [.000030] MIN NICKEL PER QQ-N-290.

	SMALL PACK	⑧	1-66399-0	1-66399-1
	STANDARD	⑧	1-66331-4	1-66399-0
	SMALL PACK	①	66331-4	66399-9
	SMALL PACK	③	66331-7	66399-8
	SMALL PACK	②	66331-2	66399-7
	SMALL PACK	④	66331-1	66399-6
OBSOLETE	STANDARD	⑦	1-66331-2	66399-5
	STANDARD	①	66331-4	66399-4
	STANDARD	③	66331-7	66399-3
	STANDARD	②	66331-2	66399-2
	STANDARD	④	66331-1	66399-1
	PACKAGING TYPE	BODY FINISH	STRIP P/N REF	PART NO

THIS DRAWING IS A CONTROLLED DOCUMENT.

DIMENSIONS: INCHES	TOLERANCES UNLESS OTHERWISE SPECIFIED:	DWN R.SHIREY 7-30-91	Tyco Electronics Corporation City, State, Zip
		CHK R.STONE 9-19-91	
		APVD J.ESTMAN 9-20-91	NAME SOCKET ASSEMBLY, LOOSE PIECE, TYPE III+
			SIZE A2 CAGE CODE 00779 DRAWING NO C=66399
MATERIAL SEE CALLOUTS	FINISH SEE CALLOUTS	WEIGHT -	RESTRICTED TO -
CUSTOMER DRAWING		SCALE 8:1	SHEET 1 OF 1 REV N