

LOC	DIST	P	F	ZONE	LTR	DESCRIPTION	DATE	APPD
FT	47				J	REV & REDRAWN PER ECN BD3865	9-27-90	AB
					K	REV PER ECN BD4836	04/29/91	RW
					L	ADDED -6 PER NPR 3597 & REV PER BD6295	06/04/92	GS
					M	REV PER EC 0020-745-94	07/06/94	GS
					N	OBSOLETE -6 PER EC 0020-608-96	18 DEC 96	GS
					P	REV PER EC 0320-133-97	7-24-97	PB

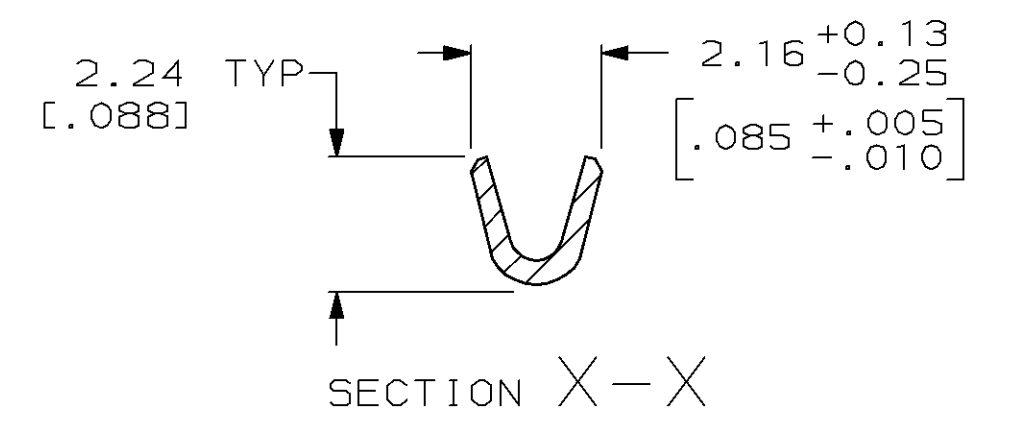
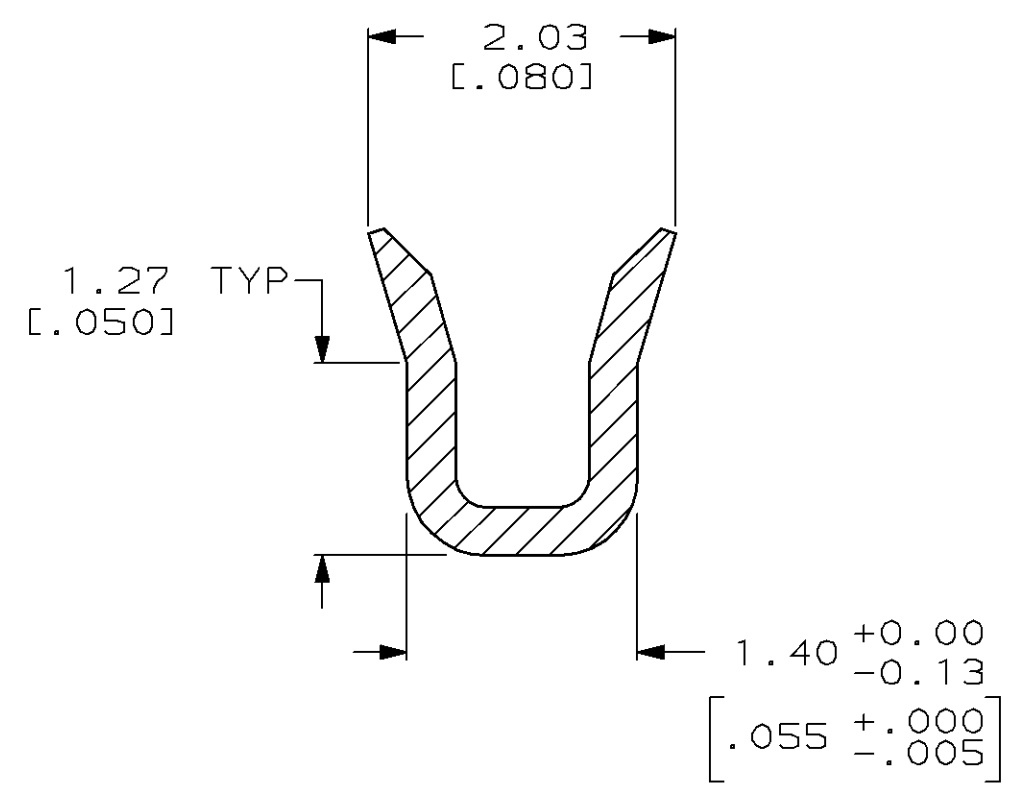
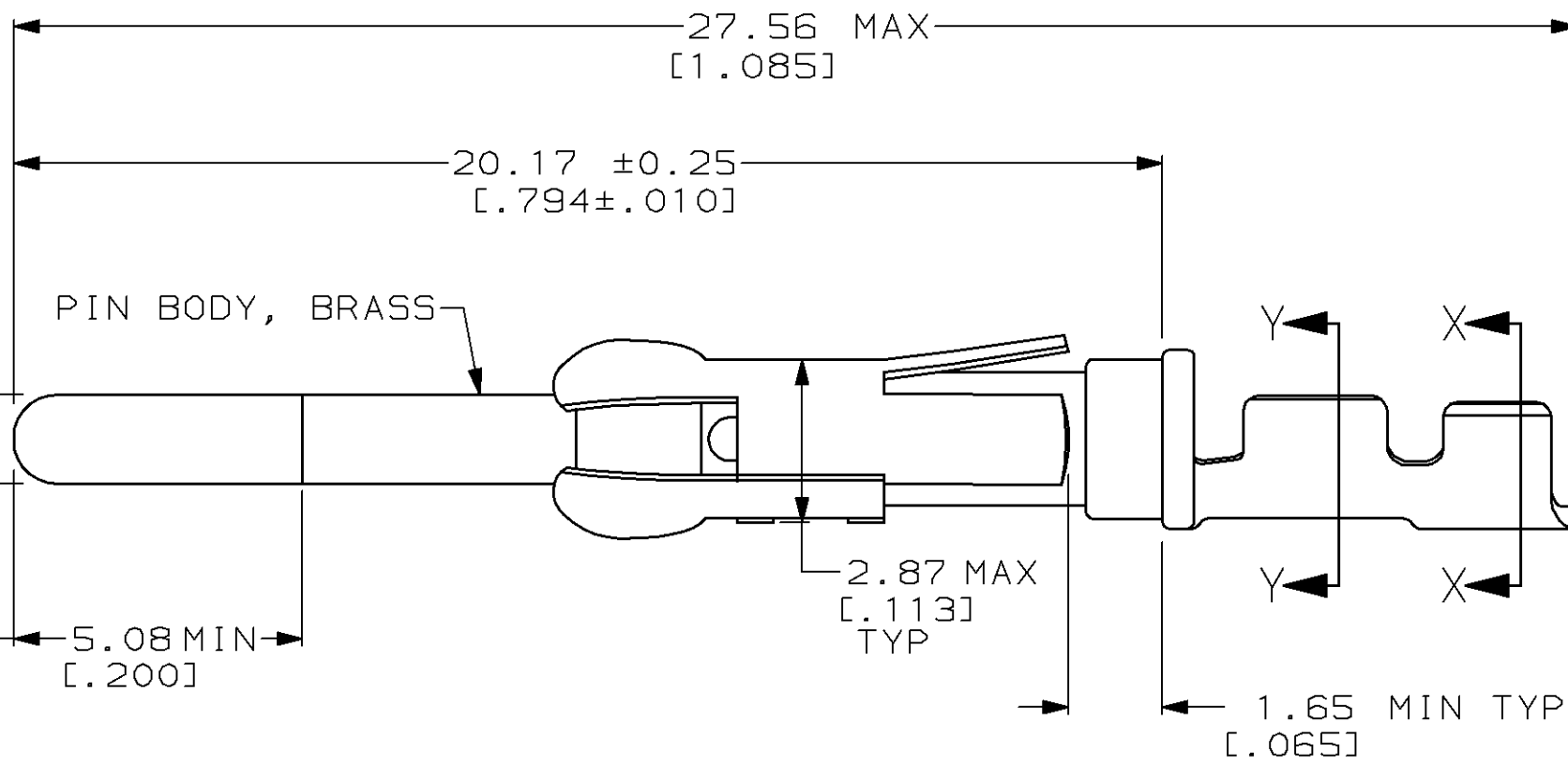
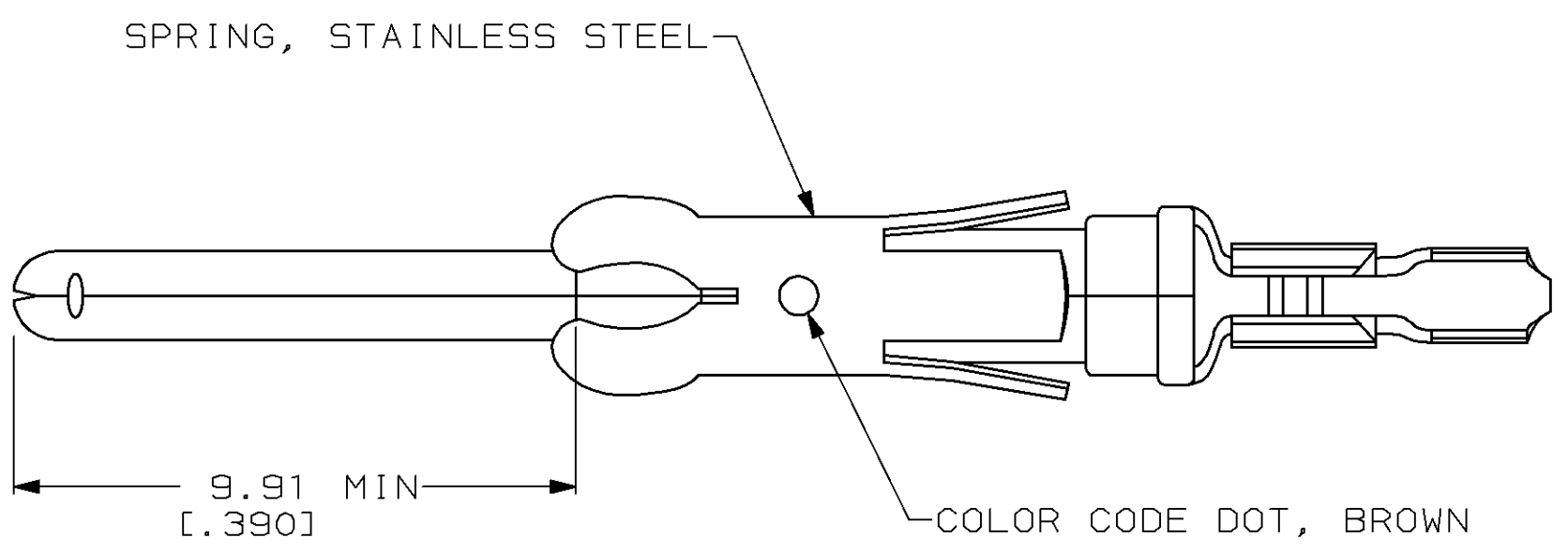

- 1 0.76µm [.000030] MIN GOLD IN LOCALIZED PLATE AREA, 0.25µm [.000010] MIN GOLD ON THE REMAINDER ALL OVER 1.27µm [.000050] MIN NICKEL.
- 2 0.76µm [.000030] MIN GOLD IN LOCALIZED PLATE AREA, GOLD FLASH ON THE REMAINDER ALL OVER 1.27µm [.000050] NICKEL.
- 3 0.38µm [.000015] MIN GOLD IN LOCALIZED PLATE AREA, GOLD FLASH ON THE REMAINDER ALL OVER 1.27µm [.000050] NICKEL.
- 4. WIRE RANGE 26-30 AWG.
- 5. INSULATION RANGE 1.02[.040]-1.52[.060] DIA.
- 6 0.38µm [.000015] MIN GOLD PER MIL-G-45204 IN LOCALIZED PLATE AREA, 1.27µm [.000050] MIN TIN-LEAD PER MIL-T-10727 FOR A LENGTH OF 5.69 [.224] MIN ON OPPOSITE END, BOTH OVER 1.27µm [.000050] MIN NICKEL PER QQ-N-290 ON ENTIRE CONTACT.

FINISH	STRIP P/N REF	PART NO
6	1-66425-1	66429-6
2	66425-4	66429-4
3	66425-3	66429-3
1	66425-1	66429-1

DO NOT SCALE PRINT. UNLESS SPECIFIED DIMENSIONS IN mm [INCHES] TOLERANCES ON: 2 PLC DEC ± 0.13[.005] 3 PLC DEC ± - ANGLES ± -		DR 9-27-90 H MOLL		AMP Incorporated Harrisburg, PA 17105-3608	
MATERIAL SEE CALL OUT		CHK 12-15-90 A. BOULLIANNE			
FINISH PIN BODY: SEE TABLE		APPD 5-1-91 R. WALTER		NAME PIN ASSEMBLY, LOOSE PIECE, TYPE III+	
-		APPD 5-1-91 R. WALTER		SIZE C 00779	
-		PRODUCT SPEC		DRAWING NO 66429	
-		APPLICATION SPEC		CAGE CODE 00779	
-		WEIGHT -		SCALE 8:1	
				SHEET 1 OF 1	