

6648167-1 Product Details



6648167-1

TE Internal Number: 6648167-1



High Current ELCON Drawer Connectors

 Always EU RoHS/ELV Compliant (Statement of Compliance)

Product Highlights:

- Connector
- Not Preloaded
- Connector Style = Receptacle
- Contact Size = 8, 12, 20
- Drawer Style = Middle

Documentation & Additional Information

Product Drawings:

- [SOCKET CONNECTOR HOUSING SUBASSEMBLY W/ SCREW MNT. F...](#) (PDF, English)

Catalog Pages/Data Sheets:

- [POWER_CONNECTORS_CATALOG_SEC02_CABLE_MOUNTED](#) (PDF, English)
- [AMP & ELCON Power Connector Layout Forms Datasheet 6...](#) (PDF, English)

Product Specifications:

- None Available

Application Specifications:

- [ELCON Drawer Series Connectors](#) (PDF, English)

Instruction Sheets:

- None Available

CAD Files: (CAD Format & Compression Information)

- [2D Drawing](#) (DXF, Version A)
- [3D Model](#) (IGES, Version A)
- [3D Model](#) (STEP, Version A)

Additional Information:

- [Product Line Information](#)

Related Products:

- [Tooling](#)

Product Features (Please use the Product Drawing for all design activity)

Product Type Features:

- Product Type = Connector

Electrical Characteristics:

- Current Rating (A) = 75

Body Features:

- Drawer Style = Middle
- Mount Type = Float

Contact Features:

- Contact Size = 8, 12, 20

Housing Features:

- Connector Style = Receptacle
- Housing Material = Thermoplastic - GF
- Housing Color = Black
- UL Flammability Rating = UL 94V-0

Configuration Features:

- Preloaded = No
- Type of Contact = Size 8 + Size 12 + Size 20

Industry Standards:

- [RoHS/ELV Compliance](#) = RoHS compliant, ELV compliant
- [Lead Free Solder Processes](#) = Not relevant for lead free process
- [RoHS/ELV Compliance History](#) = Always was RoHS compliant

Other:

- Brand = Elcon

THIS DRAWING IS UNPUBLISHED. RELEASED FOR PUBLICATION 20
 © COPYRIGHT 20 BY TYCO ELECTRONICS CORPORATION. ALL RIGHTS RESERVED.

LOC	DIST	REVISIONS			
P	LTR	DESCRIPTION	DATE	DWN	APVD
GP	00				
		C REV PER ECO-08-007334	26MAR2008	RG	SF

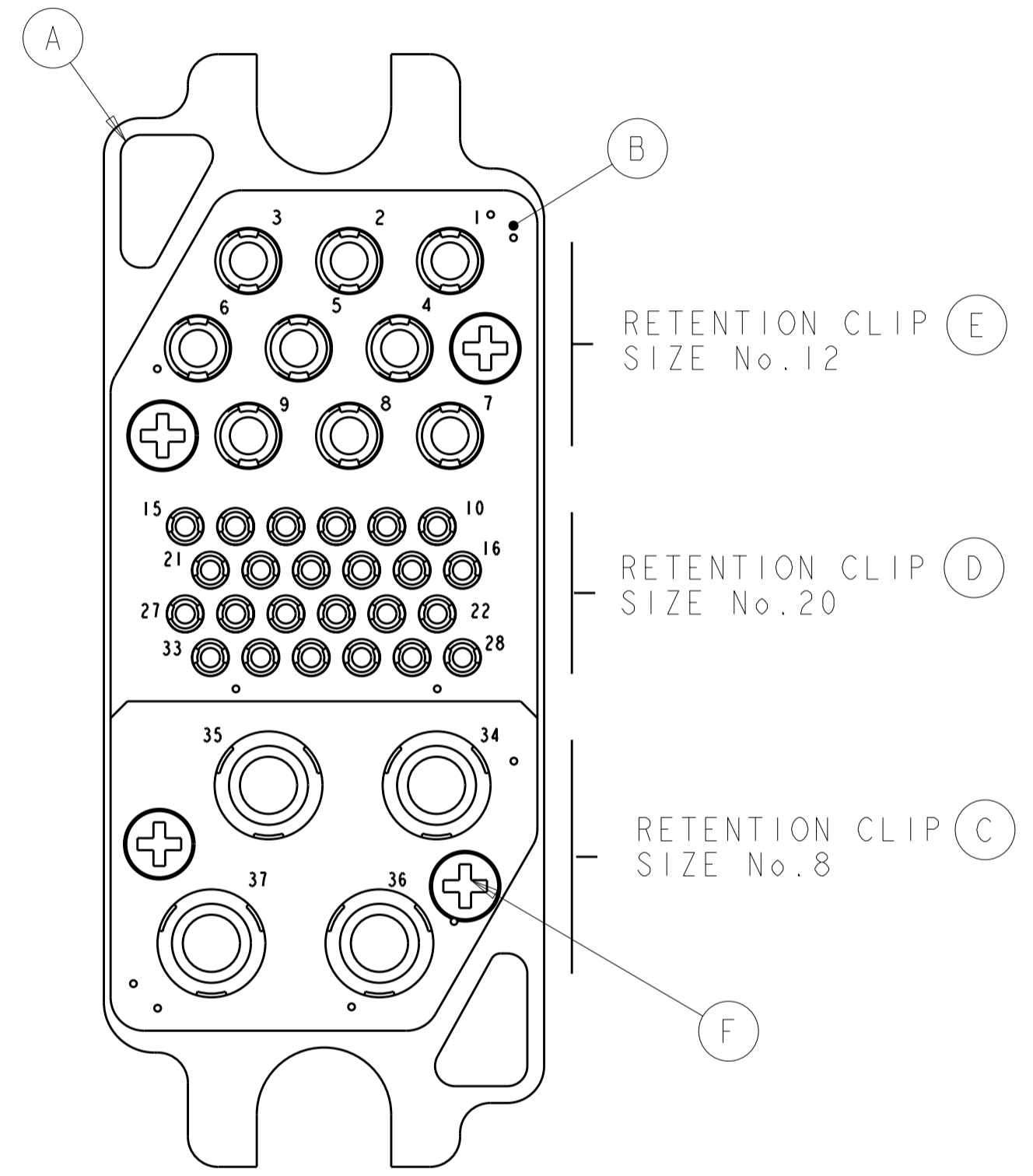
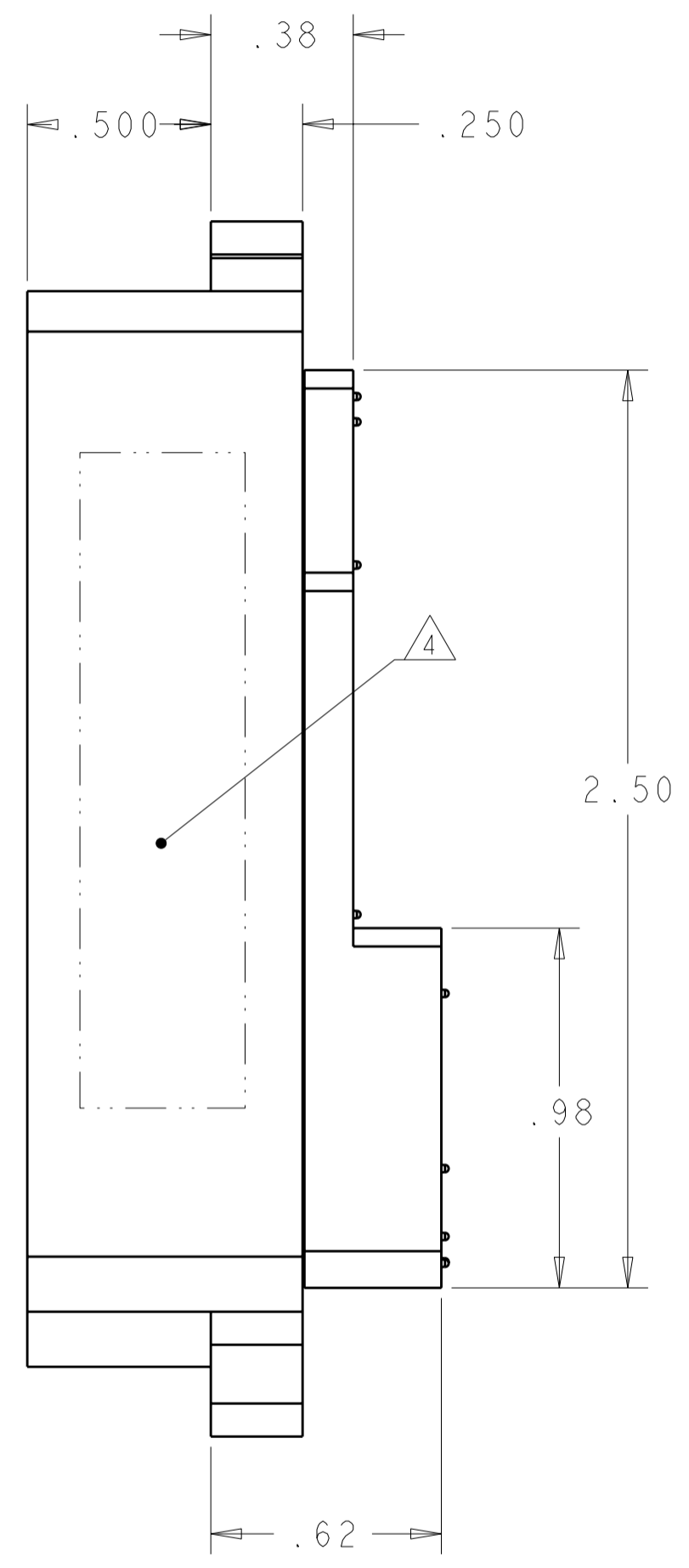
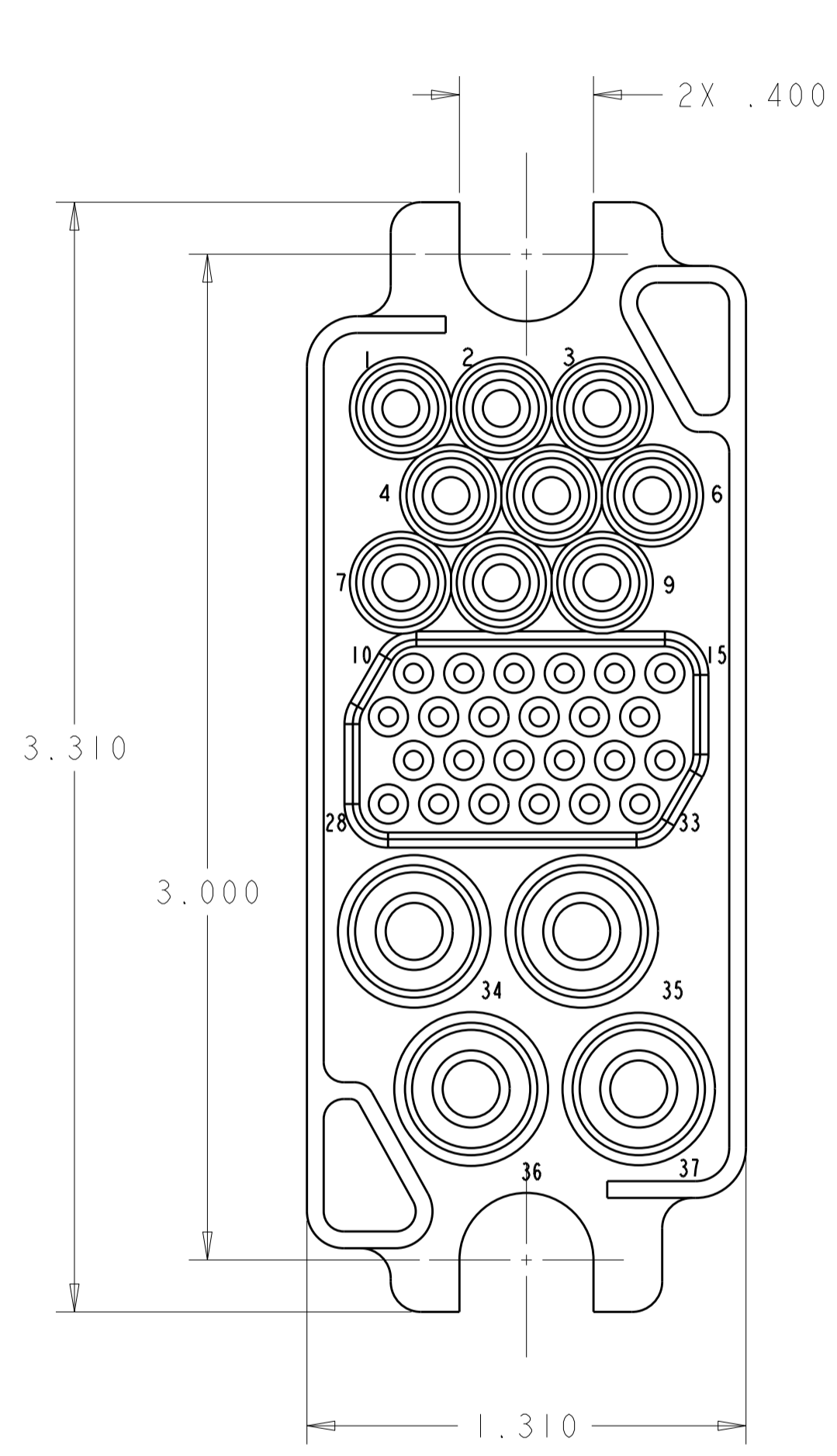

ELCON 75A MIDDLE DRAWER

THIS DRAWING IS A CONTROLLED DOCUMENT FOR TYCO ELECTRONICS CORPORATION. IT IS SUBJECT TO CHANGE AND THE CONTROLLING ENGINEERING ORGANIZATION SHOULD BE CONTACTED FOR THE LATEST REVISION.		DWN R. GRZYBOWSKI 26MAR2008	Tyco Electronics Harrisburg, PA 17105-3608	
DIMENSIONS: INCHES		CHK D. ORRIS 26MAR2008	NAME SOCKET CONNECTOR HOUSING SUBASSEMBLY W/ SCREW MNT. FLOAT MOUNT	
TOLERANCES UNLESS OTHERWISE SPECIFIED: 0 PLC ± 1 PLC ± 2 PLC ±.02 3 PLC ±.010 4 PLC ± ANGLES ±3 FINISH		APVD S. FLICKINGER 26MAR2008	SIZE A200779	DRAWING NO C-6648167
MATERIAL		PRODUCT SPEC -	RESTRICTED TO -	
		APPLICATION SPEC -	SCALE 3:1	SHEET 1 OF 2
		WEIGHT -	REV C	
		CUSTOMER DRAWING		

THIS DRAWING IS UNPUBLISHED. RELEASED FOR PUBLICATION 20
 © COPYRIGHT 20 BY TYCO ELECTRONICS CORPORATION. ALL RIGHTS RESERVED.

LOC	DIST	REVISIONS			
P	LTR	DESCRIPTION	DATE	DWN	APVD
GP	00	-	SEE SHEET 1	-	-

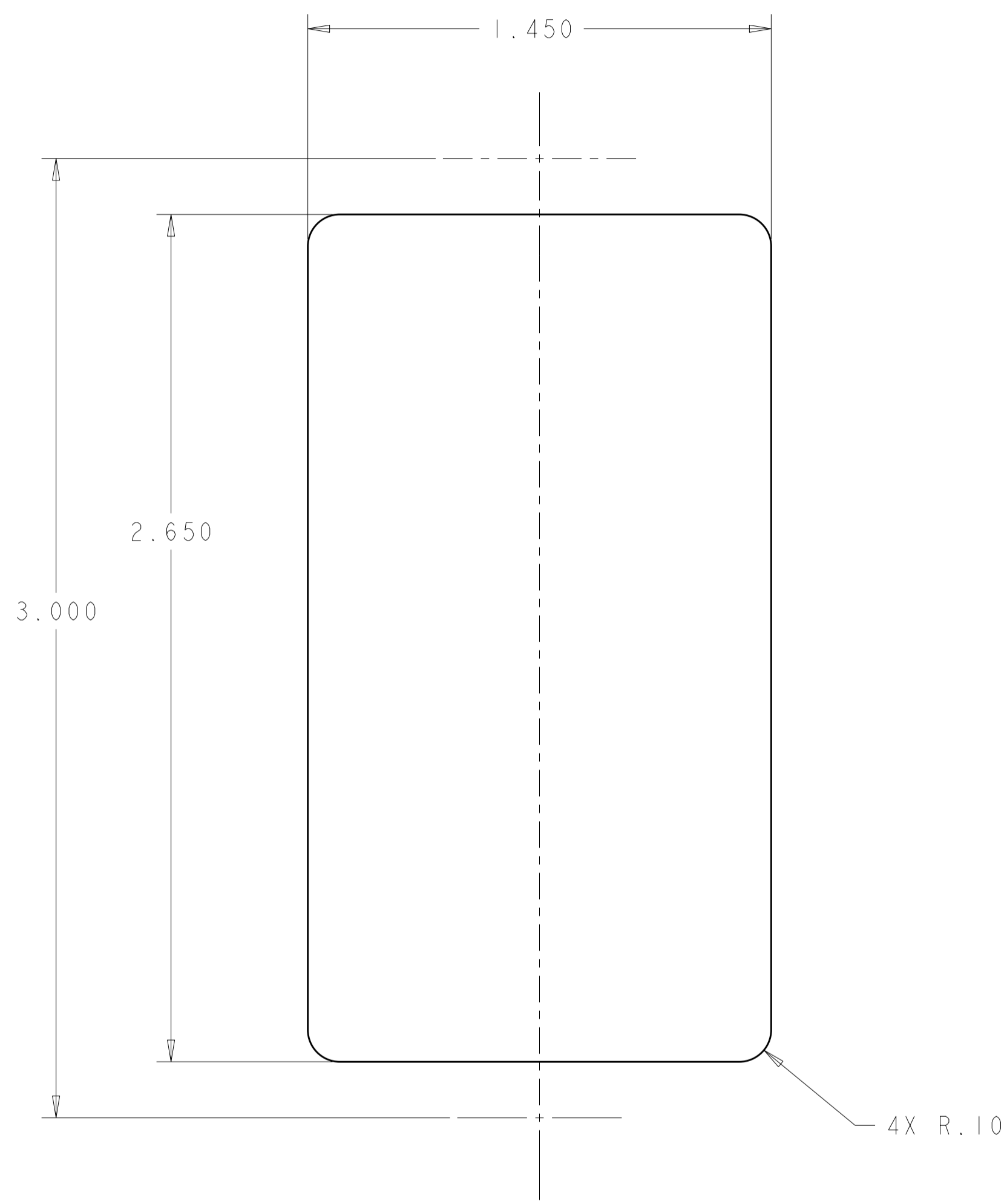

RECOMMENDED PANEL CUTOUT
 AS VIEWED FROM CONNECTOR MOUNTING SIDE

- PART NUMBER CHANGES AND/OR DESIGN CHANGES AFFECTING ITEM INTERCHANGEABILITY REQUIRE TYCO ELECTRONICS APPROVAL AND AUTHORIZATION BY REVISION TO THIS DRAWING.
- MATERIAL:
 INSULATOR: THERMOPLASTIC, GLASS REINFORCED, UL94V-0
 FLAMMABILITY RATED, COLOR - BLACK
 RETENTION CLIP - BERYLLIUM COPPER OR STAINLESS STEEL
- RETENTION CLIPS INSTALLED IN THE CONNECTOR ASSEMBLY.
- ITEMS PROVIDED TO THIS SPECIFICATION TO BE PERMANENTLY IDENTIFIED PER THE FOLLOWING IDENTIFIER:

YEAR 1 WEEK 1
 TYCO ELECTRONICS P/N DATE CODE (e.g. 0608)
 XXXXXXXX-X XXXX

THIS DRAWING IS A CONTROLLED DOCUMENT FOR TYCO ELECTRONICS CORPORATION. IT IS SUBJECT TO CHANGE AND THE CONTROLLING ENGINEERING ORGANIZATION SHOULD BE CONTACTED FOR THE LATEST REVISION.		DWN R. GRZYBOWSKI 26MAR2008	Tyco Electronics Harrisburg, PA 17105-3608	
DIMENSIONS: INCHES		CHK D. ORRIS 26MAR2008	NAME SOCKET CONNECTOR HOUSING SUBASSEMBLY W/ SCREW MNT. FLOAT MOUNT	
TOLERANCES UNLESS OTHERWISE SPECIFIED: 0 PLC ± 1 PLC ± 2 PLC ±.02 3 PLC ±.010 4 PLC ± ANGLES ±3 FINISH		APVD S. FLICKINGER 26MAR2008	PRODUCT SPEC -	RESTRICTED TO -
MATERIAL -		APPLICATION SPEC -	WEIGHT -	SIZE A200779
-		CUSTOMER DRAWING	DRAWING NO. C-6648167	SCALE 3:1 SHEET 2 OF 2 REV C