

Distributed by:

JAMECO[®]
ELECTRONICS

www.Jameco.com ♦ 1-800-831-4242

The content and copyrights of the attached
material are the property of its owner.

Jameco Part Number 223247

LOC	DIST	REVISIONS				
GP	00	REV	DESCRIPTION	DATE	OWN	APPV
		D	REDRAWN ON CAD PER EC 0420-141-96	18 SEPT 97	TS	SB
		E	REV PER 0640-292-98	01 SEP 98	PB	JK
		F	REV PER EC 0640-102-99	01 MAR 99	DB	JK
		G	REV PER EC 0640-0002-01	10 JAN 02	JR	JG

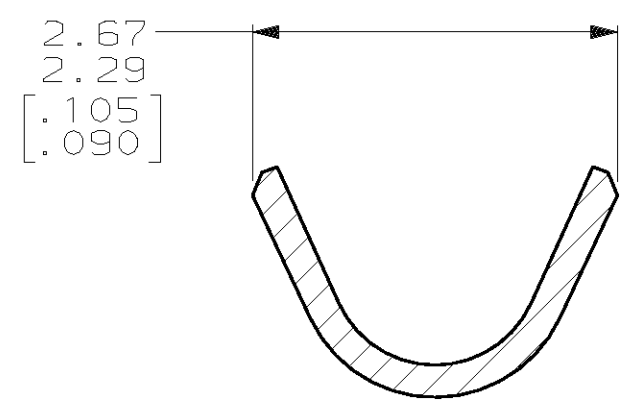
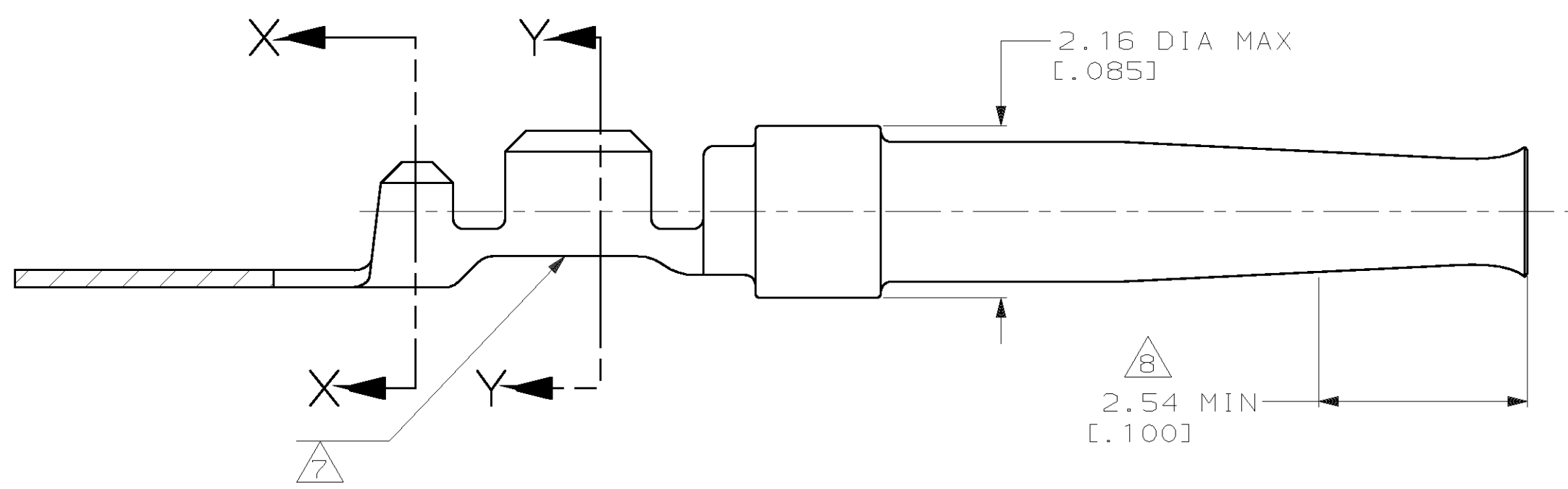
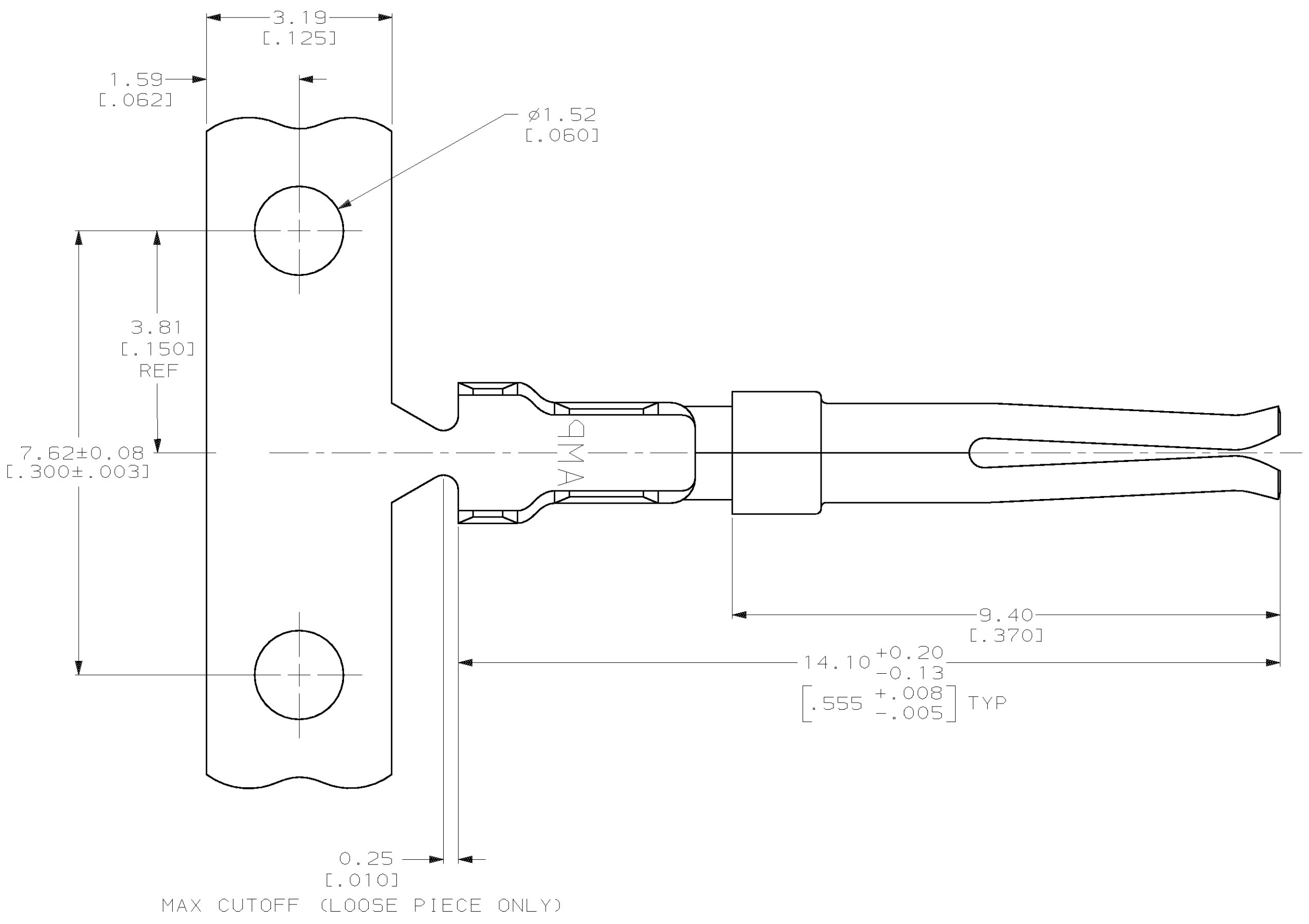

SECTION X-X
INSULATION BARREL
SCALE 20:1

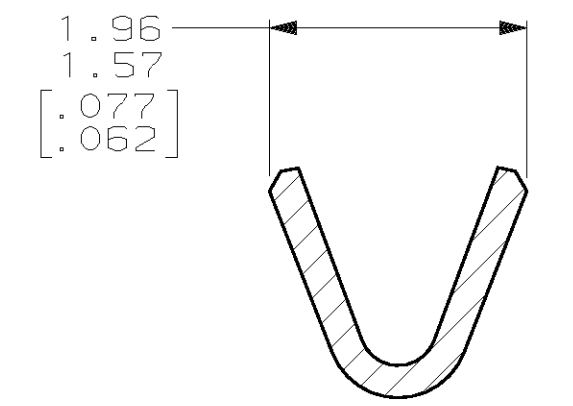

SECTION Y-Y
WIRE BARREL
SCALE 20:1

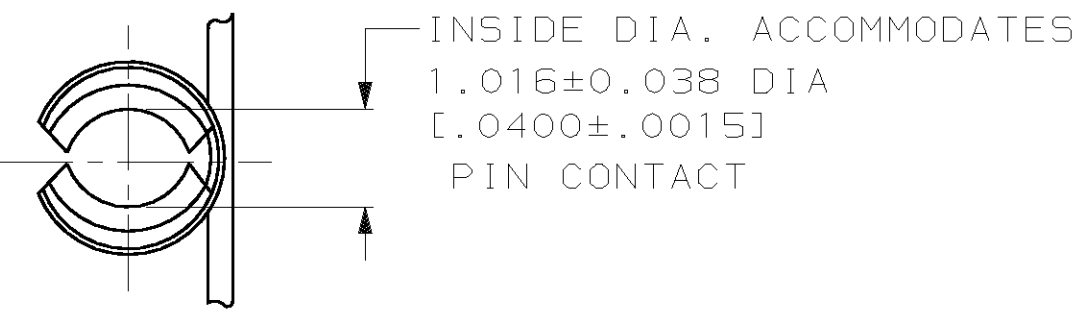

- 1. FOR MINI-APPLICATOR CRIMPING.
- 2. WIRE RANGE IS 22-26 AWG AND INSULATION RANGE IS 1.02/1.27 [0.040/.050].
- 3. 0.76µm [0.000030] GOLD PER MIL-G-45204 ON MATING END FOR A LENGTH OF 2.54µm [0.100] MIN., GOLD FLASH PER MIL-G-45204 ON REMAINDER, ALL OVER 1.27µm [0.000050] NICKEL PER QQ-N-290.
- 4. GOLD FLASH PER MIL-G-45204 OVER 0.76µm [0.000030] NICKEL PER QQ-N-290.
- 5. 0.025µm [0.000001] MIN GOLD PER MIL-G-45204 ON MATING END FOR A LENGTH OF 2.54 [0.100] MIN., TIN PLATED WIRE BARRELS, ALL OVER 0.76µm [0.000030] NICKEL PER QQ-N-290.
- 6. SELECTIVE GOLD PLATED 0.76µm [0.000030] THICK PER MIL-G-45204 ON MATING END FOR A LENGTH OF 2.54 [0.100] MIN., TIN PLATED WIRE BARRELS, ALL OVER 1.27µm [0.000050] NICKEL PER QQ-N-290.
- 7. COLOR CODE YELLOW IN THIS AREA INDICATES 22-26 AWG WIRE RANGE. ONLY LOOSE PIECE PART NUMBERS ARE COLOR CODED.
- 8. LOCALIZED GOLD PLATE AREA - INSIDE SURFACE FOR GOLD AND NICKEL PLATING NOTES 3 AND 6. OUTSIDE SURFACES FOR ALL OTHER PLATING NOTES.
- 9. GOLD PLATING MAY NOT APPEAR ON CARRIER STRIP.

STANDARD	FINISH	TYPE	PART NUMBER
STANDARD	6	LOOSE PIECE	1-745253-6
STANDARD	6	STRIP	1-745253-4
OBSELETE	5	LOOSE PIECE	1-745253-3
STANDARD	5	STRIP	1-745253-1
STANDARD	4	LOOSE PIECE	745253-7
STANDARD	3	LOOSE PIECE	745253-6
STANDARD	4	STRIP	745253-3
STANDARD	3	STRIP	745253-2

THIS DRAWING IS A CONTROLLED DOCUMENT.

DIMENSIONS mm (INCHES)	TOLERANCES UNLESS OTHERWISE SPECIFIED.	DWN S. WELDON 11-3-80	AMP Incorporated Harrisburg, PA 17105-3608
0 PLC ±0.013	1 PLC ±0.013	CHK J. GERACE 11-5-80	AMP SOCKET CONTACT, SIZE 20 DF, 22-26 AWG, W/.040-.050 DIA INSULATION SUPPORT
2 PLC ±0.013 [0.005]	3 PLC ±0.013	APPV R. BAER 11-10-80	
4 PLC ±0.013	ANGLES ±0.25°	PRODUCT SPEC 108-40005	SIZE A1
MATERIAL PHOS. BRONZE PER 00-B-750	FINISH SEE TABLE	APPLICATION SPEC 114-10000	WEIGHT -
CUSTOMER DRAWING		SCALE 15:1	SHEET 1 OF 1