

Distributed by:

JAMECO[®]
ELECTRONICS

www.Jameco.com ♦ 1-800-831-4242

The content and copyrights of the attached
material are the property of its owner.

Jameco Part Number 862073

THIS DRAWING IS UNPUBLISHED. RELEASED FOR PUBLICATION, 19 .
 © COPYRIGHT 19 BY AMP INCORPORATED. ALL INTERNATIONAL RIGHTS RESERVED.

LOC		D15T		REVISIONS				DATE	APPD
GP	00	P	F	ZONE	LTR	DESCRIPTION			
					H	REVISED PER EC 0513-0437-02	16JAN03	JG	

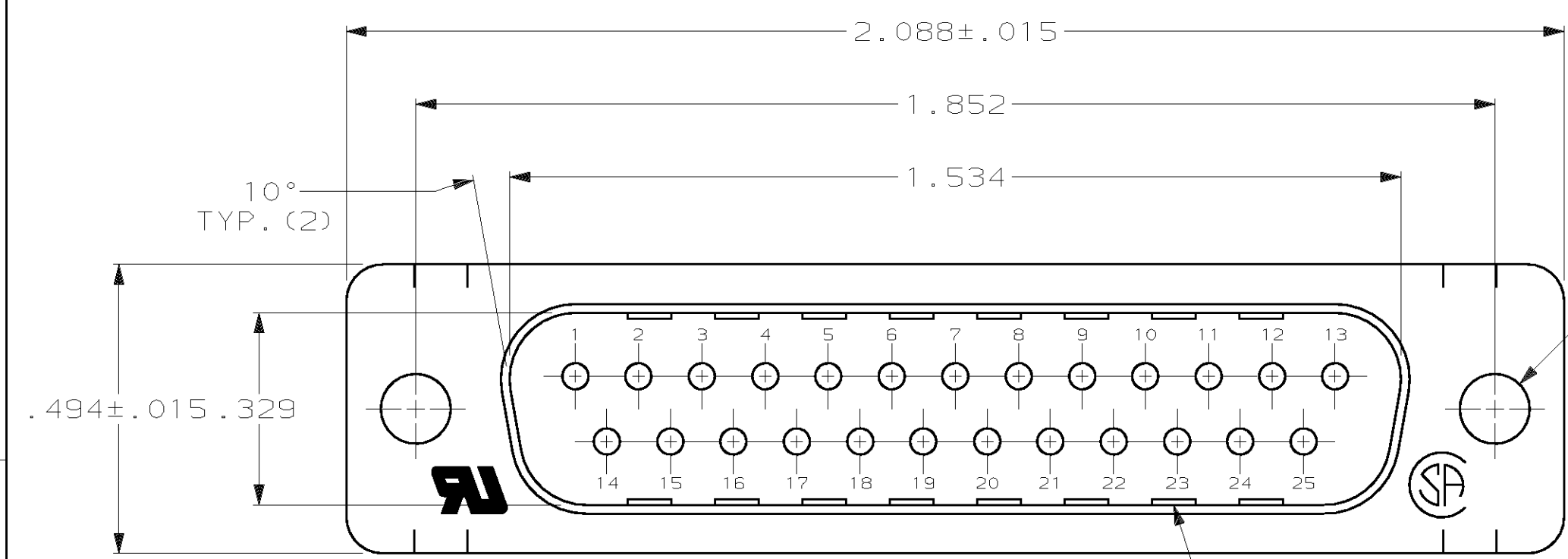

- CONNECTOR MATES WITH ANY 25 POS. RECEPTACLE IN AMPLIMITE SERIES & COMPLIES WITH AMP SPEC. 108-40,005 WHERE APPLICABLE.
- FLAME RETARDANT 94V-0 RATED THERMOPLASTIC; COLOR: BLACK.
- STEEL PER QQ-S-698.
- BRASS PER MIL-C-50.
- TIN PLATING PER MIL-T-10727, GOLD PLATING PER MIL-G-45204, NICKEL PLATING PER QQ-N-290.
- TIN PLATED.
- GOLD FLASH ON MATING END, $.000100$ MIN TIN-LEAD ON SOLDER END, ALL OVER $.000050$ MIN NICKEL.
- GOLD PLATED FOR LENGTH OF $.150$ MIN FROM MATING END, $.000030$ MIN GOLD IN MATED AREA, $.000100$ MIN TIN-LEAD ON SOLDER END, ALL OVER $.000050$ MIN NICKEL.

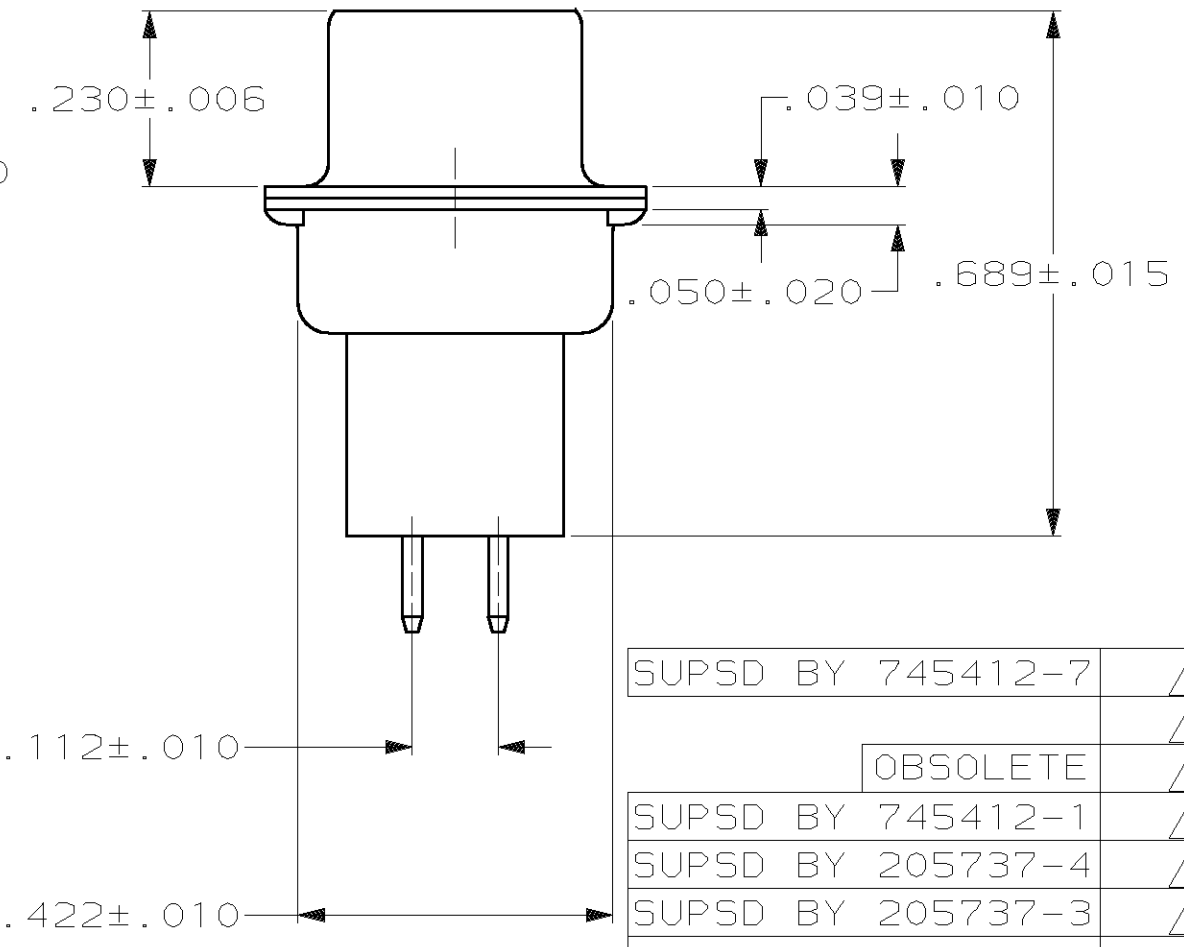
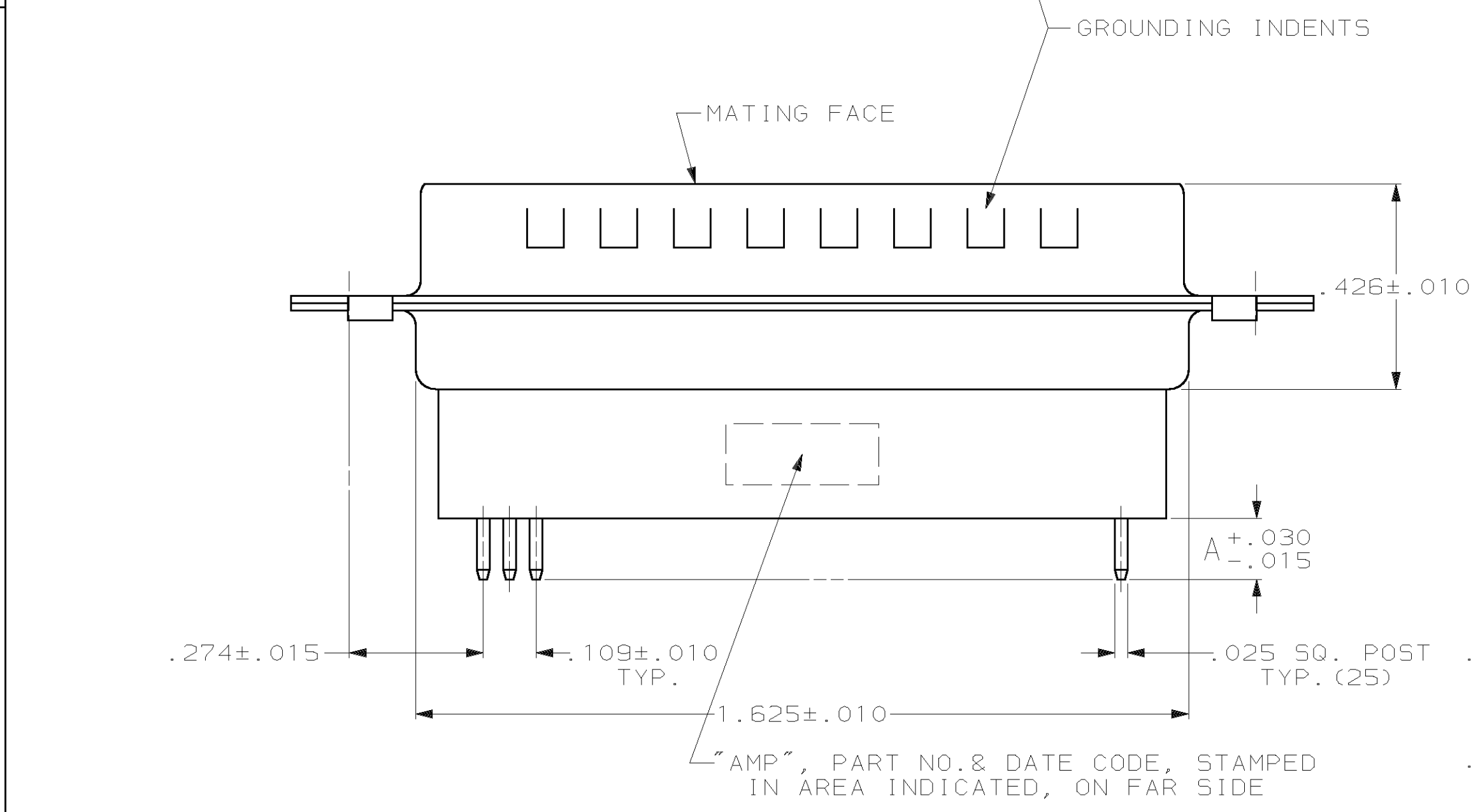

SUPSD BY	CONTACT FINISH	SIZE	PART NUMBER
745412-7	7	.188	745412-8
	8	.188	745412-7
OBSOLETE	7	.651	745412-6
SUPSD BY 745412-1	8	.651	745412-5
SUPSD BY 205737-4	7	.427	745412-4
SUPSD BY 205737-3	8	.427	745412-3
SUPSD BY 745412-1	7	.125	745412-2
	8	.125	745412-1

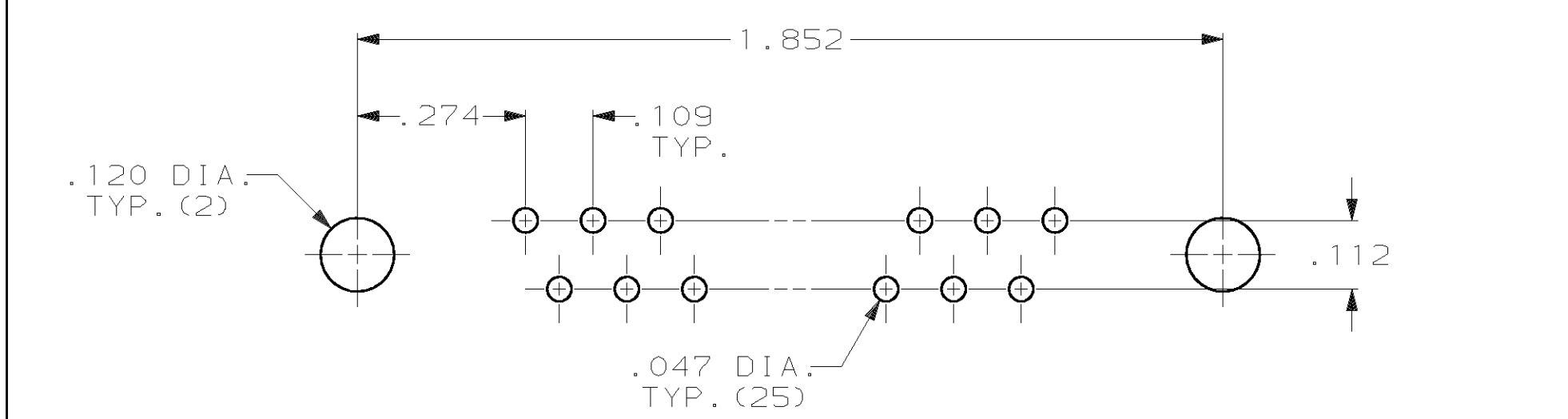

DO NOT SCALE PRINT. UNLESS SPECIFIED DIMENSIONS IN INCHES TOLERANCES ON:		DR 10-25-83 J.GERACE		AMP AMP Incorporated Harrisburg, PA 17105-3608	
2 PLC DEC \pm	$\pm .005$	CHK 10-25-83 J.GERACE		NAME	
3 PLC DEC \pm	$\pm .005$	APPD 01-04-84 B.TAYLOR		PLUG ASSEMBLY, SIZE 3, 25 POSN, VERTICAL, .025 SQ. POSTS, W/ GROUNDING INDENTS, AMPLIMITE™ HDP	
ANGLES \pm	$\pm 2^\circ$	APPD 01-04-84 J.ASSINI		SIZE	CAGE CODE
MATERIAL MOLDED PARTS: 2		PRODUCT SPEC -		C	00779
SHELLS: 3		APPLICATION SPEC -		SCALE	-
CONTACTS: 4		WEIGHT -		DRAWING NO	C=745412
FINISH 5				SHEET	1 OF 1
SHELLS: 6					
CONTACTS: SEE TABLE					

THIS DRAWING IS A CONTROLLED DOCUMENT FOR AMP INCORPORATED. IT IS SUBJECT TO CHANGE AND THE CONTROLLING ENGINEERING ORGANIZATION SHOULD BE CONTACTED FOR THE LATEST REVISION.