

LOC		DIST		REVISIONS			
F	LTR	DESCRIPTION	DATE	DMN	APVD		
B		REVISED PER ECO-08-004975	3MAR08	JDP	CWR		

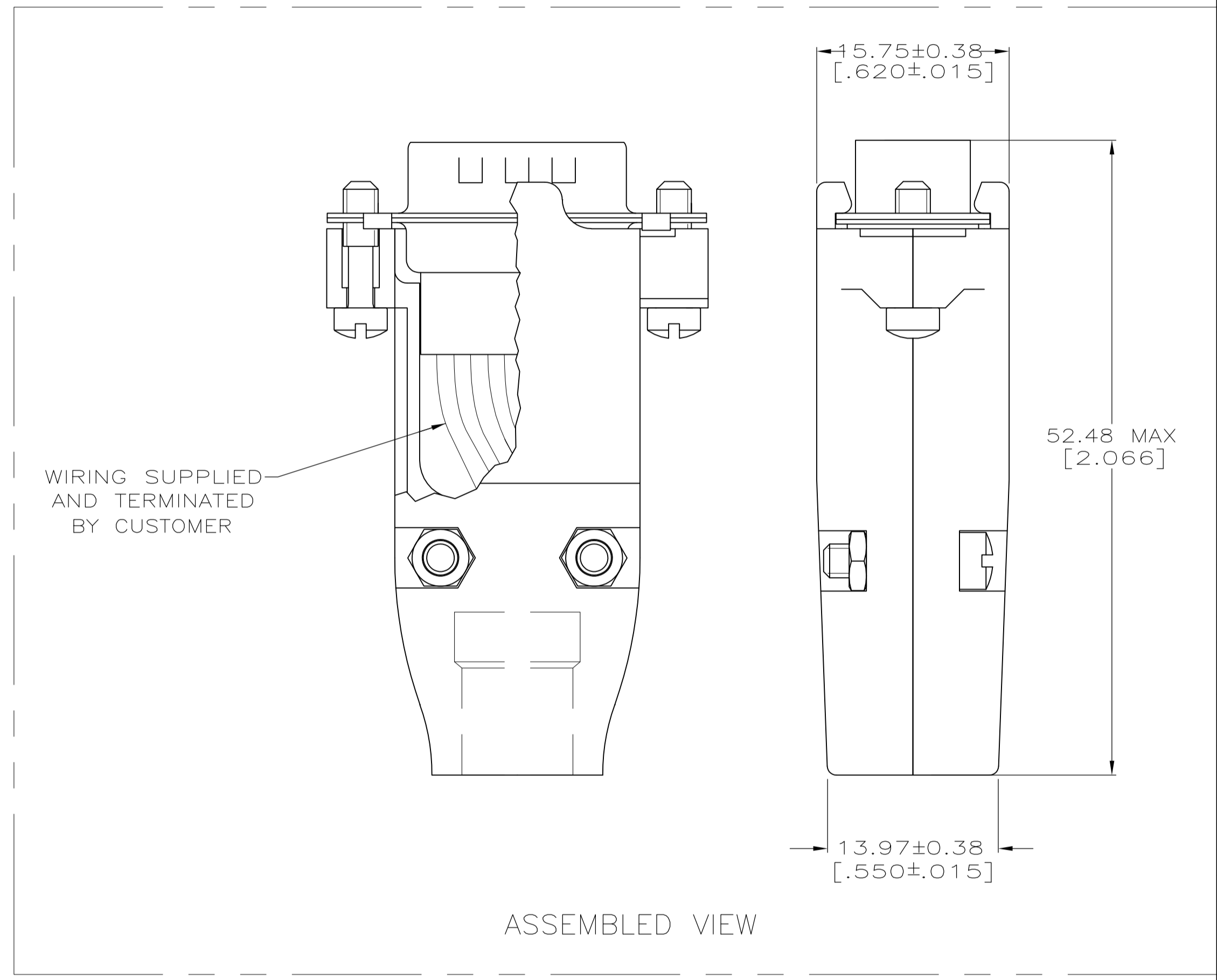

1. CONTACTS ACCEPT 24-20 AWG RANGE.
2. INSERTS: NYLON, GLASS FILLED, UL 94V-0 RATED, BLACK.
3. GROMMETTS: PVC, UL 94V-0 RATED, BLACK.
4. CONTACTS: BRASS.
5. SHELLS: CARBON STEEL.
6. CABLE CLAMPS: ZINC; SCREWS & NUTS: CARBON STEEL.
7. CONTACTS: GOLD FLASH FOR A LENGTH OF 3.81[.150] MIN FROM MATING END, 2.54µm[.000100] MIN TIN ON OPPOSITE END FOR A LENGTH OF 4.06 [.160] MIN FROM END OF INSULATION BARREL, BOTH OVER 0.76µm[.000030] MIN NICKEL ON ENTIRE CONTACT.
8. SHELLS: 5.08µm[.000200] MIN TIN OVER 2.54µm[.000100] MIN COPPER.
9. MOUNTING SCREWS & NUTS: 3.81µm[.000150] MIN ZINC, CLEAR CHROMATE COATED; FILISTER HEAD SCREWS: ZINC, CLEAR CHROMATE COATED.
10. CABLE CLAMP: NICKEL OVER COPPER.

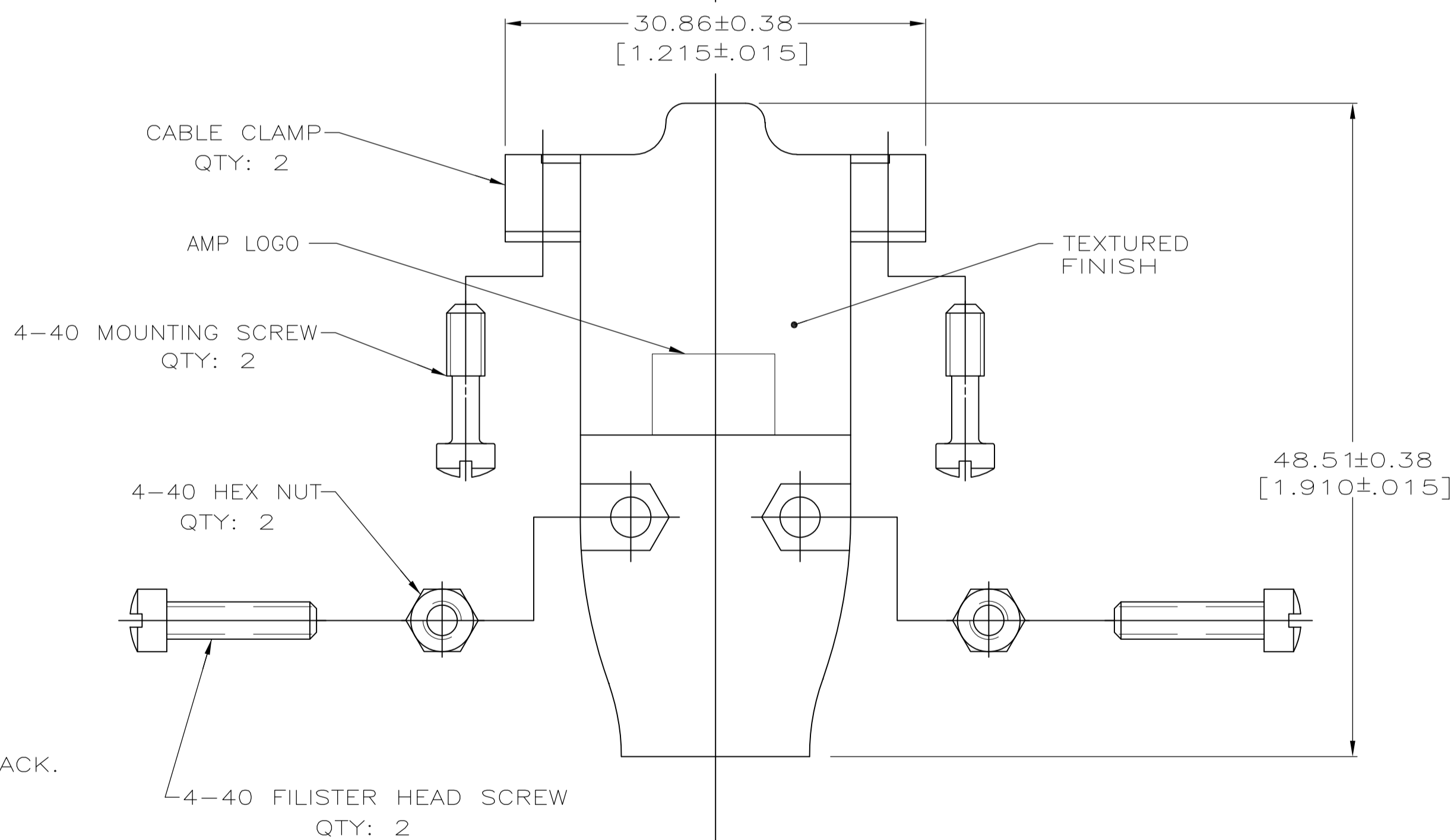
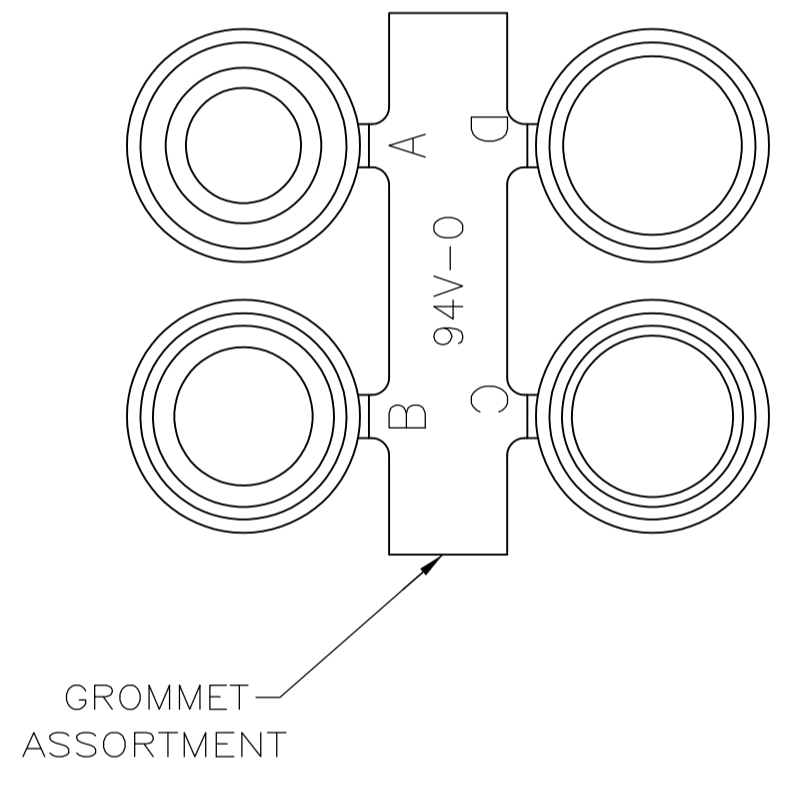
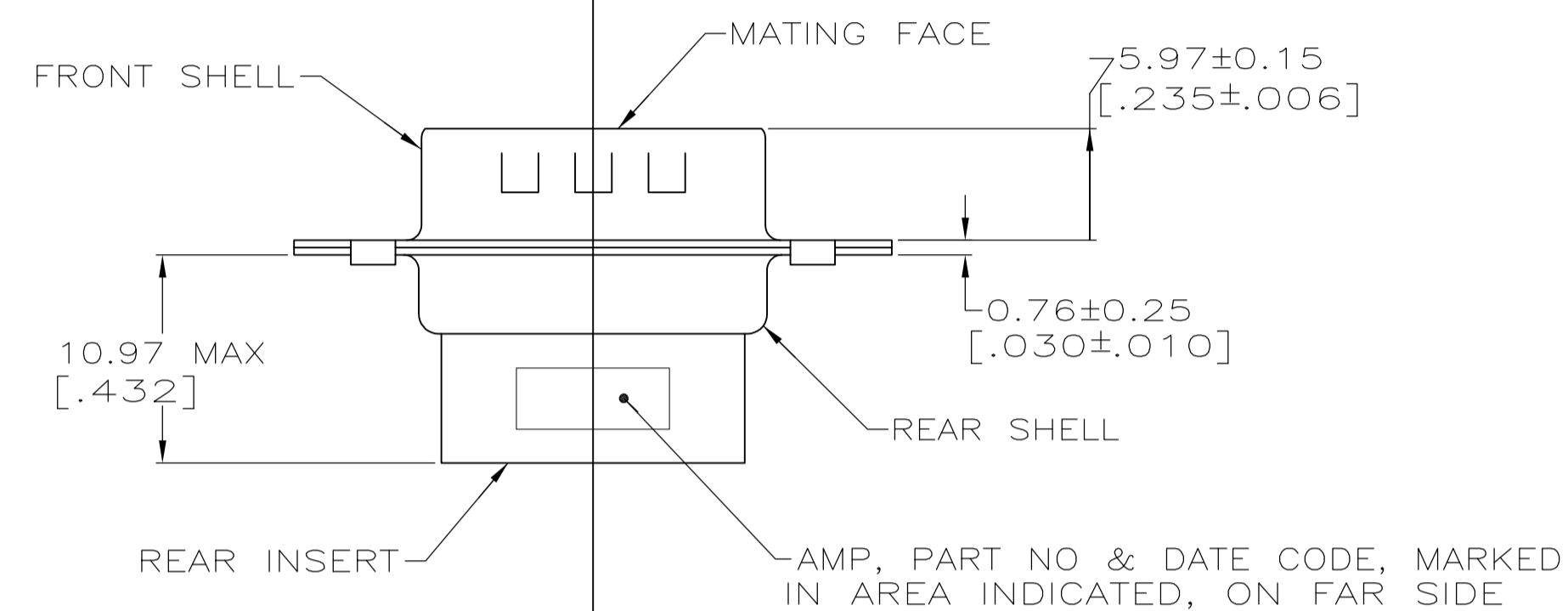
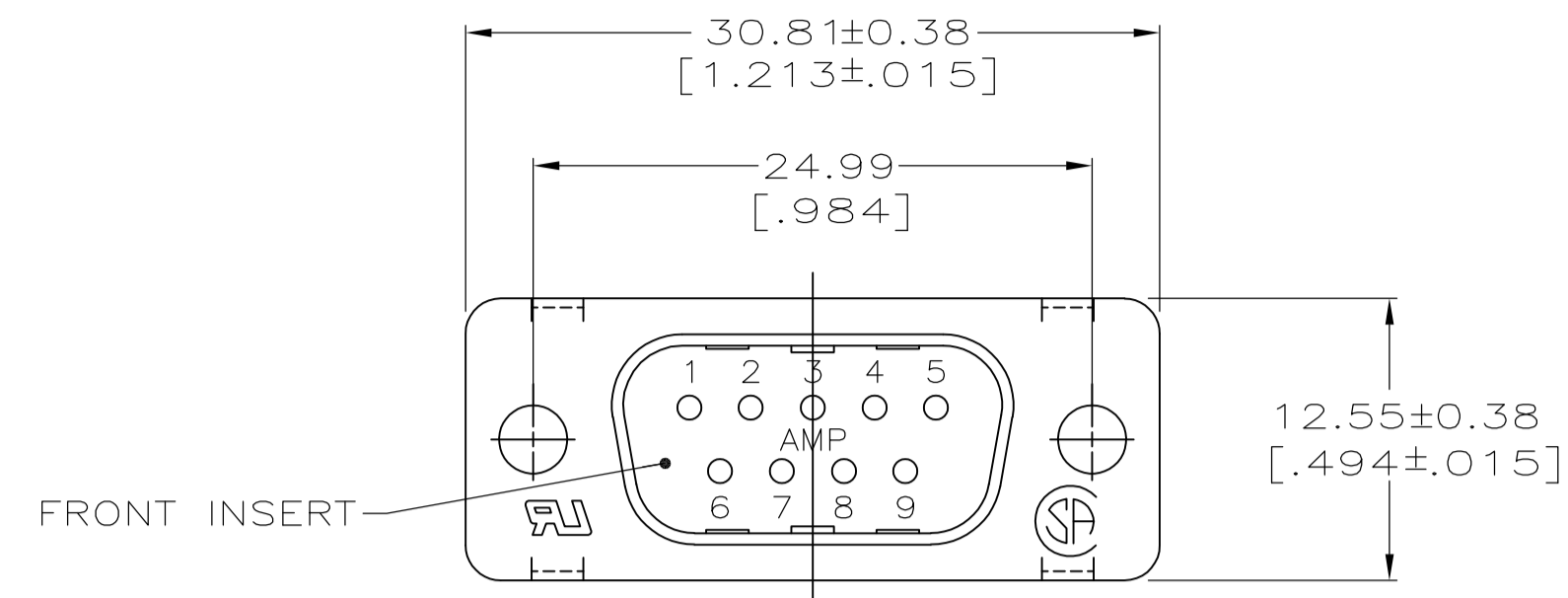
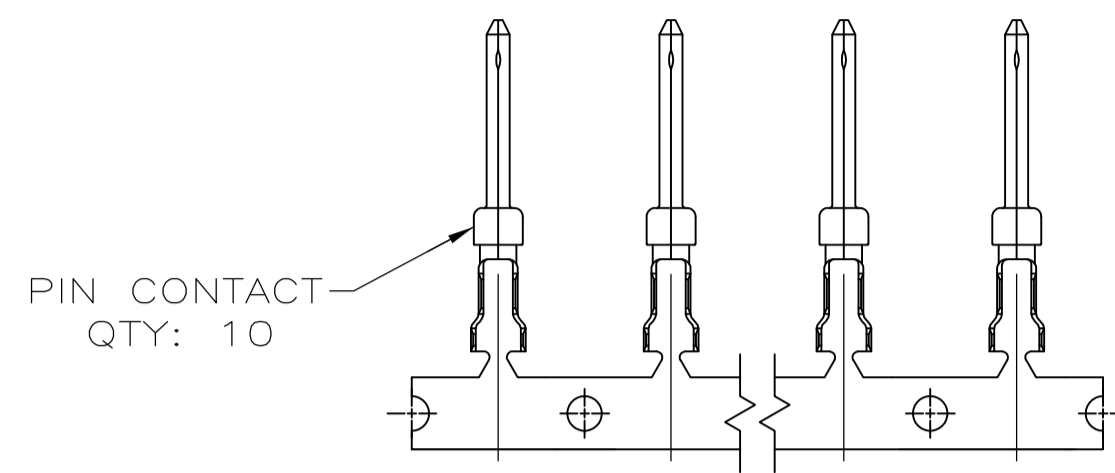
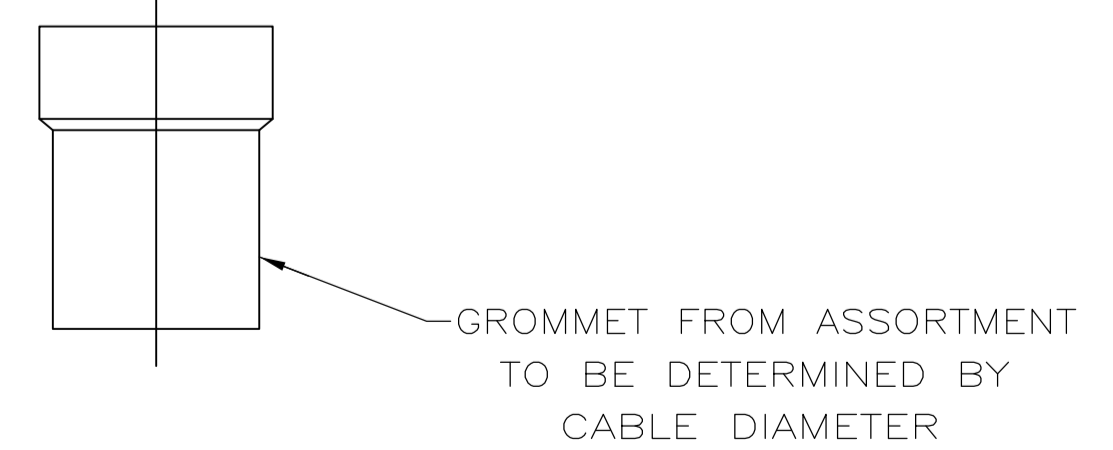

749805-7
PART NO

THIS DRAWING IS A CONTROLLED DOCUMENT.		DIN J. REITZEL 1AUG03	Tyco Electronics Corporation Harrisburg, PA 17105-3608	
DIMENSIONS: mm [INCHES]		CHK S. BOLASH 1AUG03	NAME PLUG KIT, UNASSEMBLED, SIZE 1, 9 POSN _M METAL SHELL, AMPLIMITE, HDP-20	
TOLERANCES UNLESS OTHERWISE SPECIFIED:		APP'D M. WAMSLEY 1AUG03	PRODUCT SPEC 108-40005	
0. PLC ± -		APPLICATION SPEC 114-40030		
1. PLC ± -		SIZE A1		
2. PLC ± 0.13[.005]		CAGE CODE DRAWING NO 00779		
3. PLC ± -		DIN 749805-7		
4. PLC ± -		WEIGHT -		
ANGLES ± -		CUSTOMER DRAWING		
MATERIAL		SCALE 2:1		
FINISH		SHEET 1 OF 1		
RESTRICTED TO		REV B		