

REVISIONS					
P	LR	DESCRIPTION	DATE	DWN	APVD
E1		REVISED PER ECO-17-009556	03JUL2017	RS	SW

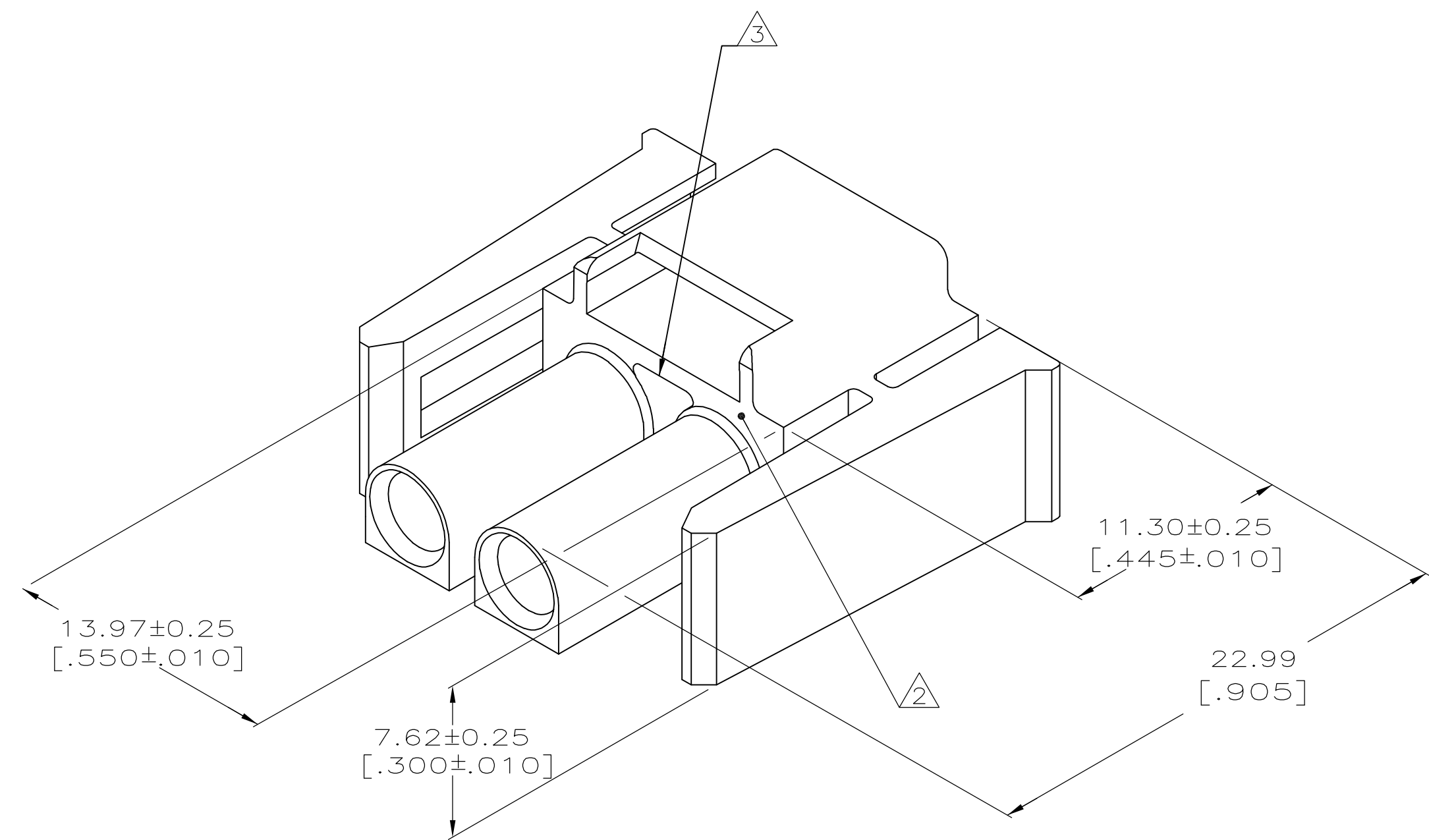

- MUST BE ASSEMBLED WITH PLUG REAR P/N 770032-1 BEFORE MATING. KIT P/N IS 770017-1.
- AMP LOGO LOCATED THIS SURFACE.
- NEW MOLD CONSTRUCTION PROVIDES MATERIAL REDUCTION CORING AT BASE OF SILOS WITH NO CORING AS OPTIONAL.
- DIMENSIONS SHOWN REPRESENT PRODUCT IN DRY, AS MOLDED CONDITION. ADDITIONAL 2% GROWTH DUE TO SUBSEQUENT MOISTURE ABSORPTION MAY OCCUR AND SHOULD BE ACCOUNTED FOR

770031-1
PART NUMBER

METRIC

THIS DRAWING IS A CONTROLLED DOCUMENT.		DWN K. SALMON 1-15-92	TE Connectivity	
DIMENSIONS: INCHES		CHK R. SWING 1-15-92	NAME PLUG FRONT, 2 CIRCUIT, UNIVERSAL MATE-N-LOK	
TOLERANCES UNLESS OTHERWISE SPECIFIED:		APVD	PRODUCT SPEC	
0 PLG ± -			APPLICATION SPEC	
1 PLG ± -				
2 PLG ± -				
3 PLG ± 0.13 [.005]				
4 PLG ± -				
ANGLES ± -				
FINISH -				
MATERIAL NYLON,UL94V-0,	WEIGHT 0.000000	SIZE A1	CAGE CODE 00779	DRAWING NO 770031
CUSTOMER DRAWING		SCALE 5:1	SHEET 1 OF 1	REV E1