

Distributed by:

**JAMECO**<sup>®</sup>  
ELECTRONICS

**www.Jameco.com ♦ 1-800-831-4242**

The content and copyrights of the attached  
material are the property of its owner.

Jameco Part Number 1977500

## AMPSEAL Automotive Plug Connector and Header Assembly

### Product Facts

- Sealing of both interface and wires provides for environmental integrity
- Secondary contact locking and lanceless contacts ensure positive contact seating, without backout
- High-temperature materials withstand underhood environment and surface mount applications
- Lanceless receptacle contacts reduce tangling during storage and handling
- Integral latches firmly hold mated connector halves together without additional hardware
- Contacts accept 20 to 16 AWG wire with insulation diameter of 1.7 - 2.7 mm [.067 - .106 in.]
- Designed to comply to ISO-8092-2 Test Standard
- Keying and color coding
- Available in 23 position and 35 position right angle or vertical headers
- 8 position and 14 position to be released in late 1998
- Temperature range  
Gold pins +125° C  
Tin lead +105° C  
-40° C
- Available in tin-lead or gold
- Current rating up to 17 amps
- Recognized under the Component Program of Underwriters Laboratories Inc., File No. E28476

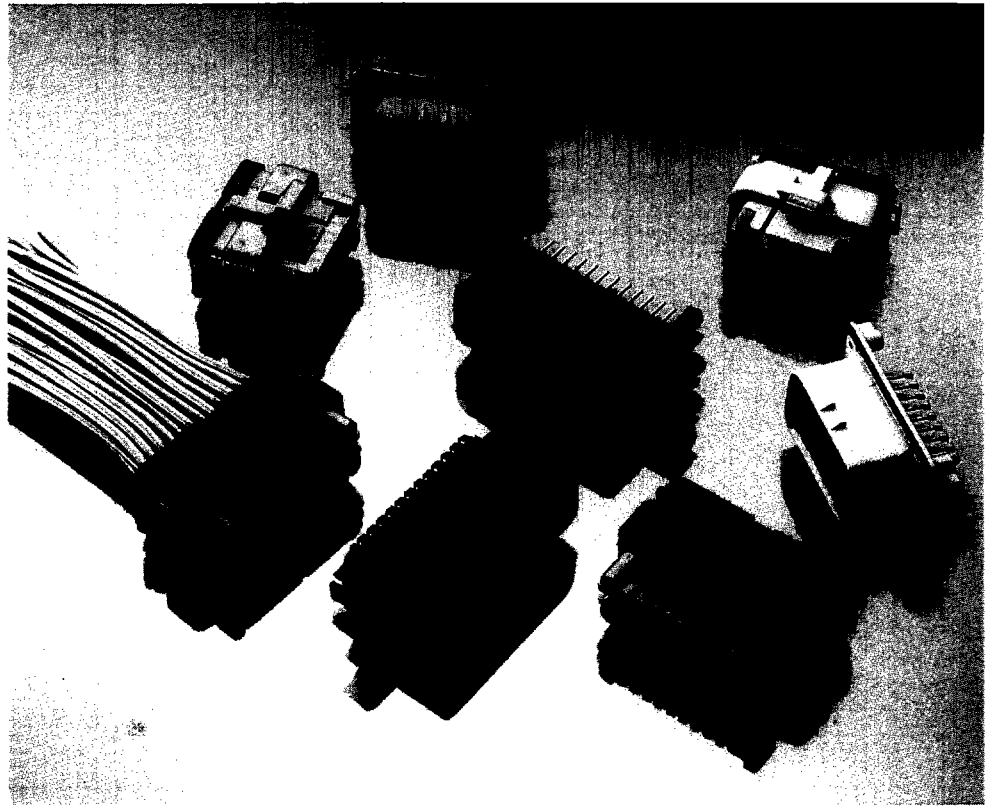

AMPSEAL automotive connectors provide rugged reliability, easy use, and superior environmental sealing. They are available in cable plugs and pc board-mounting headers that are designed to stand up to high-temperature underhood applications.

The preassembled plug connector features built-in contact sealing to eliminate individual wire-sealing grommets, while an integral interfacial seal protects mated connectors. All circuits are sealed by a diaphragm in the rubber wire seal. When the connector is assembled, the diaphragm is pierced as the contact passes through it. Unused circuit cavities remain sealed.

The housing uses a two-piece contact-holding design that provides secondary locking which protects against contact backout. After contacts are inserted into the housing, the housing snaps shut to firmly position all contacts.

The connectors use a three-row contact grid on 4-mm centerlines. Plastic pins can be used to plug empty cavities in applications requiring selective loading.

The pc board-mounting connector is designed to be flange mounted.

Available with or without a formed in place flange seal.

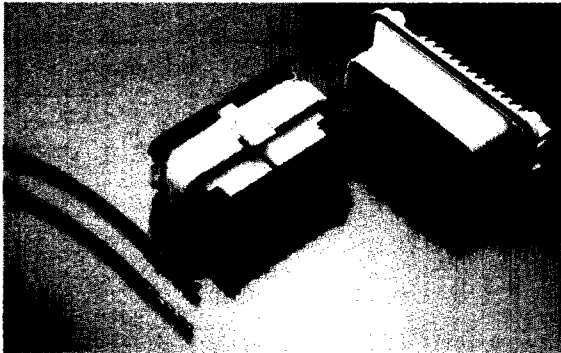
**AMPSEAL Automotive Plug Connector and Header Assembly** (Continued)**Material and Finish:****Housing**—UL94V-0 rated thermoplastic**Contacts**—**Receptacles**—Copper nickel alloy**Pins**—Copper zinc alloy**Seals**—Silicone rubber**Header Gasket**—Silicone rubber**Seal Plug**—Nylon**Performance Specifications:****Product Specification**

108-1329

**Application Specification**

114-16016

**Connector Part Number List**

No. of Positions	Type	Color	Additional Notes	Part Numbers
23	Plug Assembly	Black		770680-1
23	Plug Assembly	Natural		770680-2
23	Plug Assembly	Gray		770680-4
23	Plug Assembly	Blue		770680-5
23	Plug Socket	—	Tin	770520-1
23	Plug Socket	—	Gold	770520-3
23	Plug Socket	—	Tin, Loose Piece	770854-1
23	Plug Socket	—	Gold, Loose Piece	770854-3
23	Wire Seal Plug	—		770678-1
23	Right Angle Header	Black	With Flange Seal, Tin Pins	776087-1
23	Right Angle Header	Natural	With Flange Seal, Tin Pins	776087-2
23	Right Angle Header	Gray	With Flange Seal, Tin Pins	776087-4
23	Right Angle Header	Blue	With Flange Seal, Tin Pins	776087-5
23	Right Angle Header	Black	With Flange Seal, Gold Pins	1-776087-1
23	Right Angle Header	Natural	With Flange Seal, Gold Pins	1-776087-2
23	Right Angle Header	Gray	With Flange Seal, Gold Pins	1-776087-4
23	Right Angle Header	Blue	With Flange Seal, Gold Pins	1-776087-5
23	Right Angle Header	Black	Without Flange Seal, Tin Pins	770669-1
23	Right Angle Header	Natural	Without Flange Seal, Tin Pins	770669-2
23	Right Angle Header	Gray	Without Flange Seal, Tin Pins	770669-4
23	Right Angle Header	Blue	Without Flange Seal, Tin Pins	770669-5
23	Right Angle Header	Black	Without Flange Seal, Gold Pins	1-770669-1
23	Right Angle Header	Natural	Without Flange Seal, Gold Pins	1-770669-2
23	Right Angle Header	Gray	Without Flange Seal, Gold Pins	1-770669-4
23	Right Angle Header	Blue	Without Flange Seal, Gold Pins	1-770669-5
23	Vertical Header	Black	Without Flange Seal, Tin Pins	776200-1
23	Vertical Header	Natural	Without Flange Seal, Tin Pins	776200-2
23	Vertical Header	Gray	Without Flange Seal, Tin Pins	776200-4
23	Vertical Header	Blue	Without Flange Seal, Tin Pins	776200-5
23	Vertical Header	Black	Without Flange Seal, Gold Pins	1-776200-1
23	Vertical Header	Natural	Without Flange Seal, Gold Pins	1-776200-2
23	Vertical Header	Gray	Without Flange Seal, Gold Pins	1-776200-4
23	Vertical Header	Blue	Without Flange Seal, Gold Pins	1-776200-5
23	Vertical Header	Black	With Flange Seal, Tin Pins	776228-1
23	Vertical Header	Natural	With Flange Seal, Tin Pins	776228-2
23	Vertical Header	Gray	With Flange Seal, Tin Pins	776228-4
23	Vertical Header	Blue	With Flange Seal, Tin Pins	776228-5
23	Vertical Header	Black	With Flange Seal, Gold Pins	1-776228-1
23	Vertical Header	Natural	With Flange Seal, Gold Pins	1-776228-2
23	Vertical Header	Gray	With Flange Seal, Gold Pins	1-776228-4
23	Vertical Header	Blue	With Flange Seal, Gold Pins	1-776228-5



**AMPSEAL Automotive Plug Connector and Header Assembly** (Continued)

**Connector Part Number List** (Continued)

No. of Positions	Type	Color	Additional Notes	Part Numbers
35	Plug Assembly	Black		776164-1
35	Plug Assembly	Natural		776164-2
35	Plug Assembly	Gray		776164-4
35	Plug Assembly	Blue		776164-5
35	Right Angle Header	Black	Without Flange Seal, Gold Pins	1-776180-1
35	Right Angle Header	Natural	Without Flange Seal, Gold Pins	1-776180-2
35	Right Angle Header	Gray	Without Flange Seal, Gold Pins	1-776180-4
35	Right Angle Header	Blue	Without Flange Seal, Gold Pins	1-776180-5
35	Right Angle Header	Black	With Flange Seal, Gold Pins	1-776163-1
35	Right Angle Header	Natural	With Flange Seal, Gold Pins	1-776163-2
35	Right Angle Header	Gray	With Flange Seal, Gold Pins	1-776163-4
35	Right Angle Header	Blue	With Flange Seal, Gold Pins	1-776163-5
35	Vertical Header	Black	Without Flange Seal, Tin Pins	776230-1
35	Vertical Header	Natural	Without Flange Seal, Tin Pins	776230-2
35	Vertical Header	Gray	Without Flange Seal, Tin Pins	776230-4
35	Vertical Header	Blue	Without Flange Seal, Tin Pins	776230-5
35	Vertical Header	Black	Without Flange Seal, Gold Pins	1-776230-1
35	Vertical Header	Natural	Without Flange Seal, Gold Pins	1-776230-2
35	Vertical Header	Gray	Without Flange Seal, Gold Pins	1-776230-4
35	Vertical Header	Blue	Without Flange Seal, Gold Pins	1-776230-5
35	Vertical Header	Black	With Flange Seal, Tin Pins	776231-1
35	Vertical Header	Natural	With Flange Seal, Tin Pins	776231-2
35	Vertical Header	Gray	With Flange Seal, Tin Pins	776231-4
35	Vertical Header	Blue	With Flange Seal, Tin Pins	776231-5
35	Vertical Header	Black	With Flange Seal, Gold Pins	1-776231-1
35	Vertical Header	Natural	With Flange Seal, Gold Pins	1-776231-2
35	Vertical Header	Gray	With Flange Seal, Gold Pins	1-776231-4
35	Vertical Header	Blue	With Flange Seal, Gold Pins	1-776231-5

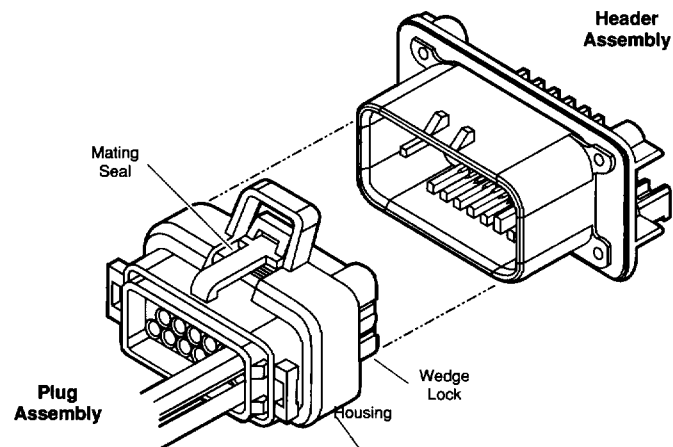

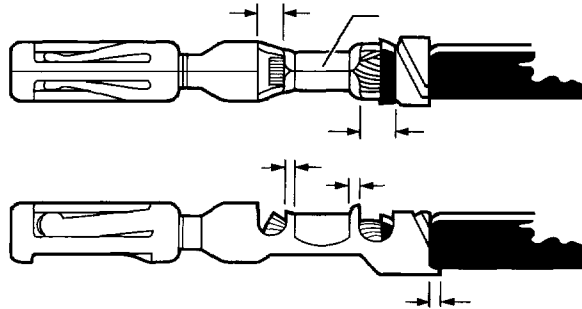
**AMPSEAL Automotive Plug Connector and Header Assembly** (Continued)**Contacts**

Wire		
Size (AWG)	Ins. Dia. Range	Applicator Part No.**
20	1.7-2.7 .067-.106	567333-2
18	1.7-2.7 .067-.106	567333-2
16	1.7-2.7 .067-.106	567333-2

\*\*Dash 1 is used in "T" Terminator with automatic equipment. Dash 2 is used in the AMP-O-ELECTRIC Model "K" Machine 565435-5. Refer to Applicator Instruction Sheet AI 8040 for applicator information.

Wire		
Size (AWG)	Ins. Dia. Range	Applicator Part No.**
20	1.7-2.7 .067-.106	58440-1
18	1.7-2.7 .067-.106	58440-1
16	1.7-2.7 .067-.106	58440-1

**Seal Plug**

All circuits are sealed by a diaphragm in the rubber wire seal. During plug connector assembly, the diaphragm is pierced as the contact passes through it. Unused circuit cavities, unless accidentally perforated, will remain sealed. AMPSEAL Automotive Plug 770678-1 is designed to keep out contaminants if diaphragm is pierced.

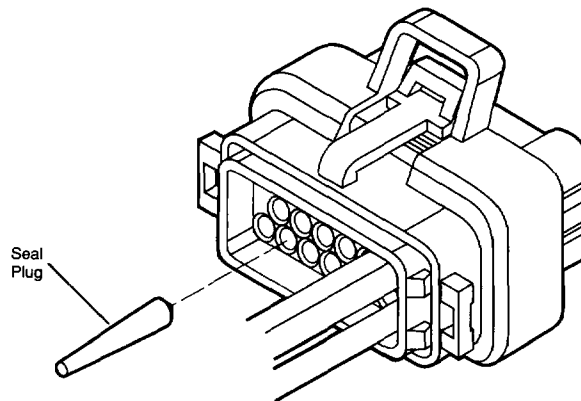

Seal Plug