

THIS DRAWING IS UNPUBLISHED. RELEASED FOR PUBLICATION  
 © COPYRIGHT - By - ALL RIGHTS RESERVED.

LOC		DIST		REVISIONS			
P	LTR	DESCRIPTION		DATE	DWN	APVD	
CM	00	R1	REVISED PER ECO-11-004587	11MAR11	RK	HMR	

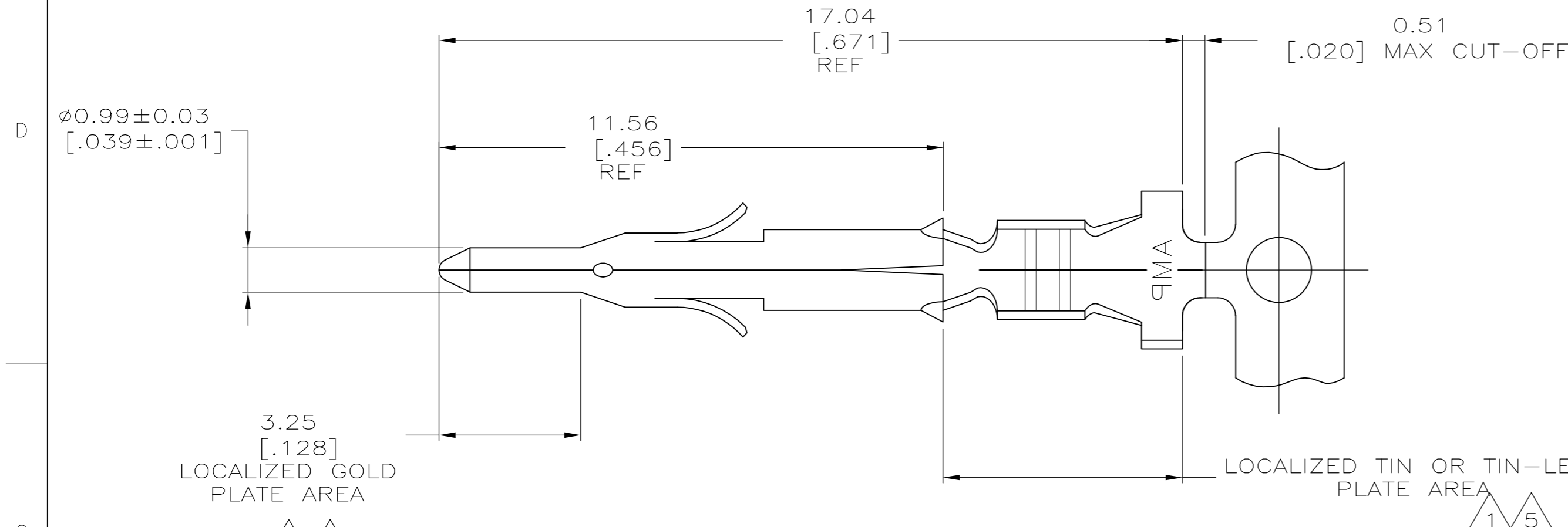

- 1 0.00076 [.000030] MIN GOLD IN LOCALIZED GOLD PLATE AREA AND 0.00254 [.000100] MIN BRIGHT TIN-LEAD IN LOCALIZED TIN-LEAD PLATE AREA OVER 0.00130 [.000050] MIN NICKEL.
- 2 WIRE RANGE: 0.3 - 0.9mm<sup>2</sup> (22-18 AWG).
- 3 INSULATION RANGE: 1.50-2.39 [.059-.094] DIA.
- 4 DIMENSIONS IN BRACKETS ARE IN INCHES.
- 5 0.00076 [.000030] MIN GOLD IN LOCALIZED GOLD PLATE AREA AND 0.00254 [.000100] MIN BRIGHT TIN IN LOCALIZED TIN PLATE AREA OVER 0.00130 [.000050] MIN NICKEL.

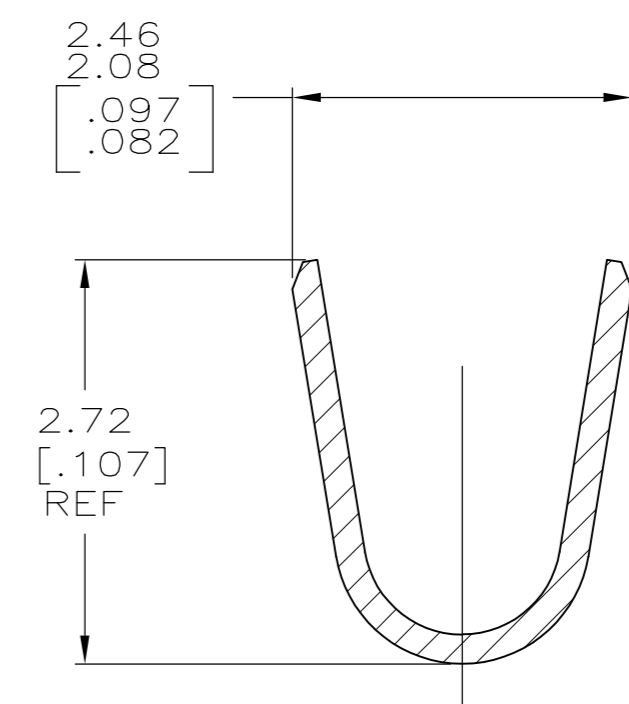
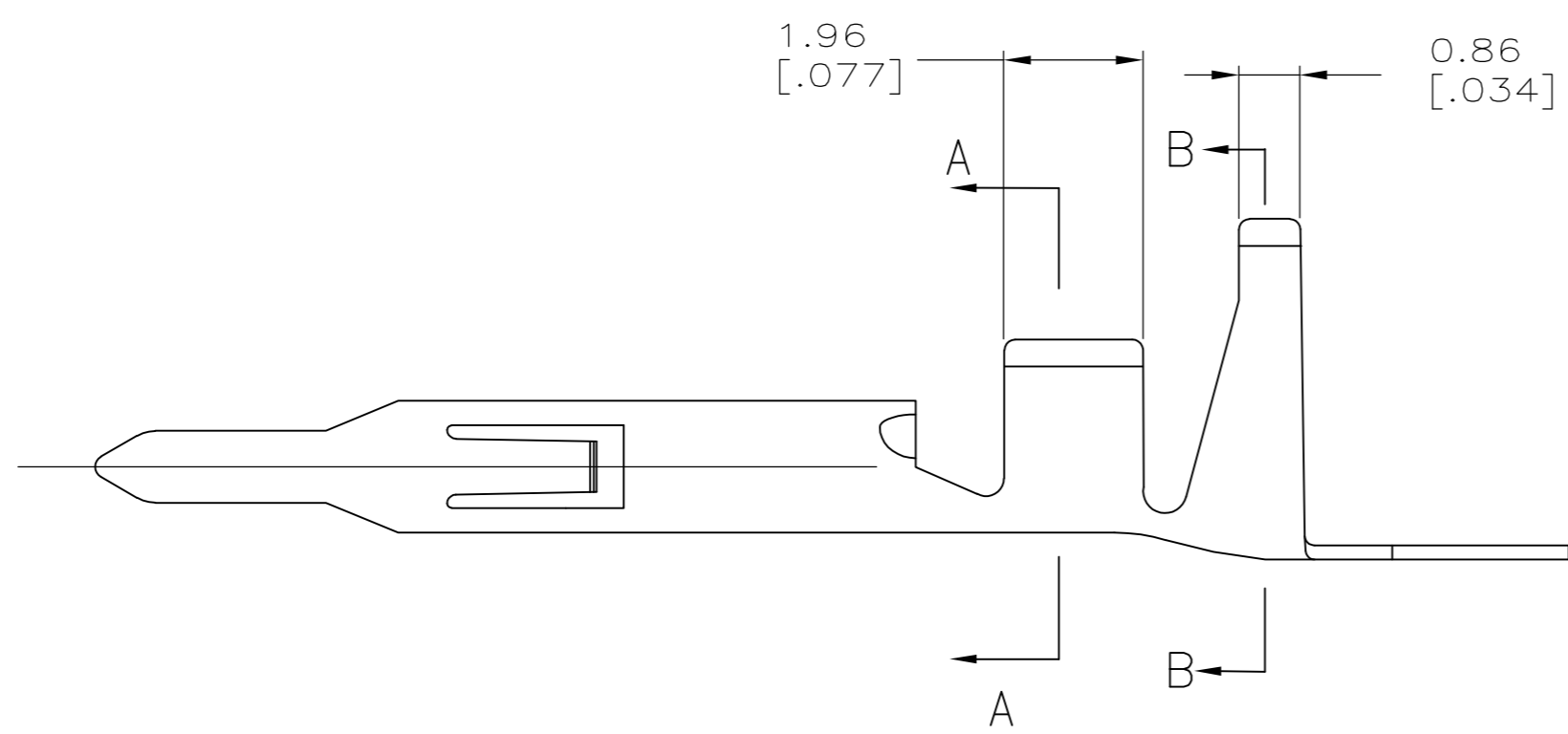

SECTION A-A  
SCALE 20:1

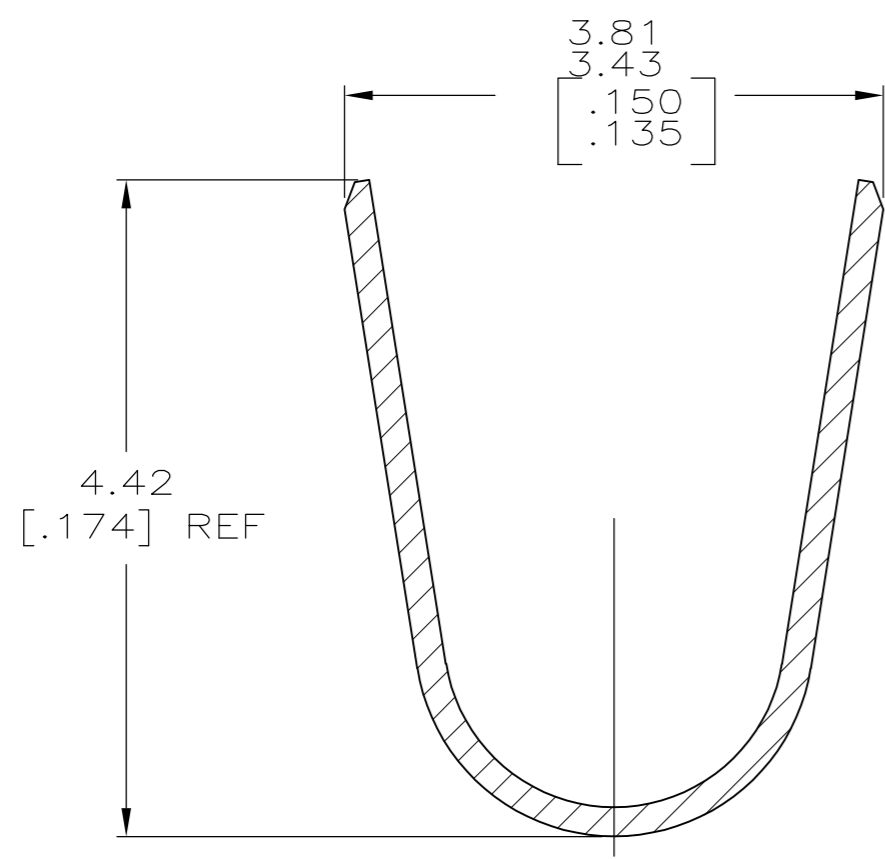

SECTION B-B  
SCALE 20:1

5	0.20 [.008] PHOS BRZ	1-770903-1
5	0.20 [.008] BRASS	1-770903-0
1	0.20 [.008] PH BRZ	770903-6
1	0.20 [.008] BRASS	770903-3
PRE-TIN	0.20 [.008] BRASS	770903-1
FINISH	MATERIAL	PART NUMBER

THIS DRAWING IS A CONTROLLED DOCUMENT.		DWN S. HOOVER 05MAR03	<b>STE</b> TE Connectivity	
DIMENSIONS: mm [INCHES]		CHK C. JONES 05MAR03		
TOLERANCES UNLESS OTHERWISE SPECIFIED:		APVD C. JONES 05MAR03	NAME PIN	
0 PLC ± -	1 PLC ± -	PRODUCT SPEC	MINI UNIVERSAL MATE-N-LOK(TM)	
2 PLC ± -	3 PLC ± 0.13[.005]	APPLICATION SPEC	SIZE A2	CAGE CODE 00779
4 PLC ± -	ANGLES ± -	WEIGHT -	DRAWING NO C-770903	RESTRICTED TO -
MATERIAL -	FINISH -	CUSTOMER DRAWING	SCALE 10:1	SHEET 1 of 1
			REV R1	