



Have a Question?
Chat with a Product Information Specialist

What can we help you find?

[Products](#) [Industries](#) [Resources](#) [About TE](#) [My Account](#) [Innovation](#) [Support Center](#)

81665-5 Product Details

[Share](#) [Print](#) [Email](#)

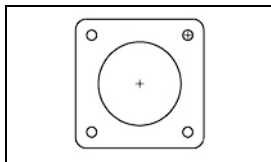

81665-5

TE Internal Number: 81665-5

Active

[View 3D PDF](#)

CPC Accessories

Always EU RoHS/ELV Compliant (Statement of Compliance)

Product Highlights:

- Accessory Type = Flange Seal
- Shell Size = 23
- Packaging Method = Individual
- RoHS compliant, ELV compliant
- Lead Free Solder Processes = Not relevant for lead free process

[View all Features](#)

Quick Links

- ▶ [Pricing & Availability](#)
- ▶ [Search for Tooling](#)
- ▶ [Product Feature Selector](#)
- ▶ [Contact Us About This Product](#)

[Add to My Part List](#) [Request Sample](#) [Find Similar Products](#) [Buy Product](#)

Documentation & Additional Information	
<p>Product Drawings:</p> <ul style="list-style-type: none"> • GASKET, FLANGE, CPC (PDF, English) <p>Catalog Pages/Data Sheets:</p> <ul style="list-style-type: none"> • AMP Circular Connectors for Commercial Signal & Powe... (PDF, English) <p>Product Specifications:</p> <ul style="list-style-type: none"> • None Available <p>Application Specifications:</p> <ul style="list-style-type: none"> • Circular Plastic Connectors (CPC) (PDF, English) <p>Instruction Sheets:</p> <ul style="list-style-type: none"> • Circular Plastic Connector (CPC) Series 45 Shielded ... (PDF, English) <p>CAD Files: (CAD Format & Compression Information)</p> <ul style="list-style-type: none"> • 2D Drawing (DXF, Version C) • 3D Model (IGES, Version C) • 3D Model (STEP, Version C) 	<p>Additional Information:</p> <ul style="list-style-type: none"> • Product Line Information <p>Related Products:</p> <ul style="list-style-type: none"> • Tooling

[List all Documents](#)

Product Features (Please use the Product Drawing for all design activity)	
<p>Product Type Features:</p> <ul style="list-style-type: none"> • Accessory Type = Flange Seal • Shell Size = 23 <p>Body Features:</p> <ul style="list-style-type: none"> • Cable Clamp Color = Black • Flange Material = Neoprene • Flange Seal Color = Black 	<p>Industry Standards:</p> <ul style="list-style-type: none"> • RoHS/ELV Compliance = RoHS compliant, ELV compliant • Lead Free Solder Processes = Not relevant for lead free process • RoHS/ELV Compliance History = Always was RoHS compliant <p>Packaging Features:</p> <ul style="list-style-type: none"> • Packaging Method = Individual <p>Other:</p> <ul style="list-style-type: none"> • Brand = AMP

Corporate Information

- [About TE](#)
- [Investors](#)
- [News Room](#)
- [Supplier Portal](#)
- [Careers](#)
- [Terms & Conditions](#)
- [Privacy Policy](#)

Quick Links

- [Distributor Inventory](#)
- [Product Cross Reference](#)
- [Documents & Drawings](#)
- [Product Compliance Support Center](#)
- [Site Map](#)

Customer Support

- [Email or Chat With Us](#)
- [Find a Phone Number](#)
- [Knowledge Base](#)
- [Manage Your Account](#)

Keep Me Informed

THIS DRAWING IS UNPUBLISHED. RELEASED FOR PUBLICATION
 © COPYRIGHT - By - ALL RIGHTS RESERVED.

LOC	DIST	REVISIONS			
P	LTR	DESCRIPTION	DATE	DWN	APVD
		C1	REVISED PER ECO-11-004820	11MAR11	RK HMR

NOTES:
 1 MATERIAL: NEOPRENE, BLACK.
 2 PRELIMINARY PART NUMER.

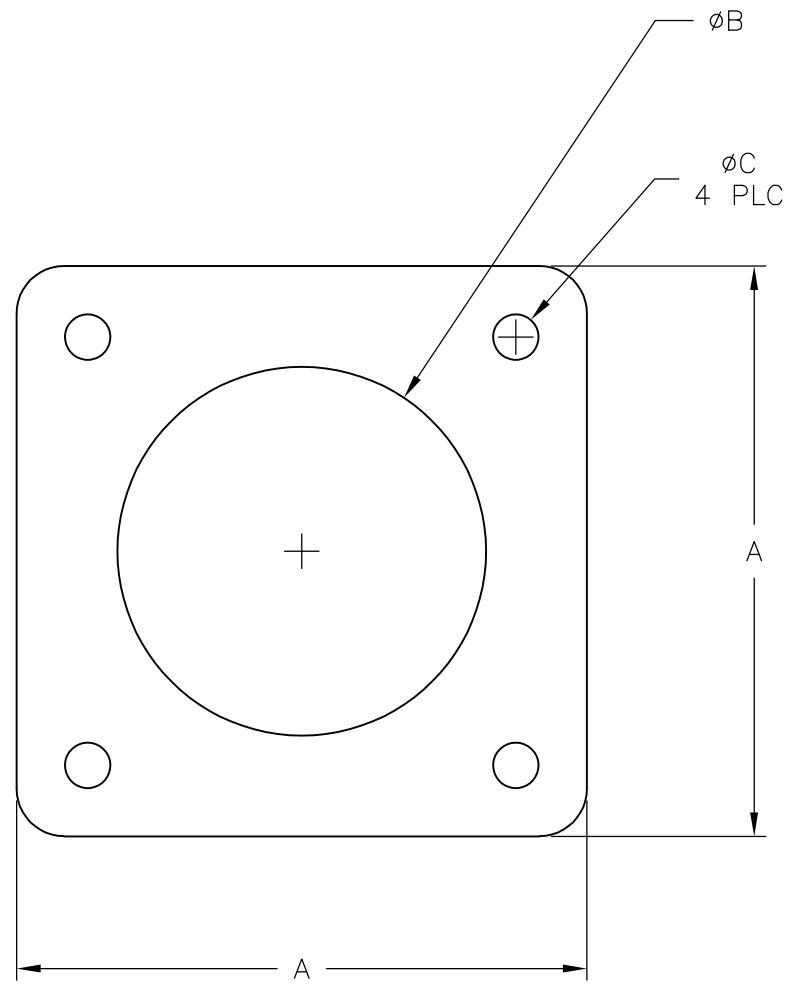

2	.125	1.030	1.185	14	81665-8
2	.120	1.110	1.530	22	81665-7
2	.142	1.492	1.950	28	81665-6
	.145	1.488	1.875	23	81665-5
	.120	.862	1.375	13	81665-4
	.120	.737	1.188	11	81665-3
	.145	1.100	1.500	17	81665-2
	.120	.970	1.500	-	81665-1
	C	B	A	CPC SHELL SIZE	PART NO.

THIS DRAWING IS A CONTROLLED DOCUMENT.		DWN S SCHLEGEL 16JUL03	STE TE Connectivity		
DIMENSIONS: INCHES		CHK S HEADER 7/16/03			
TOLERANCES UNLESS OTHERWISE SPECIFIED:		APVD S HEADER 7/16/03	NAME GASKET, FLANGE, CPC		
0 PLC ± - 1 PLC ± - 2 PLC ± - 3 PLC ± .015 4 PLC ± - ANGLES ± -		PRODUCT SPEC -	RESTRICTED TO -		
MATERIAL - 1		APPLICATION SPEC -	SIZE A3	CAGE CODE 00779	DRAWING NO C-81665
FINISH -		WEIGHT -	CUSTOMER DRAWING		SCALE NTS SHEET 1 OF 1 REV C1