

86286-1 Product Details

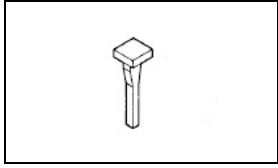

86286-1

TE Internal Number: 86286-1



.100 inch AMPMODU Receptacles

 Always EU RoHS/ELV Compliant (Statement of Compliance)

Product Highlights:

- Accessory
- Accessory Type = Keying Plug
- Mod II, Mod IV
- RoHS compliant, ELV compliant
- Lead Free Solder Processes = Wave solder capable to 240°C

Documentation & Additional Information

Product Drawings:

- [KEYING PLUG FOR MOD II, AND IV \(PDF, English\)](#)

Catalog Pages/Data Sheets:

- [AMPMODU_INTERCONNECTION_SYSTEM_SECTION5 \(PDF, English\)](#)

Product Specifications:

- None Available

Application Specifications:

- [AMPMODU Mod II and Mod IV Printed Circuit Board Conn... \(PDF, English\)](#)

Instruction Sheets:

- None Available

CAD Files: (CAD Format & Compression Information)

- [2D Drawing \(DXF, Version C\)](#)
- [3D Model \(IGES, Version C\)](#)
- [3D Model \(STEP, Version C\)](#)

Additional Information:

- [Product Line Information](#)

Additional Product Images:

- [Typical Application](#)

Related Products:

- [Tooling](#)

Product Features (Please use the Product Drawing for all design activity)

Product Type Features:

- [Product Type](#) = Accessory
- [Accessory Type](#) = Keying Plug
- [Connector Series](#) = Mod II, Mod IV

Body Features:

- Keying Plug Color = Natural
- Keying Plug Material = Nylon

Industry Standards:

- [Government/Industry Qualification](#) = No
- [RoHS/ELV Compliance](#) = RoHS compliant, ELV compliant
- [Lead Free Solder Processes](#) = Wave solder capable to 240°C
- [RoHS/ELV Compliance History](#) = Always was RoHS compliant

Other:

- [Brand](#) = AMP
- [Comment](#) = Plugs into receptacle contact.

THIS DRAWING IS UNPUBLISHED.

RELEASED FOR PUBLICATION

© COPYRIGHT - By -

ALL RIGHTS RESERVED.

LOC AD DIST 00

REVISIONS

P	LTR	DESCRIPTION	DATE	DWN	APVD
C1		REVISED PER ECO-11-004917	11MAR11	RK	HMR

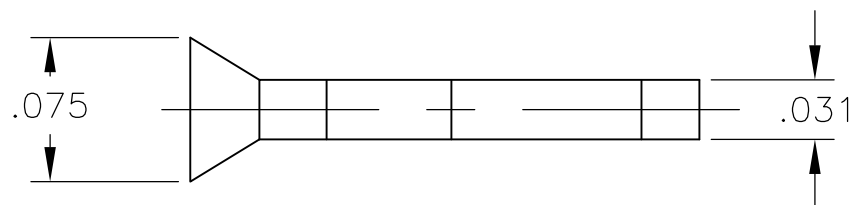
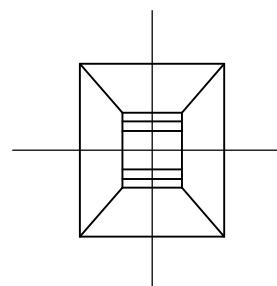
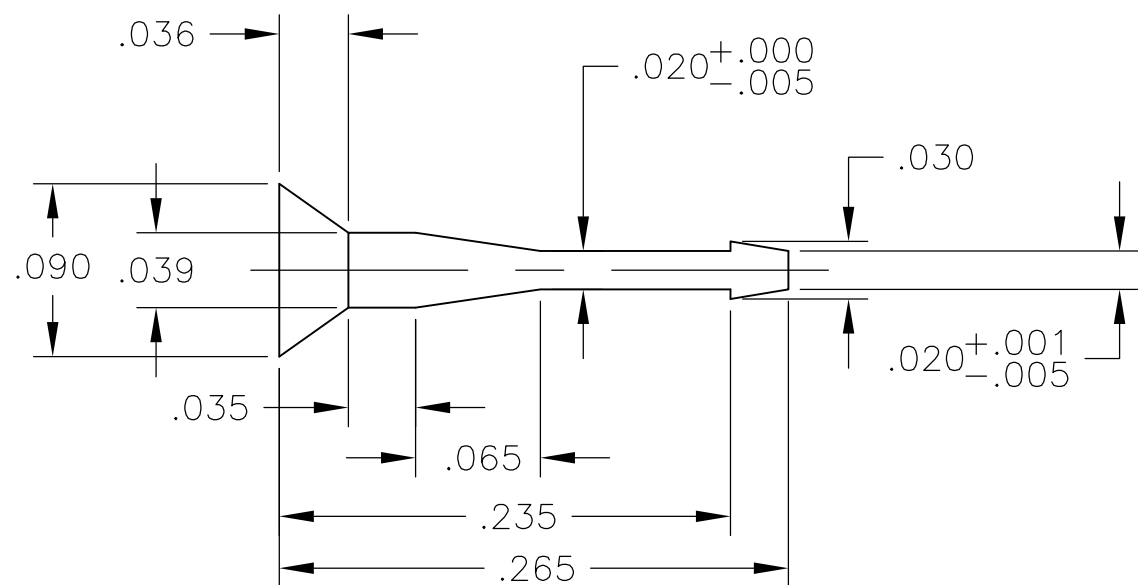

86286-1 AS SHOWN

THIS DRAWING IS A CONTROLLED DOCUMENT.		DWN R BROWN 17OCT01	 TE Connectivity			
DIMENSIONS: INCHES		CHK J OLSON 17OCT01				NAME
TOLERANCES UNLESS OTHERWISE SPECIFIED:		APVD J OLSON 17OCT01	KEYING PLUG FOR MOD II, AND IV			
<ul style="list-style-type: none"> 0 PLC ± - 1 PLC ± - 2 PLC ± - 3 PLC ± .003 4 PLC ± - ANGLES ± - 		PRODUCT SPEC	RESTRICTED TO			
MATERIAL NYLON 6/6 COLOR: NATURAL		FINISH -	WEIGHT -	SIZE A3	CAGE CODE 00779	DRAWING NO C-86286
CUSTOMER DRAWING			SCALE 10:1	SHEET 1 OF 1	REV C1	