

AMPMODU .031 x .062 [0.79 x 1.57] Interconnection System

Product Facts

- Rugged connector system featuring .031 x .062 (0.79 x 1.57) posts with mating receptacles.
- Current rating 5 amps max per contact. Varies due to ambient temperature, wire size and duty cycles.
- Available for board-to-board and wire-to-board applications.
- Posts available on strip for machine application directly to pc board or in housings for board mounting.
- Receptacles available for board mounting or wire crimping.
- Contacts available in both tin and gold plating.
- Flame retardant thermoplastic housings 94V-0 rated.
- Locking Clip contacts available to mate with .031 x .062 posts.
- Recognized under the Component Program of Underwriters Laboratories Inc., File No. E28476
- Certified by Canadian Standards Association, File No. LR 16455

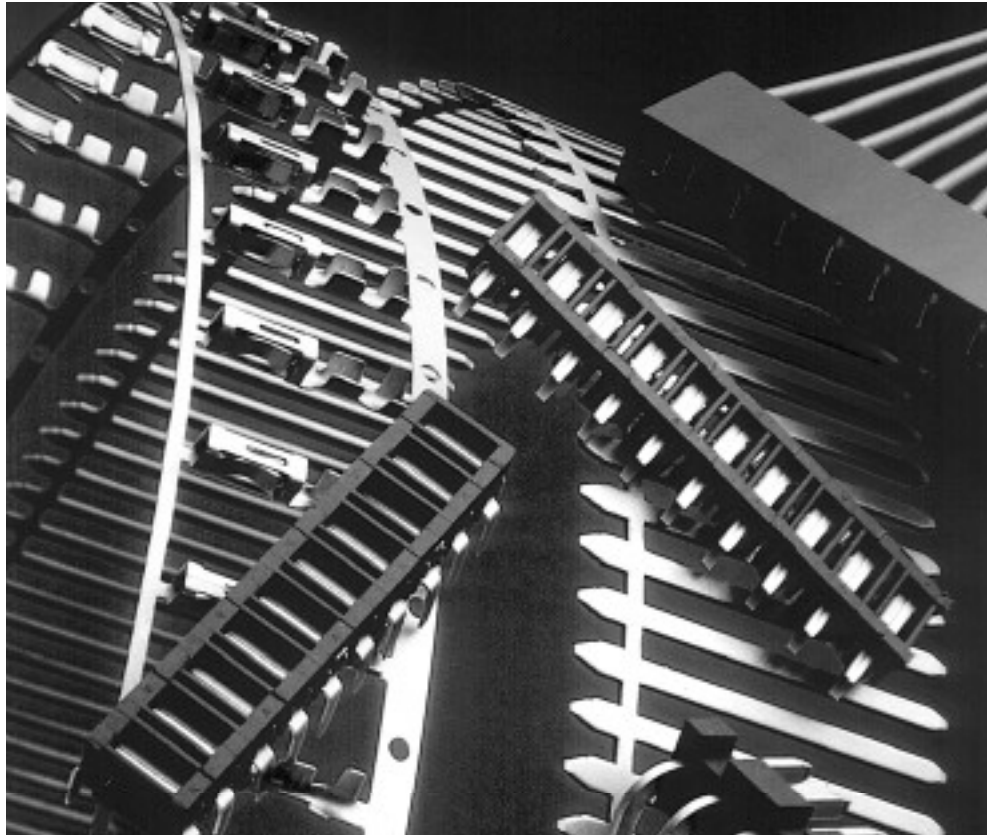

The .031 x .062 [0.79 x 1.57] interconnection system has served as an industry standard for modular packaging for over three decades. It is a rugged, large scale system designed for board-to-board and board-to-wire or cable applications that has offered millions of reliable interconnections and countless mating cycles. This versatile interconnection system successfully meets the requirements for most modular power supply packaging.

Board mounted receptacles and receptacle assemblies are available in various geometries, offering packaging interconnections

that include perpendicular, parallel and stacking capabilities. Machine applied terminations, through matched application equipment, are geared to virtually any production requirement, assuring the lowest possible applied cost.

Crimp snap-in receptacles for 26-18 AWG [0.12 – 0.9mm²] wire provide excellent discrete wire terminations. Housings for these contacts provide for ease of handling terminations in high density applications.

AMPMODU mating posts are supplied typically as header assemblies. They are available in various sizes to meet the interconnection and

packaging requirements of your system. However, in instances where packaging configurations do not lend themselves to the economies of assemblies, Tyco Electronics can provide for the discrete location of individual posts and receptacles.

If your interconnections require Top Entry, Bottom Entry and/or Side Entry for perpendicular, parallel and stacked configurations, the .031 x .062 [0.79 x 1.57] interconnection system can fulfill your needs with the lowest applied cost through efficient interconnections and supporting application equipment.

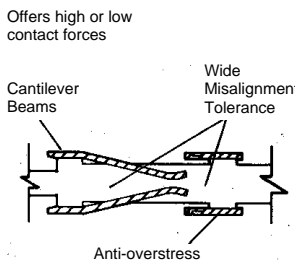
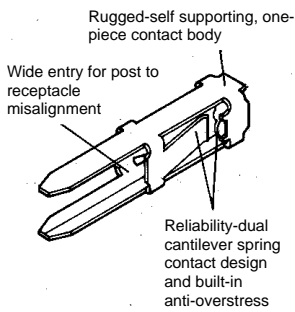
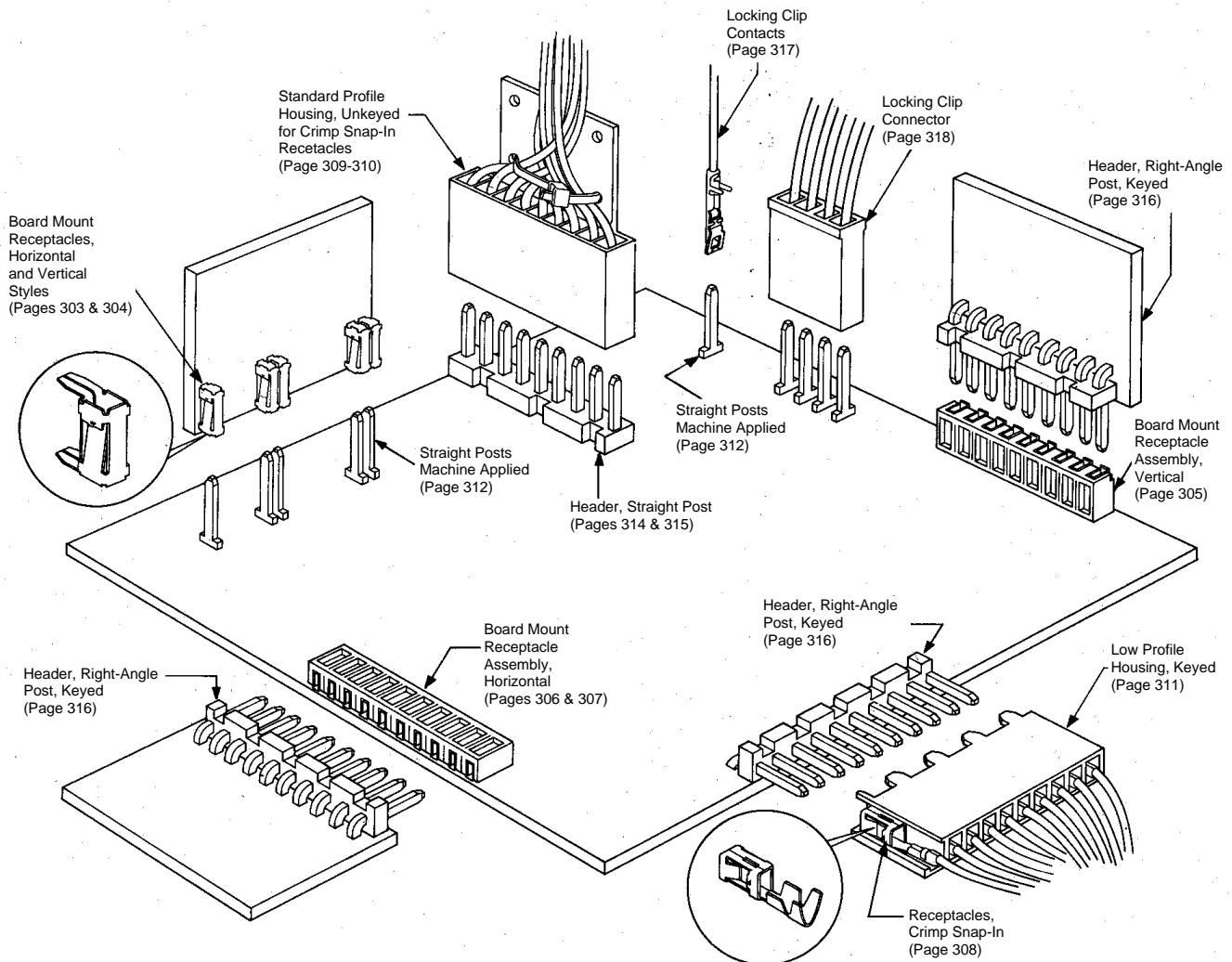

The AMPMODU receptacle cross-section is primarily rectangular, with rounded corners. Two integral cantilever beams contact the mating square or rectangular posts. Deflection of these spring members is limited by anti-overstress and excessive permanent deformation is prevented. This feature allows a wide range of tolerances for misalignment of mating contacts. The configuration of the receptacle completely encloses the spring members preventing damage during handling and assembly and makes the system compatible with automatic application techniques.

This design also permits the use of the receptacles without housings or encapsulation.

Note: Application of a contact lubricant is part of the manufacturing process of all AMPMODU tin-plated crimp products. However, it is not part of the manufacturing process of products that customers will solder, then clean. For these products, Tyco Electronics recommends that customers purchase a contact lubricant. (See application specification 114-25004 for further information.)

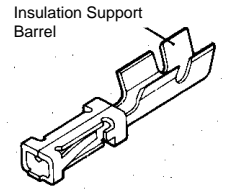

Wire Crimp Receptacle

Mod I Receptacles, Board Mount, .031 x .062 [0.79 x 1.57] Centerline

Vertical and Horizontal Board Mount

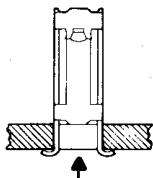

Bottom Post Entry Type A

Top Post Entry Type B

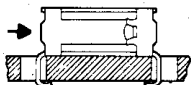
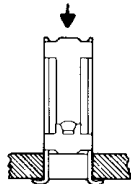

Horizontal Post Entry Type C

Receptacle Styles

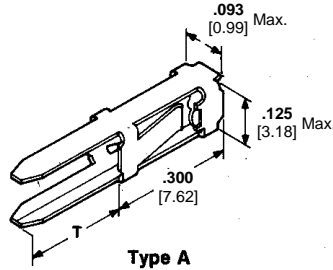

Type A

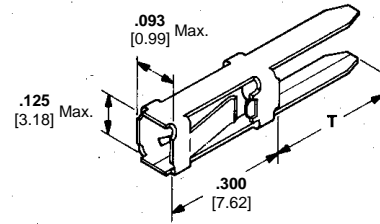

Type B

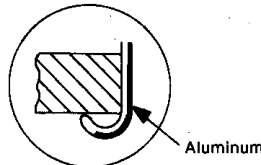

Typical Solder Resist Tab (Type A or B)

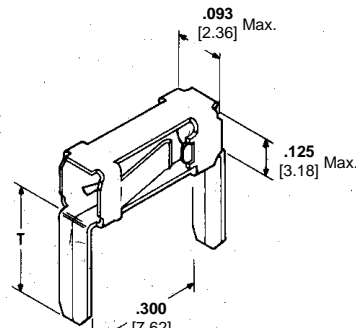

Type C

Related Product Data:

Recommended Board Layout for Type C—page 306

Mates with

Machine Applied Posts—page 312

Headers—pages 314-316

Application Tooling—page 319-323

Performance Specifications—page 324

Technical Documents (page 324):

Keying Plug

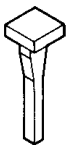

Part No. 86181-2
Use in Board Mount Receptacles

Recommended Board Layout for Receptacle Assemblies and Individual Receptacles (Type A and B)

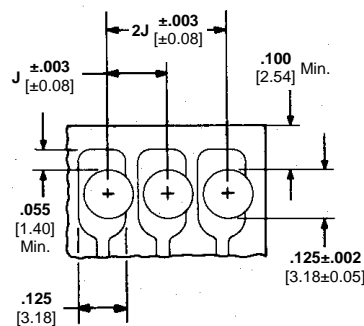

Round Hole (Post Entry Type A or B)

J-Receptacle centers may vary depending on requirements. For individual receptacles, minimum nominal centerline spacing between adjacent receptacles is .150 [3.81]; for receptacle assemblies, centerline spacing between adjacent receptacles is .156 [3.96]. The .003 [0.08] tolerances are not to accumulate over length of board. For solder mask, see Tyco Electronics Instruction Sheet 408-7411.

Note: Drawings depict normal use of the contact in a one or two-sided circuit board. When using plated thru-holes, refer to Tyco Electronics Engineering Report ER-001 and Tyco Electronics Instruction Sheet 408-7411. For solder mask, see Tyco Electronics Instruction Sheet 408-7411.

Material and Finish:

Copper alloy, plated as follows:

Plating A—Selectively plated .000030 [0.00076] gold on contact area, with gold flash over .000050 [0.00127] nickel on entire contact

Plating B—.000079 [0.00201] min. tin on entire contact

Plating C—(Solder Resist)—.000030 [0.00076] gold over .000050 [0.00127] nickel on contact area, .000500 [0.01270] aluminum on inside area of solder tines; remainder of contact unfinished

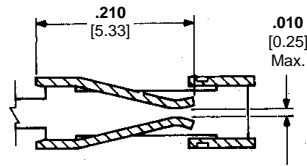

Standard Pressure Receptacle

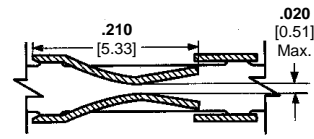

High Pressure Receptacle

Type	Board Thickness Range	Dimension T (Ref. Pg. 274)	Finish	Standard Pressure Part Nos.		High Pressure Part Nos.		Insertion Applicator No. for "U" Frame Machine
				Strip Form	Loose Piece	Strip Form	Loose Piece	
A	.070-.055 [1.78-1.40]	.112 [2.84]	Plating A	86477-2	86480-2	—	—	466376-1
			Plating B	86477-3	—	87316-3	—	466376-1
			Plating C (Solder Resist)	87772-2	—	—	—	466376-1
B	.070-.055 [1.78-1.40]	.112 [2.84]	Plating A	87003-1	87105-1	—	—	466376-1
			Plating B	87003-2	—	—	—	466376-1
			Plating C (Solder Resist)	87774-2	—	—	—	466376-1
C	.103-.055 [2.62-1.40]	.145 [3.68]	Plating A	85487-4	85493-4	86432-8	86434-6	565967-3
			Plating B	85487-3	—	86432-1	86434-1	

Notes: 1. All strip form parts in packaged quantities of 5,000 each.
2. All loose piece parts in packaged quantities of 500 each.

Mod I Receptacles, Board Mount

7

**Mod I Receptacle Assemblies, Vertical Board Mount,
.031 x .062 [0.79 x 1.57] Centerline**

Single Row .156 [3.96]
Centerline

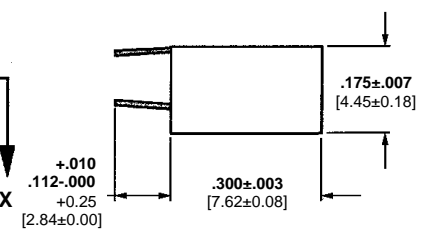
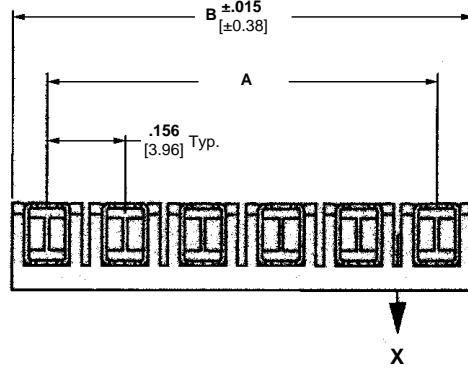
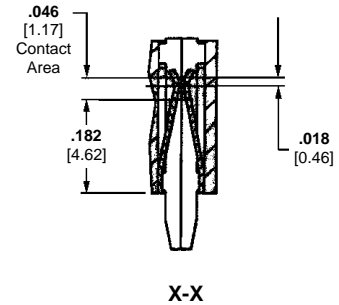
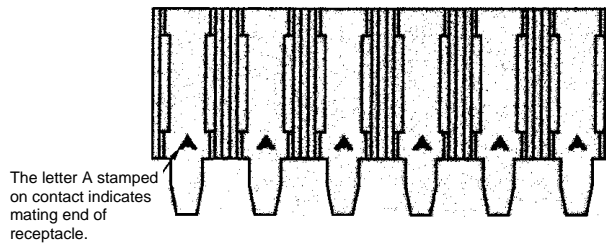
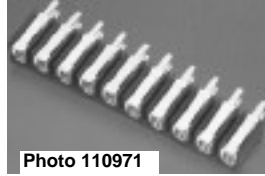

Material and Finish:

Housing—Black thermoplastic, 94V-0 rated

Contacts—Copper alloy, plated as follows:

Plating A—Selectively plated .000030 [0.00076] gold on contact area, with gold flash over .000050 [0.00127] nickel on entire contact

Plating B—.000079 [0.00201] min. tin on entire contact

Plating C—(Solder Resist)—.000030 [0.00076] gold over .000050 [0.00127] nickel on contact area, .000500 [0.01270] aluminum on inside area of solder tines; remainder of contact unfinished

Related Product Data:

Recommended Board Layout—page 306

Mates with

Machine Applied Posts—page 312

Headers—pages 314-316

Performance Specifications—page 324

Technical Documents (page 324):

No. of Pos.	Dimensions		Type A				Type B		
	A	B	Standard Pressure			High Pressure	Standard Pressure		
			Plating A	Plating B	Plating C	Plating B	Plating A	Plating B	Plating C
2	.156 [3.96]	.312 [7.92]	87984-2	87983-2	87989-2	87993-2	87986-2	87985-2	87990-2
3	.312 [7.92]	.468 [11.89]	87984-3	87983-3	87989-3	87993-3	87986-3	87985-3	87990-3
4	.468 [11.89]	.624 [15.85]	87984-4	87983-4	87989-4	87993-4	87986-4	87985-4	87990-4
5	.624 [15.85]	.780 [19.81]	87984-5	87983-5	87989-5	87993-5	87986-5	87985-5	87990-5
6	.780 [19.81]	.936 [23.77]	87984-6	87983-6	87989-6	87993-6	87986-6	87985-6	87990-6
7	.936 [23.77]	1.092 [27.74]	87984-7	87983-7	87989-7	87993-7	87986-7	87985-7	87990-7
8	1.092 [27.74]	1.248 [31.70]	87984-8	87983-8	87989-8	87993-8	87986-8	87985-8	87990-8
9	1.248 [31.70]	1.404 [35.66]	87984-9	87983-9	87989-9	87993-9	87986-9	87985-9	87990-9
10	1.404 [35.66]	1.560 [39.62]	1-87984-0	1-87983-0	1-87989-0	1-87993-0	1-87986-0	1-87985-0	1-87990-0
11	1.560 [39.62]	1.716 [43.59]	1-87984-1	1-87983-1	1-87989-1	1-87993-1	1-87986-1	1-87985-1	1-87990-1
12	1.716 [43.59]	1.872 [47.55]	1-87984-2	1-87983-2	1-87989-2	1-87993-2	1-87986-2	1-87985-2	1-87990-2
13	1.872 [47.55]	2.028 [51.51]	1-87984-3	1-87983-3	1-87989-3	1-87993-3	1-87986-3	1-87985-3	1-87990-3
14	2.028 [51.51]	2.184 [55.47]	1-87984-4	1-87983-4	1-87989-4	1-87993-4	1-87986-4	1-87985-4	1-87990-4
15	2.184 [55.47]	2.340 [59.44]	1-87984-5	1-87983-5	1-87989-5	1-87993-5	1-87986-5	1-87985-5	1-87990-5
16	2.340 [59.44]	2.496 [63.40]	1-87984-6	1-87983-6	1-87989-6	1-87993-6	1-87986-6	1-87985-6	1-87990-6
17	2.496 [63.40]	2.652 [67.36]	1-87984-7	1-87983-7	1-87989-7	1-87993-7	1-87986-7	1-87985-7	1-87990-7
18	2.652 [67.36]	2.808 [71.32]	1-87984-8	1-87983-8	1-87989-8	1-87993-8	1-87986-8	1-87985-8	1-87990-8
19	2.808 [71.32]	2.964 [75.29]	1-87984-9	1-87983-9	1-87989-9	1-87993-9	1-87986-9	1-87985-9	1-87990-9
20	2.964 [75.29]	3.120 [79.25]	2-87984-0	2-87983-0	2-87989-0	2-87993-0	2-87986-0	2-87985-0	2-87990-0

Keying Plug



Part No. 86181-2
(Use in Board Mount Receptacles)

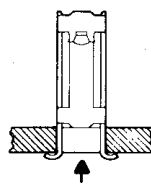

Post Entry Type A

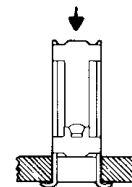

Post Entry Type B

**Mod I Receptacle Assemblies, Horizontal Board Mount,
.031 x .062 [0.79 x 1.57] Centerline**

Single Row .156 [3.96] Centers

Material and Finish:

Housing—Black thermoplastic, 94V-0 rated

Contacts—Copper alloy, plated as follows:

Plating A—Selectively plated .000030 [0.00076] gold contact area, with gold flash over .000050 [0.00127] nickel on entire contact

Plating B—.000079 [0.00201] min. tin on entire contact

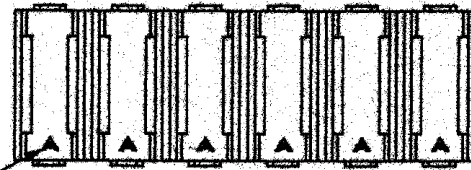

The letter A stamped on contact indicates mating end of receptacle.

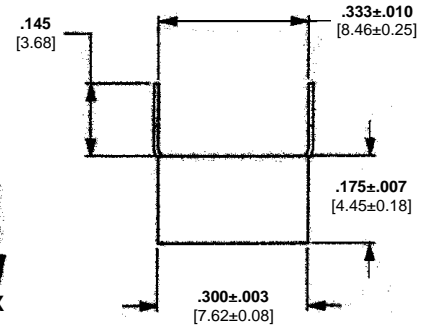
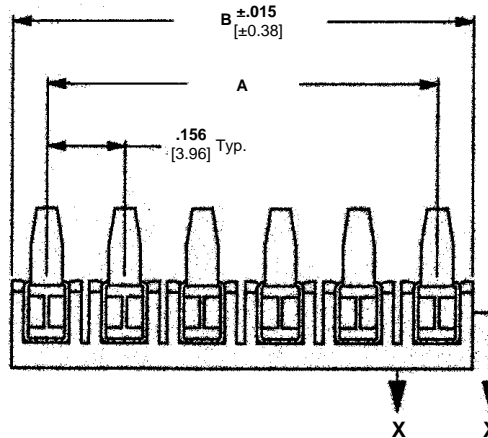
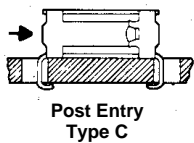
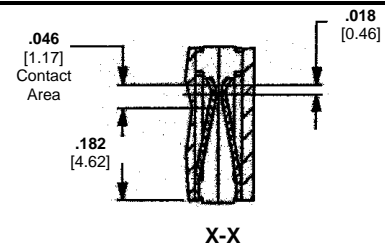

Related Product Data:

Mates with

Machine Applied Posts—page 312

Headers—pages 314-316

Performance Specifications—page 324

Technical Documents (page 324):

Recommended Board Layouts for Receptacle Assemblies and Individual Receptacles (Type C)

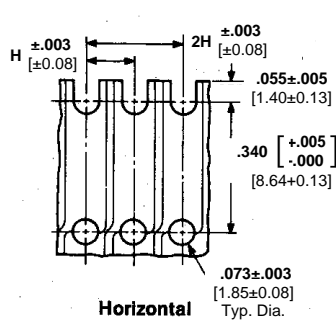

This configuration recommended for use with machine applied posts or headers with a .405 [10.29] minimum mating end post length.*

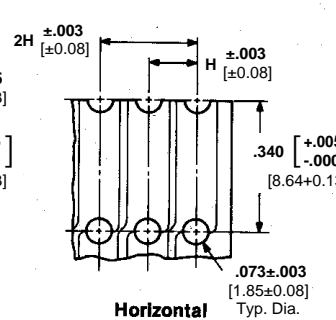

This configuration recommended for use with machine applied posts or headers with a .345 [18.76] minimum mating end post length.*

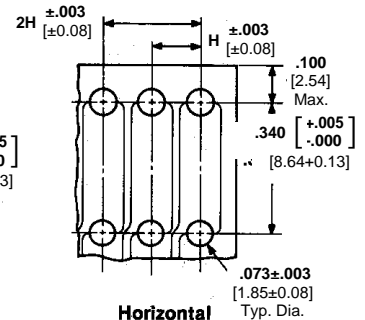

This configuration recommended for use with machine applied posts or headers with a .500 [12.70] minimum mating end post length.*

Keying Plug

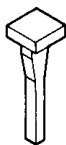

Part No. 86181-2
(Use in Board Mount Receptacles)

The mating post length is depicted by the A dimension on page 283 (machine applied posts) and the C dimension on pages 314-316 (headers).

H-Receptacle centers may vary depending on requirements. For individual receptacles, minimum nominal centerline spacing between adjacent receptacles is .125 [3.18] for receptacle assemblies, centerline spacing between adjacent receptacles is .156 [3.96]. The .003 [0.08] tolerances are not to accumulate over length of board.

**Mod I Receptacle Assemblies, Horizontal Board Mount,
.031 x .062 [0.79 x 1.57] Centerline** (Continued)

No. of Pos.	Dimensions		Standard Pressure		High Pressure
	A	B	Plating A	Plating B	Plating B
2	.156 [3.96]	.312 [7.92]	87988-2	87987-2	87995-2
3	.312 [7.92]	.468 [11.89]	87988-3	87987-3	87995-3
4	.468 [11.89]	.624 [15.85]	87988-4	87987-4	87995-4
5	.624 [15.85]	.780 [19.81]	87988-5	87987-5	87995-5
6	.780 [19.81]	.936 [23.77]	87988-6	87987-6	87995-6
7	.936 [23.77]	1.092 [27.74]	87988-7	87987-7	87995-7
8	1.092 [27.74]	1.248 [31.70]	87988-8	87987-8	87995-8
9	1.248 [31.70]	1.404 [35.66]	87988-9	87987-9	87995-9
10	1.404 [35.66]	1.560 [39.62]	1-87988-0	1-87987-0	1-87995-0
11	1.560 [39.62]	1.716 [43.59]	1-87988-1	1-87987-1	1-87995-1
12	1.716 [43.59]	1.872 [47.55]	1-87988-2	1-87987-2	1-87995-2
13	1.872 [47.54]	2.028 [51.51]	1-87988-3	1-87987-3	1-87995-3
14	2.028 [51.51]	2.184 [55.47]	1-87988-4	1-87987-4	1-87995-4
15	2.184 [55.47]	2.340 [59.44]	1-87988-5	1-87987-5	1-87995-5
16	2.340 [59.44]	2.496 [63.40]	1-87988-6	1-87987-6	1-87995-6
17	2.496 [63.40]	2.652 [67.36]	1-87988-7	1-87987-7	1-87995-7
18	2.652 [67.36]	2.808 [71.32]	1-87988-8	1-87987-8	1-87995-8
19	2.808 [71.32]	2.964 [75.29]	1-87988-9	1-87987-9	1-87995-9
20	2.964 [75.29]	3.120 [79.25]	2-87988-0	2-87987-0	2-87995-0

**Mod I Receptacles, Crimp Snap-In (Wire Applied),
.031 x .062 [0.79 x 1.57] Centerline**

Material and Finish:

Copper alloy, plated as follows:

Plating A—Selectively plated .000030 [0.00076] gold on contact area, with gold flash over .000050 [0.00127] nickel on entire contact

Plating B—.000016 [0.00041] min. tin on entire contact

Related Product Data:

Housings used in—pages 309-311

Mate with Machine Applied Posts—page 312

Headers—pages 314-316

Application Tooling—page 319-323

Performance Specification—page 324

Technical Documents (page 324):

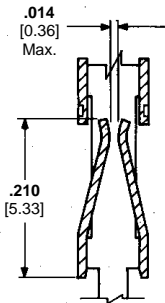
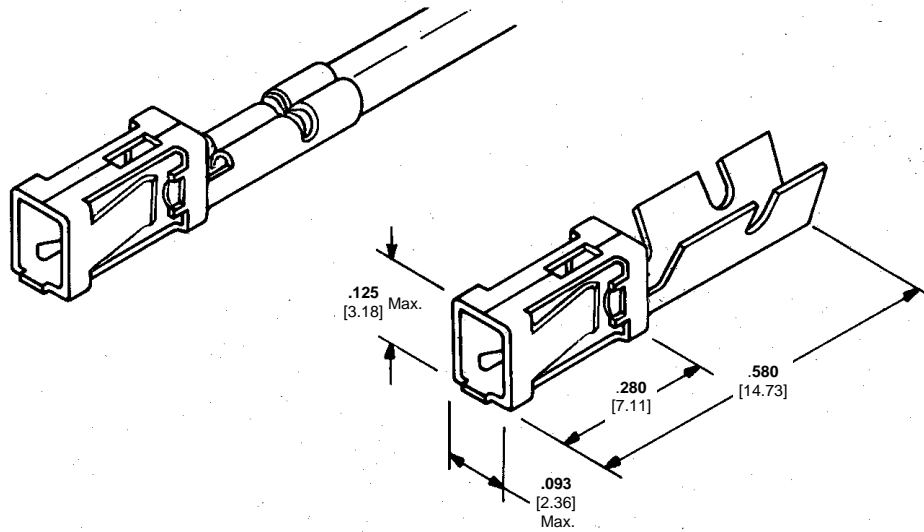

Standard Pressure Receptacle

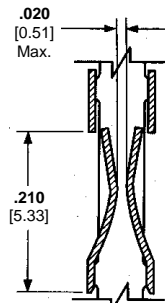

High Pressure Receptacle



Extraction Tool Part No. 843473-1
Part Instruction Sheet 408-9451

Wire Size Range AWG [mm ²]	Ins. Dia. Range	Finish	Standard Pressure			
			Strip Form		Loose Piece	
			Packaged Quantities	Part Nos.	Packaged Quantities	Part Nos.
22-18 [0.3-0.9]	.051-.090 [1.30-2.29]	Plating A	5,000	102099-2	500	102103-2
		Plating B	5,000	102099-5	500	102103-3

Wire Size Range AWG [mm ²]	Applicator (Standard Pressure)			Premium CERTI-CRIMP Hand Tool Part Number
	Part Number	Type	Used With Machine	
22-18	466764-3	HDM	Model "G" (AMP-O-LECTRIC)	90274-2
	466764-2	HDM	Model "K" (AMP-O-LECTRIC)	
	466764-1	HDM	CLS IV+ (AMPOMATOR)	
	466937-1	SCA	Stripper-Crimper (AMP-O-MATIC)	

AMP-O-LECTRIC KII Machine. Applicators also available for AMPOMATOR Lead Making Machines and Stripper/Crimper Machines. Consult Tyco Electronics.

Wire Size Range AWG [mm ²]	Ins. Dia. Range	Finish	High Pressure			
			Strip Form		Loose Piece	
			Packaged Quantities	Part Nos.	Packaged Quantities	Part Nos.
22-18 [0.3-0.9]	.051-.090 [1.30-2.29]	Plating A	5,000	102100-2	500	102104-2
		Plating B	5,000	102100-5	500	102104-3
26-22 [0.12-0.4]	0.42-.073 [1.07-1.85]	Plating A	5,000	102102-2	500	102106-2
		Plating B	5,000	102102-5	500	102106-3

Wire Size Range AWG [mm ²]	Applicator (High Pressure)			Premium CERTI-CRIMP Hand Tool Part Number
	Part Number	Type	Used With Machine	
22-18 [0.3-0.9]	466764-3	HDM	Model "G" (AMP-O-LECTRIC)	90274-2
	466764-2	HDM	Model "K" (AMP-O-LECTRIC)	
	466764-1	HDM	CLS IV+ (AMPOMATOR)	
	466937-1	SCA	Stripper-Crimper (AMP-O-MATIC)	
26-22 [0.12-0.4]	466763-2	HDM	Model "K" (AMP-O-LECTRIC)	90328-1
	466763-1	HDM	CLS IV+ (AMPOMATOR)	

AMP-O-LECTRIC KII Machine. Applicators also available for AMPOMATOR Lead Making Machines and Stripper/Crimper Machines. Consult Tyco Electronics.

Single Row, .156 [3.96]
Centers, Without Strain
Relief

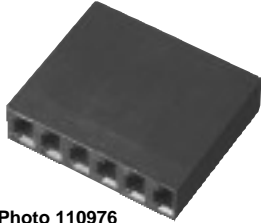

Photo 110976

Material:

Black thermoplastic, flame retardant,
94V-0 rated

Related Product Data:

Contacts used with—page 308

Mate with

Machine Applied Posts—page 312

Headers—pages 314-316

Performance Specifications—page 324

Technical Documents (page 324):

**Mod I Receptacle Housings, Standard Profile, Unkeyed,
.031 x .062 [0.79 x 1.57] Centerline**

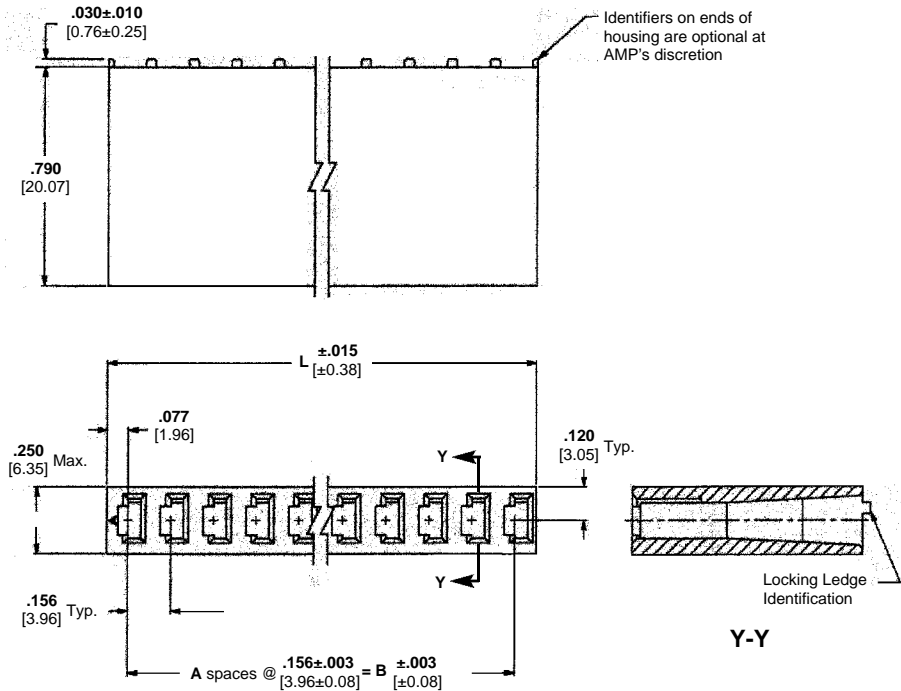

No. of Pos.	Dimensions			Housing Part Nos.	
	A	B	L	Stamped ¹	Unstamped ²
2	1	.156 [3.96]	.312 [7.92]	—	2-87025-5
3	2	.312 [7.92]	.468 [11.89]	—	2-87025-1
4	3	.468 [11.89]	.624 [15.85]	—	1-87025-3
5	4	.624 [15.85]	.780 [19.81]	—	2-87025-3
6	5	.780 [19.81]	.936 [23.77]	87025-1	87025-2
7	6	.936 [23.77]	1.092 [27.74]	—	3-87025-4
8	7	1.092 [27.74]	1.248 [31.70]	—	1-87025-6
9	8	1.248 [31.70]	1.404 [35.66]	87025-9	1-87025-0
10	9	1.404 [35.66]	1.560 [39.62]	1-87025-7	1-87025-8
11	10	1.560 [39.62]	1.716 [43.59]	—	3-87025-6
12	11	1.716 [43.59]	1.872 [47.55]	1-87025-1	1-87025-2
13	12	1.872 [47.55]	2.028 [51.51]	—	3-87025-0
14	13	2.028 [51.51]	2.184 [55.47]	—	3-87025-8
15	14	2.184 [55.47]	2.340 [59.44]	—	3-87025-2
16	15	2.340 [59.44]	2.496 [63.40]	—	2-87025-0
17	16	2.496 [63.40]	2.652 [67.36]	—	4-87025-0
18	17	2.652 [67.36]	2.808 [71.32]	—	87025-4
19	18	2.808 [71.32]	2.964 [75.29]	—	87025-6
20	19	2.964 [75.29]	3.120 [79.25]	—	87025-8
25	24	3.744 [95.10]	3.900 [99.06]	—	5-87025-0

Notes: ¹Markings on housing.
²No markings on housing.

Mod I Receptacle Housings

7

**Mod I Receptacle Housings, Standard Profile, Unkeyed,
.031 x .062 [0.79 x 1.57] Centerline (Continued)**

Single Row, .156 [3.96]
Centers, With Strain Relief



Photo 110998

Material:

Black thermoplastic, flame retardant,
94V-0 rated

Related Product Data:

Contacts used with—page 308

Mate with
Machine Applied Posts—page 312

Headers—pages 314-316

Performance Specifications—
page 324

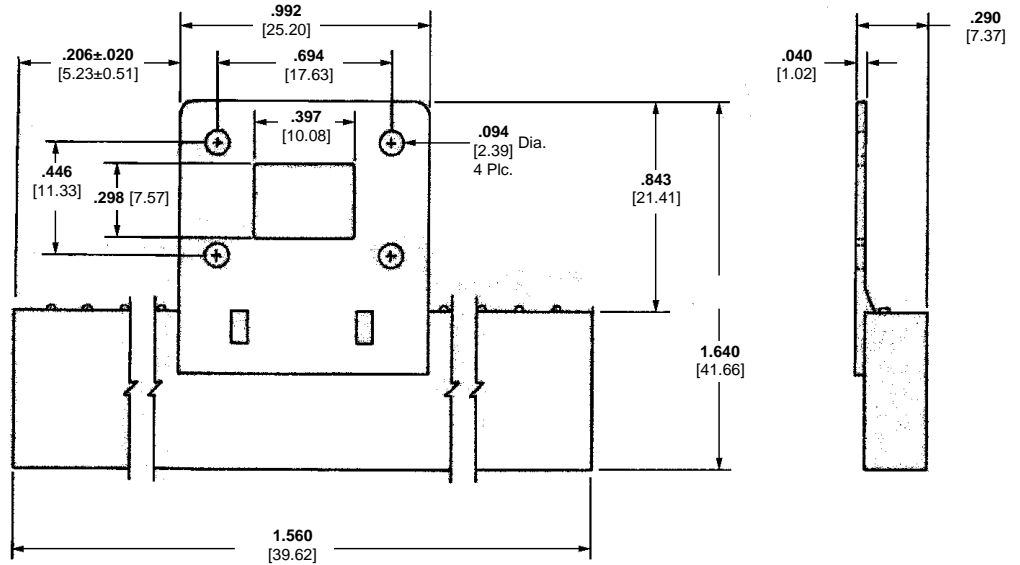

10 Position Receptacle Housing, Part No. 1-102090-0

Technical Documents (page 324):

Single Row, .156 [3.96] Centers

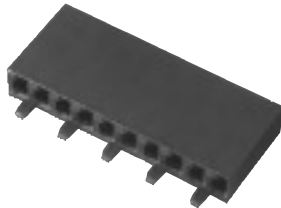

Photo 110974

Material:

Black thermoplastic, flame retardant, 94V-0 rated

Related Product Data:

Contacts used with—page 308

Mate with

Headers—pages 314-316

Performance Specifications—

page 324

Technical Documents (page 324):

Mod I Receptacle Housings, Low Profile, Keyed, .031 x .062 [0.79 x 1.57] Centerline

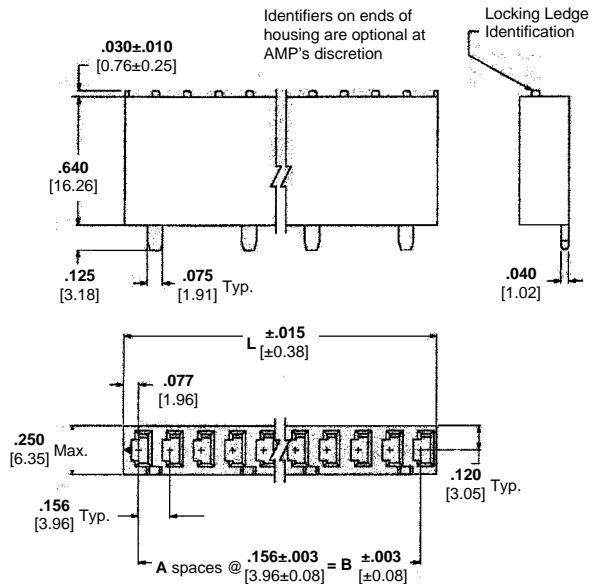

No. of Pos.	Dimensions			No. of Keys	Housing Part Nos. (Unstamped) ¹	Key Locations
	A	B	L			
2	1	.156 [3.96]	.312 [7.92]	1	87159-3	A
3	2	.312 [7.92]	.468 [11.89]	1	87159-4	A
4	3	.468 [11.89]	.624 [15.85]	2	87159-5	A,C
5	4	.624 [15.85]	.780 [19.81]	2	87159-1	A,D
6	5	.780 [19.81]	.936 [23.77]	3	87159-6	A,C,E
7	6	.936 [23.77]	1.092 [27.74]	3	87159-7	A,C,E
8	7	1.092 [27.74]	1.248 [31.70]	4	87159-8	A,C,E,G
9	8	1.248 [31.70]	1.404 [35.66]	3	87159-9	A,D,G
10	9	1.404 [35.66]	1.560 [39.62]	5	1-87159-0	A,C,E,G,J
11	10	1.560 [39.62]	1.716 [43.59]	4	1-87159-1	A,D,G,K
12	11	1.716 [43.59]	1.872 [47.55]	6	1-87159-2	A,C,E,G,J,L
13	12	1.872 [47.55]	2.028 [51.51]	4	87159-2	A,D,J,M
14	13	2.028 [51.51]	2.184 [55.47]	7	1-87159-3	A,C,E,G,J,L,N
15	14	2.184 [55.47]	2.340 [59.44]	5	1-87159-4	A,D,G,K,N
16	15	2.340 [59.44]	2.496 [63.40]	8	1-87159-5	A,C,E,G,J,L,N,Q
17	16	2.496 [63.40]	2.652 [67.36]	6	1-87159-6	A,D,G,K,N,R
18	17	2.652 [67.36]	2.808 [71.32]	6	1-87159-7	A,D,F,J,P,S
19	18	2.808 [71.32]	2.964 [75.29]	8	1-87159-8	B,D,F,J,L,N,Q,S
20	19	2.964 [75.29]	3.120 [79.25]	10	1-87159-9	A,C,E,G,J,L,N,Q,S,U
25	24	3.744 [95.10]	3.900 [99.06]	11	2-87159-4	A,C,E,H,K,M,Q,S,U,W,Y

¹No marking on housing.

Keying Plug

Material: Natural Color Nylon

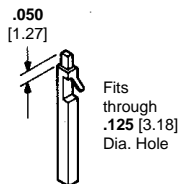

Part No. 87116-2

Keying Plug References

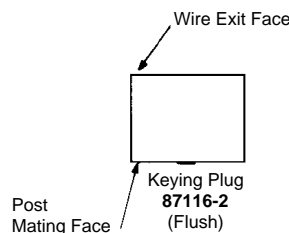

For Standard Housings

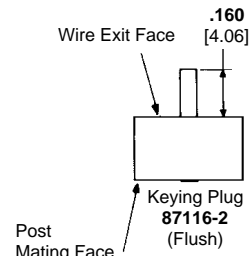

For Low Profile Housings

Mod I Posts, Machine Applied, .031 x .062 [0.79 x 1.57] Centerline

Straight Posts

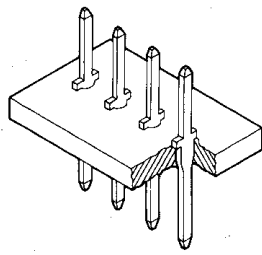

Typical Assembly

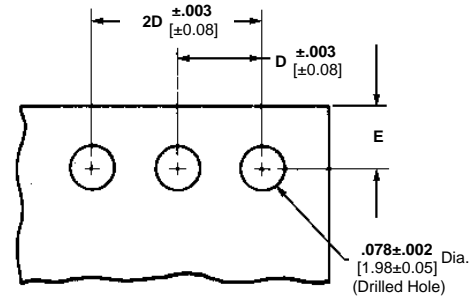
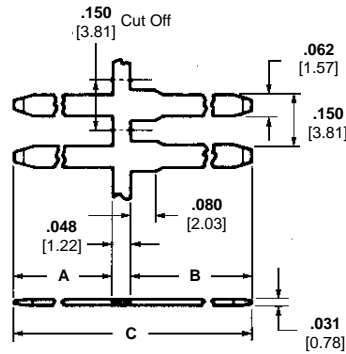

Recommended Mounting Holes

Material and Finish:

Brass, plated as follows:

Plating A—.000030 [0.00076] gold over .000050 [0.00127] nickel on entire post

Plating B—.0001000-.000200 [0.00254-0.00508] bright tin over .000050 [0.00127] nickel on entire post

Related Product Data:

Mate with Board Mount Receptacles—pages 303 & 304

Board Mount Receptacle Assemblies—pages 305-307

Crimp Snap-In Receptacles and Housings—pages 308-310

Locking Clip Contacts & Housings—pages 317-318 (see page 317 for recommended post length).

Application Tooling—pages 319-323

Performance Specifications—page 324

Technical Documents (page 324):

D—Post centers may vary depending on requirements. Minimum nominal centerline spacing between adjacent contacts is .125 [3.18]; .003 [0.08] tolerances not to accumulate over length of board.

E—Post center location from edge of board may vary to satisfy application.

Dimensions			Finish	Part Nos.	
A	B	C		Strip Form ¹	Loose Piece ²
.360 [9.14]	.187 [4.75]	.595 [15.11]	Plating A	86147-7	86182-7
			Plating B	86147-2	86182-2
.380 [9.65]	.320 [8.13]	.748 [19.00]	Plating A	1-86147-5	1-86182-5
			Plating B	86147-9	86182-9
.400 [10.16]	.125 [3.18]	.573 [14.55]	Plating A	4-86147-2	2-86182-9
			Plating B	3-86147-7	2-86182-5
.480 [12.19]	.187 [4.75]	.715 [18.16]	Plating A	1-86147-8	1-86182-8
			Plating B	2-86147-2	2-86182-2
.565 [14.35]	.187 [4.75]	.800 [20.32]	Plating A	86147-8	86182-8
			Plating B	86147-1	86182-1
.800 [20.32]	.150 [3.81]	.998 [25.35]	Plating A	1-86147-2	1-86182-2
			Plating B	1-86147-0	1-86182-0

¹ Packaging quantity of 20,000 per reel.

² Packaging quantity of 1,000 per bag.

Note: Strip form posts applied with Insertion Machine No. 3-457382-1, includes power unit and applicator.

Mod I Posts,
Machine Applied

7

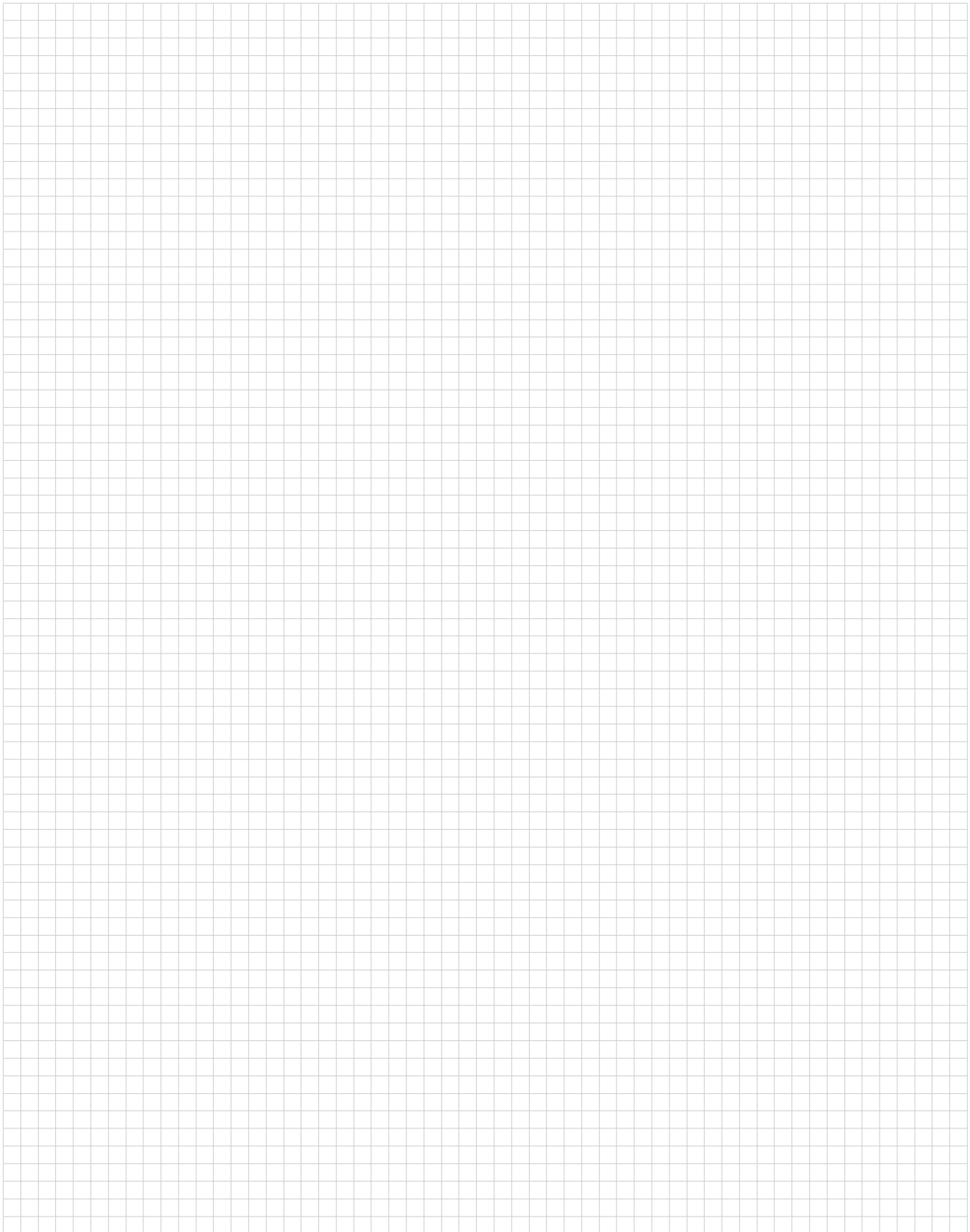

Mod I Headers, Straight Post, Keyed, .031 x .062 [0.79 x 1.57] Centerline

Single Row, .156 [3.96] Centers

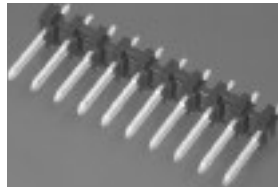

Photo 110972

Material and Finish:

Housing—Black thermoplastic, 94V-0 rated

Posts—Brass, plated as follows:

Plating A—Selectively plated .00030 [0.00076] gold on contact area, with gold flash over .000050 [0.00127] min. nickel on entire post

Plating B—.000100-.000200 [0.00254-0.00508] bright tin-lead over .000030 [0.00762] nickel on entire post

Related Product Data:

Mate with

Board Mount Receptacles—pages 303 & 304

Board Mount Receptacle Assemblies—pages 305-307

Crimp Snap-In Receptacles and Housings—pages 308-310

Locking Clip Contacts & Housings—pages 317 & 318 (see page 317 for recommended post length).

Performance Specifications—page 324

Technical Documents (page 324):

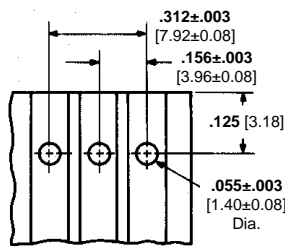

Recommended Board Layout

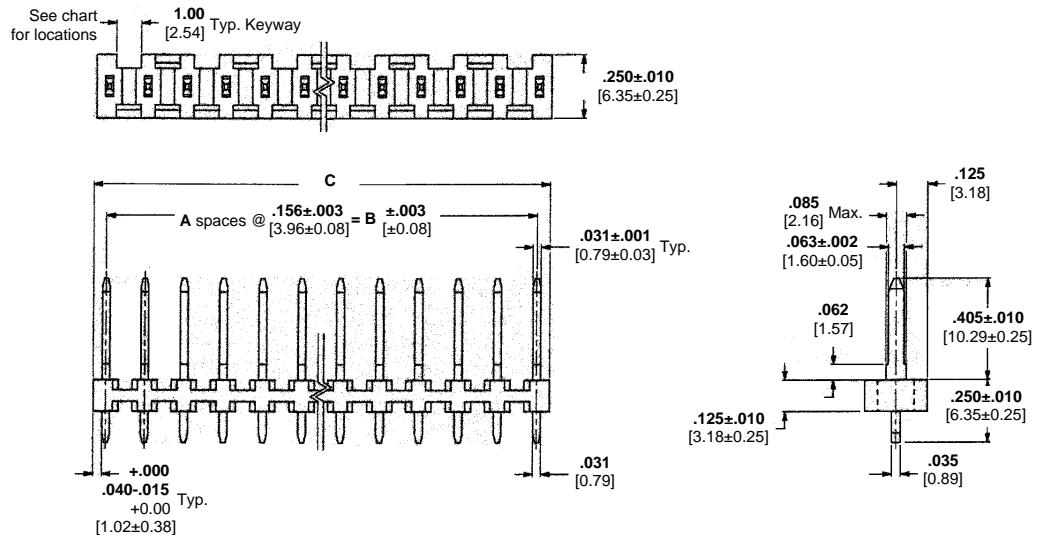

Keyway Locations (Ref only)

No. of Pos.	Dimensions			No. of Keying Slots	Post Height D=.405 [10.29]		Post Height D=.587 [14.91]		Keyway Locations
	A	B	C		Plating A	Plating B	Plating A	Plating B	
2	1	.156 [3.96]	.267 [6.78]	1	85829-2	87160-4	87247-2	87262-2	A
3	2	.312 [7.92]	.423 [10.74]	1	85829-3	87160-5	87247-3	87262-3	A
4	3	.468 [11.89]	.579 [14.71]	2	85829-4	87160-6	87247-4	87262-4	A,C
5	4	.624 [15.85]	.735 [18.67]	2	85829-5	87160-1	87247-5	87262-5	A,D
6	5	.780 [19.81]	.891 [22.63]	3	85829-6	87160-7	87247-6	87262-6	A,C,E
7	6	.936 [23.77]	1.047 [26.59]	3	85829-7	87160-8	87247-7	87262-7	A,C,E
8	7	1.092 [27.74]	1.203 [30.56]	4	85829-8	87160-9	87247-8	87262-8	A,C,E,G
9	8	1.248 [31.70]	1.359 [34.52]	3	85829-9	1-87160-0	87247-9	87262-9	A,D,G
10	9	1.404 [35.66]	1.515 [38.48]	5	1-85829-0	1-87160-1	1-87247-0	1-87262-0	A,C,E,G,J
11	10	1.560 [39.62]	1.671 [42.44]	4	1-85829-1	1-87160-2	1-87247-1	1-87262-1	A,D,G,K
12	11	1.716 [43.59]	1.827 [46.41]	6	1-85829-2	1-87160-3	1-87247-2	1-87262-2	A,C,E,G,J,L
13	12	1.872 [47.55]	1.983 [50.37]	4	1-85829-3	87160-2	1-87247-3	1-87262-3	A,D,J,M
14	13	2.028 [51.51]	2.139 [54.33]	7	1-85829-4	1-87160-4	1-87247-4	1-87262-4	A,C,E,G,J,L,N
15	14	2.184 [55.47]	2.295 [58.29]	5	1-85829-5	1-87160-5	1-87247-5	1-87262-5	A,D,G,K,N
16	15	2.340 [59.44]	2.451 [62.26]	8	1-85829-6	1-87160-6	1-87247-6	1-87262-6	A,C,E,G,J,L,N,Q
17	16	2.496 [63.40]	2.607 [66.22]	6	1-85829-7	1-87160-7	1-87247-7	1-87262-7	A,D,G,K,N,R
18	17	2.652 [67.36]	2.763 [70.18]	7	1-85829-8	1-87160-8	1-87247-8	1-87262-8	A,D,F,J,M,P,S
19	18	2.808 [71.32]	2.919 [74.14]	8	1-85829-9	1-87160-9	1-87247-9	1-87262-9	B,D,F,J,L,N,Q,S
20	19	2.964 [75.29]	3.075 [78.11]	10	2-85829-0	2-87160-0	2-87247-0	2-87262-0	A,C,E,G,J,L,N,Q,S,U
21	20	3.120 [79.25]	3.231 [82.07]	7	2-85829-1	2-87160-1	2-87247-1	2-87262-1	A,D,G,K,N,R,U
22	21	3.276 [83.21]	3.387 [86.03]	11	2-85829-2	2-87160-2	2-87247-2	2-87262-2	A,C,E,G,J,L,N,Q,S,U,W
23	22	3.432 [87.17]	3.543 [89.99]	8	2-85829-3	2-87160-3	2-87247-3	2-87262-3	A,D,G,K,N,R,U,X
24	23	3.588 [91.14]	3.699 [93.95]	12	2-85829-4	2-87160-4	2-87247-4	2-87262-4	A,C,E,G,J,L,N,Q,S,U,W,Y
25	24	3.744 [95.10]	3.855 [97.92]	11	2-85829-5	2-87160-5	2-87247-5	2-87262-5	A,C,E,H,K,M,Q,S,U,W,Y

**Mod I Headers, Straight Post, Keyed,
.031 x .062 [0.79 x 1.57] Centerline** (Continued)

No. of Pos.	Dimensions			No. of Keying Slots	Post Height D=.750 [19.05]		Post Height D=1.187 [30.15]		Post Height D=1.310 [33.27]		Keyway Locations
	A	B	C		Plating A	Plating B	Plating A	Plating B	Plating A	Plating B	
	2	1	.156 [3.96]		.267 [6.78]	1	85923-2	85875-7	87283-2	—	
3	2	.312 [7.92]	.423 [10.74]	1	85923-3	85875-8	87283-3	86207-2	85839-3	85840-3	A
4	3	.468 [11.89]	.579 [14.71]	2	85923-4	85875-1	87283-4	86207-9	85839-4	85840-4	A,C
5	4	.624 [15.85]	.735 [18.67]	2	85923-5	85875-2	87283-5	86207-3	85839-5	85840-5	A,D
6	5	.780 [19.81]	.891 [22.63]	3	85923-6	85875-9	87283-6	—	85839-6	85840-6	A,C,E
7	6	.936 [23.77]	1.047 [26.59]	3	85923-7	1-85875-0	87283-7	—	85839-7	85840-7	A,C,E
8	7	1.092 [27.74]	1.203 [30.56]	4	85923-8	1-85875-1	87283-8	—	85839-8	85840-8	A,C,E,G
9	8	1.248 [31.70]	1.359 [34.52]	3	85923-9	85875-3	87283-9	—	85839-9	85840-9	A,D,G
10	9	1.404 [35.66]	1.515 [38.48]	5	1-85923-0	1-85875-2	1-87283-0	—	1-85839-0	1-85840-0	A,C,E,G,J
11	10	1.560 [39.62]	1.671 [42.44]	4	1-85923-1	1-85875-3	1-87283-1	—	1-85839-1	1-85840-1	A,D,G,K
12	11	1.716 [43.59]	1.827 [46.41]	6	1-85923-2	85875-4	1-87283-2	—	1-85839-2	1-85840-2	A,C,E,G,J,L
13	12	1.872 [47.55]	1.983 [50.37]	4	1-85923-3	1-85875-4	1-87283-3	—	1-85839-3	1-85840-3	A,D,J,M
14	13	2.028 [51.51]	2.139 [54.33]	7	1-85923-4	1-85875-5	1-87283-4	—	1-85839-4	1-85840-4	A,C,E,G,J,L,N
15	14	2.184 [55.47]	2.295 [58.29]	5	1-85923-5	1-85875-6	1-87283-5	—	1-85839-5	1-85840-5	A,D,G,K,N
16	15	2.340 [59.44]	2.451 [62.26]	8	1-85923-6	1-85875-7	1-87283-6	—	1-85839-6	1-85840-6	A,C,E,G,J,L,N,Q
17	16	2.496 [63.40]	2.607 [66.22]	6	1-85923-7	1-85875-8	1-87283-7	—	1-85839-7	1-85840-7	A,D,G,K,N,R
18	17	2.652 [67.36]	2.763 [70.18]	7	1-85923-8	1-85875-9	1-87283-8	—	1-85839-8	1-85840-8	A,D,F,J,M,P,S
19	18	2.808 [71.32]	2.919 [74.14]	8	1-85923-9	2-85875-0	1-87283-9	—	1-85839-9	1-85840-9	B,D,F,J,L,N,Q,S
20	19	2.964 [75.29]	3.075 [78.11]	10	2-85923-0	2-85875-1	2-87283-0	—	2-85839-0	2-85840-0	A,C,E,G,J,L,N,Q,S,U
21	20	3.120 [79.25]	3.231 [82.07]	7	2-85923-1	2-85875-2	2-87283-1	—	2-85839-1	2-85840-1	A,D,G,K,N,R,U
22	21	3.276 [83.21]	3.387 [86.03]	11	2-85923-2	2-85875-3	2-87283-2	—	2-85839-2	2-85840-2	A,C,E,G,J,L,N,Q,S,U,W
23	22	3.432 [87.17]	3.543 [89.99]	8	2-85923-3	85875-5	2-87283-3	—	2-85839-3	2-85840-3	A,D,G,K,N,R,U,X
24	23	3.588 [91.14]	3.699 [93.95]	12	2-85923-4	2-85875-4	2-87283-4	—	2-85839-4	2-85840-4	A,C,E,G,J,L,N,Q,S,U,W,Y
25	24	3.744 [95.10]	3.855 [97.92]	11	2-85923-5	2-85875-5	2-87283-5	—	2-85839-5	2-85840-5	A,C,E,H,K,M,Q,S,U,W,Y

Mod I Headers, Right-Angle Post, Keyed, .031 x .062 [0.79 x 1.57] Centerline

Single Row, .156 [3.96] Centers

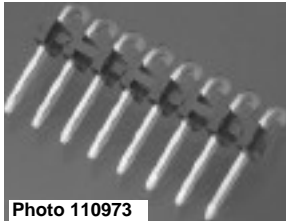

Photo 110973

Material and Finish:

Housing – Black thermoplastic, 94V-0 rated

Posts – Brass, plated as follows:

Plating A – Selectively plated .000030 [0.00076] gold on contact area, with gold flash over .000050 [0.00127] nickel on entire post

Plating B – .000015 [0.00038] gold over .000050 [0.00127] nickel on entire post

Plating C – .000100-.000200 [0.00254-0.00508] bright tin-lead over .000050 [0.00127] nickel on entire post

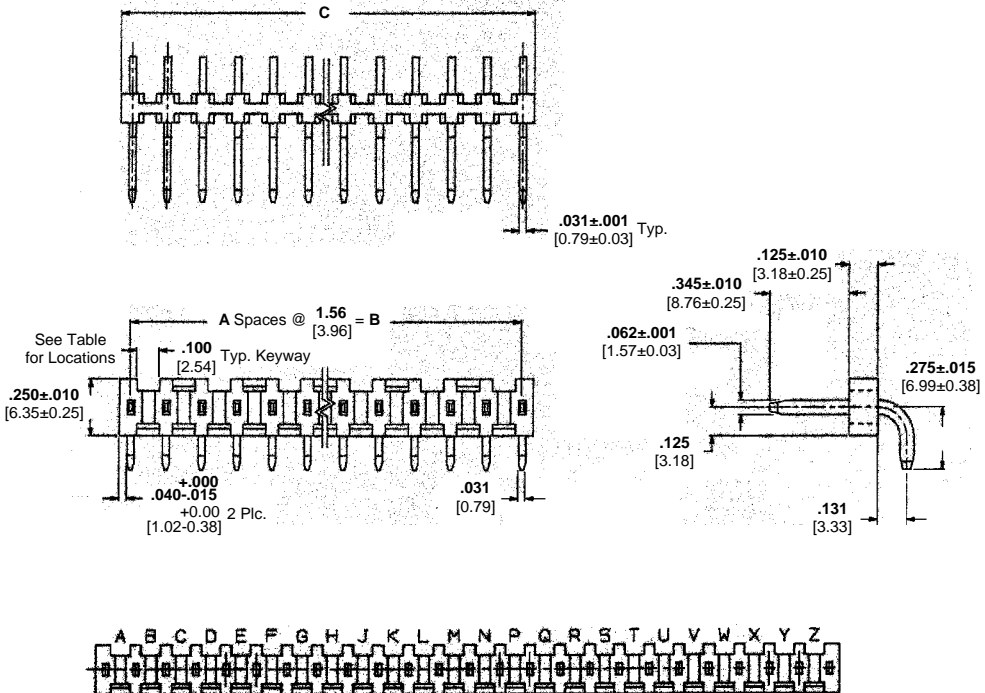

Related Product Data:

Mate with

Board Mount Receptacles—pages 303 & 304

Board Mount Receptacle Assemblies—pages 305-307

Crimp Snap-In Receptacles and Housings—pages 308-310

Locking Clip Contacts and Housings—pages 317 & 318 (see page 317 for recommended post length).

Performance Specifications—page 324

Technical Documents (page 324):

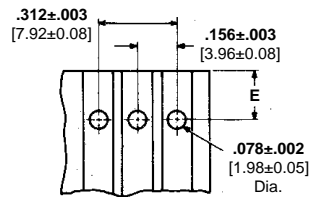

Recommended Board Layout

E Dimension

.345 [8.76] Post Height

.250 [6.35] for mounting header flush with board edge; .595 [15.11] for supporting mating connector on board.

.500 [12.70] Post Height

.250 [6.35] for mounting header flush with board edge; .750 [19.05] for supporting mating connector on board.

Keyway Locations (Ref Only)

No. of Pos.	Dimensions			No. of Keying Slots	Post Height D=.345 [8.76]		Post Height D=.500 [12.70]		Keyway Locations
	A	B	C		Plating A	Plating C	Plating B	Plating C	
2	1	.156 [3.96]	.267 [6.78]	1	87654-2	87655-2	87258-2	87194-1	A
3	2	.312 [7.92]	.423 [10.74]	1	87654-3	87655-3	87258-3	87194-2	A
4	3	.468 [11.89]	.579 [14.71]	2	87654-4	87655-4	87258-4	87194-3	A,C
5	4	.624 [15.85]	.735 [18.67]	2	87654-5	87655-5	87258-5	87194-4	A,D
6	5	.780 [19.81]	.891 [22.63]	3	87654-6	87655-6	87258-6	87194-5	A,C,E
7	6	.936 [23.77]	1.047 [26.59]	3	87654-7	87655-7	87258-7	87194-6	A,C,E
8	7	1.092 [27.74]	1.203 [30.56]	4	87654-8	87655-8	87258-8	87194-7	A,C,E,G
9	8	1.248 [31.70]	1.359 [34.52]	3	87654-9	87655-9	87258-9	87194-8	A,D,G
10	9	1.404 [35.66]	1.515 [38.48]	5	1-87654-0	1-87655-0	1-87258-0	87194-9	A,C,E,G,J
11	10	1.560 [39.62]	1.671 [42.44]	4	1-87654-1	1-87655-1	1-87258-1	1-87194-0	A,D,G,K
12	11	1.716 [43.59]	1.827 [46.41]	6	1-87654-2	1-87655-2	1-87258-2	1-87194-1	A,C,E,G,J,L
13	12	1.872 [47.55]	1.983 [50.37]	4	1-87654-3	1-87655-3	1-87258-3	1-87194-2	A,D,J,M
14	13	2.028 [51.51]	2.139 [54.33]	7	1-87654-4	1-87655-4	1-87258-4	1-87194-3	A,C,E,G,J,L,N
15	14	2.184 [55.47]	2.295 [58.29]	5	1-87654-5	1-87655-5	1-87258-5	1-87194-4	A,D,G,K,N
16	15	2.340 [59.44]	2.451 [62.26]	8	1-87654-6	1-87655-6	1-87258-6	1-87194-5	A,C,E,G,J,L,N,Q
17	16	2.496 [63.40]	2.607 [66.22]	6	1-87654-7	1-87655-7	1-87258-7	1-87194-6	A,D,G,K,N,R
18	17	2.652 [67.36]	2.763 [70.18]	7	1-87654-8	1-87655-8	1-87258-8	1-87194-7	A,D,F,J,M,P,S
19	18	2.808 [71.32]	2.919 [74.14]	8	1-87654-9	1-87655-9	1-87258-9	1-87194-8	B,D,F,J,L,N,Q,S
20	19	2.964 [75.29]	3.075 [78.11]	10	2-87654-0	2-87655-0	2-87258-0	1-87194-9	A,C,E,G,J,L,N,Q,S,U
21	20	3.120 [79.25]	3.231 [82.07]	7	2-87654-1	2-87655-1	2-87258-1	2-87194-0	A,D,G,K,N,R,U
22	21	3.276 [83.21]	3.387 [86.03]	11	2-87654-2	2-87655-2	2-87258-2	2-87194-1	A,C,E,G,J,L,N,Q,S,U,W
23	22	3.432 [87.17]	3.543 [89.99]	8	2-87654-3	2-87655-3	2-87258-3	2-87194-2	A,D,G,K,N,R,U,X
24	23	3.588 [91.14]	3.699 [93.95]	12	2-87654-4	2-87655-4	2-87258-4	2-87194-3	A,C,E,G,J,L,N,Q,S,U,W,Y
25	24	3.744 [95.10]	3.855 [97.92]	11	2-87654-5	2-87655-5	2-87258-5	2-87194-4	A,C,E,H,K,M,Q,S,U,W,Y

Wire Crimp Contacts with Insulation Support

Material and Finish:

Contact Body—Phosphor bronze, plated as follows:

Plating A—Selectively plated .000015 [0.00038] gold on contact area, with gold flash over .000050 [0.00127] nickel on entire post

Plating B—.000100 [0.00254] min. bright tin/lead over .000050 [0.00127] nickel on entire contact

Contact Spring—Stainless steel

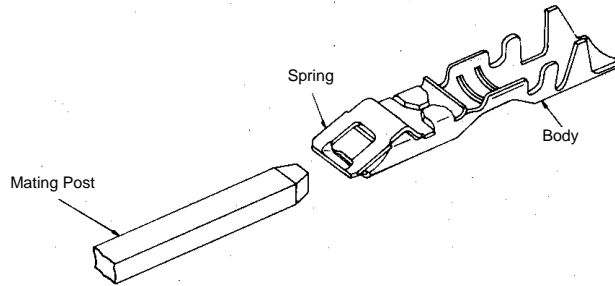

Related Product Data:

Mate with

Machine Applied Posts—page 312
 Headers (.500 Post Height Only)—pages 314-316
 (see recommended post length below)*

Housings used in—page 318

Application Tooling—pages 319-323

Performance Specification—page 324

Technical Documents (page 324):

Wire Size Range AWG [mm ²]	Ins. Dia. Range	Finish	Contact Part Nos.	
			Strip Form	Loose Piece
22-18 [0.3-0.9]	.050-.0100 [1.27-2.54]	Plating A	87269-2	87278-2
		Plating B	87269-1	87278-1

Wire Size Range AWG [mm ²]	Applicator			Premium CERTI-CRIMP Hand Tool Part Number
	Part Number	Type	Used With Machine	
22-18 [0.3-0.9]	466007-2	HDM	Model "K" (AMP-O-LECTRIC) ¹	90308-1
	466950-2	SCA	Stripper/Crimper (AMP-O-MATIC)	

¹AMP-O-LECTRIC KII Machine. Applicators also available for AMPOMATOR Lead Making Machines. Consult Tyco Electronics.

Note: These contacts must be crimped in accordance with Tyco Electronics Specification No. 114-25008 in order to function properly in a connector housing.

Extraction Tool **Part No. 91104-1** is used for removing individual contacts from connector housings and for detaching contacts from mating posts.



Photo 110999

Extraction Tool
Part No. 91104-1

Instruction Sheet 408-7678

Wire Harnessing

If necessary, wires can be grouped with cable ties and secured to a panel with fixed clamps. However, locking clip contacts must be free to float within the connector housings to allow proper extraction. Therefore, harnessing hardware or the use of multiple terminations per contact must not restrict the free-floating action of contacts in the housing. For more information, request Insulating and Bundling Products Catalog 124132.

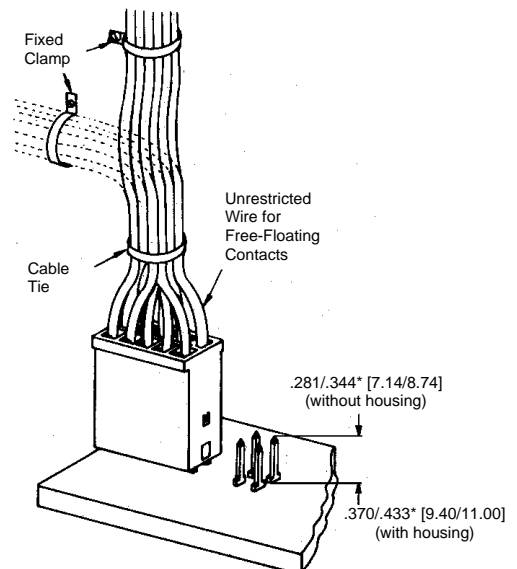

*Dimension defines .031 x .062 [0.79 x 1.57] portion of post. If post is longer than maximum specified, post tip may butt against wire ends.

Locking Clip Connector Housings, .031 x .062 [0.79 x 1.57] Centerline

Single Row, .156 [3.96] Centers

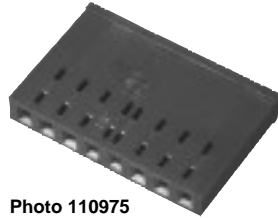

Photo 110975

Material and Finish:

Black thermoplastic, 94V-0 rated

Related Product Data

Contacts used with—page 317

Mate with

Machine Applied Posts—page 312

Headers—pages 314-316 (see page 317 for recommended post length)

Performance Specifications—page 324

Technical Documents (page 324):

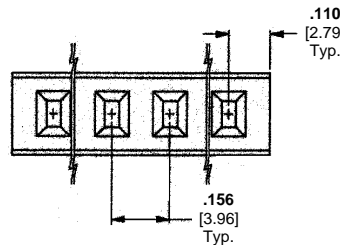
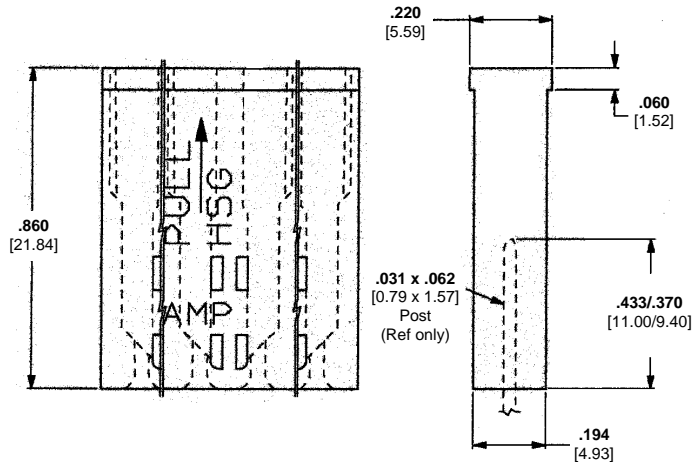
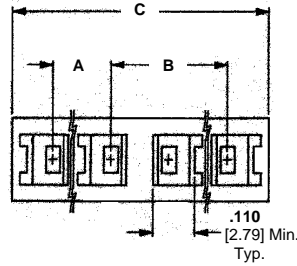

No. of Pos.	Dimensions			Housing Part Nos.		Keyed Positions on Mating Face
	A	B	C	UnKeyed	Keyed	
1	—	—	.200 [5.08]	87270-1	—	—
2	—	—	.376 [9.55]	87270-2	—	—
3	.156 [3.96]	.156 [3.96]	.532 [13.51]	1-87270-3	—	—
3 of 4	.156 [3.96]	.312 [7.92]	.688 [17.48]	—	87270-3	□□■□
4				87270-4	—	
4 of 5	.312 [7.92]	.312 [7.92]	.844 [21.44]	—	1-87270-0	□□□■□
5				1-87270-4	—	
5 of 6	.312 [7.92]	.468 [11.89]	1.000 [25.40]	—	1-87270-2	□□□□■□
6				87270-5	—	
6 of 7	.468 [11.89]	.468 [11.89]	1.156 [29.36]	—	1-87270-1	□□□□■□□
7				1-87270-5	—	
8	.468 [11.89]	.624 [15.85]	1.312 [33.32]	87270-6	—	—
9	.624 [15.85]	.624 [15.85]	1.468 [37.29]	1-87270-6	—	—
10	.624 [15.85]	.780 [19.81]	1.624 [41.25]	87270-7	—	—
11	.780 [19.81]	.780 [19.81]	1.780 [45.21]	1-87270-7	—	—
12	.780 [19.81]	.936 [23.77]	1.936 [49.17]	87270-8	—	—

■ Indicates "closed cavity". No post entry hole in this position.

Notes: 1. All housings listed above will accept Locking Clip Contacts No. 87269 and 87278, refer to page 317
2. Refer to Tyco Electronics Instruction Sheet 408-7676 for proper contact orientation within the housings.

For Crimp Snap-In Receptacles and Locking Clip Contacts

Application Tooling

Side-Feed Heavy-Duty Miniature Applicators (coded HDM)



Interchangeable applicators for crimping products reeled side-by-side on single or dual carrier strips (primarily closed-barrel terminals and open-barrel contacts). Similar design as the end-feed version. All side-feed applicators include a wire stop to help correctly position the wire end in the crimping target area.

For more information, request Instruction Sheet **408-8040**.

AMP-O-LECTRIC Model "G" Terminating Machines, 354500-1, -9, -11



Semiautomatic bench machines for crimping reeled terminals and contacts, featuring a quiet and reliable direct motor drive, microprocessor controls for ease of setup and operation, and guarding and lighting designed for operator convenience and safety. All models are equipped with either manual or automatic precision adjustment of crimp height. Machine-mounted sensors are available for crimp quality monitoring using conventional miniature-style applicators.

Specifications

Width—18.7-25.3 [475-643] depending on applicator type
Depth—21.5-28.1 [546-713] depending on applicator type
Height—20 [508]
Weight—240 lb [110 kg]
Electrical—120 or 220 VAC, 50 or 60 Hz; 310 VA
Air—90-110 psi [6.21-7.59 bar], 6 scfm [0.00282 m³/s] when required with air-feed applicators
Wire Range—26-10 AWG [0.12-6 mm²] solid or stranded, depending on product applied
 For more information, request Catalog **65828**, Video **198116**, Catalog **82275 [Crimp Quality Monitor (CQM)]**, Video **198094**.

AMPOMATOR CLS IV+ Lead-Making Machines, 356500-1, -2, 1213400-1, -2



Fully-automatic machines that measure, cut, strip and terminate single leads. Microprocessor-controlled, and programmed and operated using an easy-to-follow, menu-driven touchscreen. Features include direct-drive terminating units with precision crimp height adjustment, fully programmable setups, wire runout and splice detection, and motorized pre-feed with wire straightener. Crimp quality monitoring is also available.

Specifications

Width—159 [4 040]
Depth—68 [1 730]
Height—86 [2 185] with 24 [610] dia. reel
Weight—2 000 lb [907 kg]
Electrical—220 VAC, 50 or 60 Hz, single phase, 25 A, with neutral and ground
Air—90 psi [6.21 bar], 15 scfm [0.0071 m³/s] sustained
Wire Range—26-10 AWG [0.12-6 mm²] stranded, 26-16 AWG [0.12-1.4 mm²] solid
Lead Lengths—3-90 [76.2-2 285], 90-1 000 [2 285-25 400] with long lead conveyors
 For more information, request Catalog **124324**, Video **198142 (NTSC)**, **199609 (PAL)**.

Note: For additional tooling options, contact Tyco Electronics or reference the Tyco web site.

For Crimp Snap-In Receptacles and Locking Clip Contacts (Continued)

Application Tooling (Continued)

AMP-O-MATIC Stripper-Crimper Machines, 854040-3, -4



Semiautomatic bench crimping machines that also strip the wire, and are therefore used for terminating jacketed cable. Feature manual precision adjustment of crimp height, keyed strip blades for faster, more accurate setups, and an efficient scrap removal system. All adjustments can be made from the front of the machines without special tools. Available with crimp quality monitoring.

Specifications

Width—14 [355]

Depth—18 [457]

Height—33 [838] without reel

Weight—150 lb [68 kg]

Electrical—120 VAC, 50 or 60 Hz, .5 A

Air—80-100 psi [5.52-6.90 bar], 3.5 scfm [0.00165 m³/s]

Wire Range—32-14 AWG [0.03-2 mm²]

For more information, request Catalog **65004**, Video **198075**, Catalog **82275 [Crimp Quality Monitor (CQM)]**, Video **198094**.

Stripper-Crimper Applicators (coded SCA)

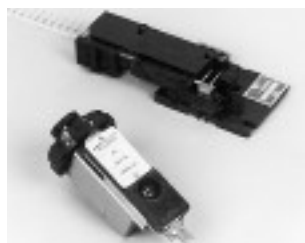

Interchangeable applicators for crimping products in AMP-O-MATIC Stripper-Crimper Machines. Consist of separate ram and lower tooling assemblies. Similar dial-in settings for different wire sizes and insulation diameters as HDM applicators. Available with sensors for use with the Crimp Quality Monitor.

For more information, request Catalog **65004 (AMP-O-MATIC Stripper-Crimper Machines)**, Catalog **82275 [Crimp Quality Monitor (CQM)]**.

Kappa 235, Automatic Cut and Strip, 3-547178-1



The Kappa 235 has the capability of processing wires with a cross section of up to 4 AWG and an outside diameter of 0.59 inch. Options include an inner conductor processing kit for multiconductor cables and a flat ribbon cable kit.

Specifications

Width—25 [630]

Depth—16 [490]

Height—13.4 [370]

Weight—95 lb [44 kg]

Wire Cross-Sections—24-4 AWG [0.22-25 mm²]

Flat Ribbon Cables—width up to 40mm

Length Range—0.04"-328ft [1mm - 99.99m] (+/- 0.2%)

Electrical—110/230 V - 50/60Hz, switches automatically

For more information, request Catalog **1307776**.

Note: For additional tooling options, contact Tyco Electronics or reference the Tyco Electronics web site.

**For Crimp Snap-In
Receptacles and Locking
Clip Contacts** (Continued)**Application Tooling** (Continued)**CERTI-CRIMP Straight
Action Hand Tools (SAHT)**

Premium grade hand tools. Feature ratchet control to provide complete crimp cycle. Die sets close in a straight line. Include a contact locator and wire stop, plus an insulation crimp adjustment lever, when applicable. Approximate weight 1.3 lb [0.59 kg]

For more information, request Catalog **65780**.

**PRO-CRIMPER II
Hand Tool**

Commercial grade hand tool for crimping various products. Features ratchet control to provide complete crimp cycle. Accepts both pinned- and shouldered-style die sets. Locators are provided with pinned-style die sets for proper contact and wire positioning, and to help minimize contact rotation and bending during crimping. Approximate weight 1.3 lb [0.60 kg].

For more information, request Catalog **82276**, Instruction Sheet **408-9930**.

Note: For additional tooling options, contact Tyco Electronics or reference the Tyco Electronics web site.

Application Tooling (Continued)

For Board Mount Receptacles and Machine Applied Posts

Modular Insertion System (MIS) Bench Machines, 217600 Series, 662820 Series (shown)



For Board Mount Receptacles

Bench machines for inserting a variety of products into pc boards. Uses the same interchangeable insertion heads as the Comp-U-Sertor II Machines. Series 217600 machines feature a manually-operated X-Y positioning fixture, plus a locator spotlight. The machine cycles when the board hole is placed on the anvil and both triggers on the dual handles attached to the X-Y fixture are depressed. Series 662820 machines, without board fixturing, cycle automatically when the hole is properly located. A stabilizing disk over the anvil helps keep the board level.

Specifications

- Width**—18 [457]
 - Depth**—24 [610]
 - Height**—18 [457]
 - Weight**—250 lb [113 kg]
 - Electrical**—120 to 220 VAC, 50 or 60 Hz (217600); 120 or 240 VAC, 60 Hz, single phase, 120 VA (662820)
 - Air**—80 psi [5.52 bar] min., 15 scfm [0.00708 m³/s] min.
 - Insertable Area**—18 x 22 [457 x 559] max.
- For more information, request Catalog **296059**.

This benchtop insertion machine installs contacts into PC boards at rates to 2000 per hour. A spotlight highlights the insertion area, and lower tooling assures precise board location. The machine is activated by a foot pedal.

Comp-U-Sertor II Machines, 122300-1, -2



Microprocessor-controlled X-Y positioning table for inserting a variety of products into pc boards, including .025² stamped or bandoliered posts, mini-spring sockets, and FASTON tabs. Insertion heads for the different products are interchangeable, and may also be used with bench machines. Controlled, programmed and operated using an interactive touchscreen. Options include double-action clinch tooling, powered dereeler, splice run-out detector, take-up winder for paper tape, and scrap chopper.

Specifications

- Width**—58 [1 473]
 - Depth**—66 [1 676] with reel
 - Height**—63 [1 600]
 - Weight**—500 lb [227 kg]
 - Electrical**—120 VAC, 50 or 60 Hz (122300-1); 220 VAC, 50 or 60 Hz (122300-2); 1 800 VA
 - Air**—80 psi [5.52 bar] min., 15 scfm [0.00708 m³/s] min.
 - Insertable Area**—12 x 18 [305 x 457] max.
- For more information, request Catalog **296059**.

Note: For additional tooling options, contact Tyco Electronics or reference the Tyco Electronics web site.

Application Tooling (Continued)**For Board Mount
Receptacles and Machine
Applied Posts** (Continued)**P300 Automatic Insertion
Machine**

Automatic machine for inserting a variety of contacts into pc boards (PCBs). Equipped with an insertion tool (comprised of a product-specific insertion head, an anvil, and a product feed mechanism). Stepper-motor driven X-Y table positions PCBs under insertion head. Surface Mount Equipment Manufacturers Association (SMEMA) compatible inline PCB Insertion Station for posts, tabs, receptacles or sockets. Stand-alone unit is field upgradeable to Pass Through. Mounts up to four AMP pneumatic insertion heads. Modem diagnostics standard, vision system optional. Control panel used to program and monitor entire insertion process.

Specifications**Width**—57.5 [1 460]**Depth**—64.5 [1 640]**Height**—60 [1 520]**Weight**—Depending on configuration**Electrical**—110 V, 60 Hz**Air**—87 psi [6 bar]**Insertable Area**—24 x 16 [600 x 400]

For more information, contact Tyco Electronics.

The electrical, mechanical and environmental characteristics of the AMPMODU .031 x .062 [0.79 x 1.57] Interconnection System are listed below:

Performance Specifications

Mechanical Characteristics

Contact Durability:

Plating	Receptacles		Locking Clip Contacts
	Standard Pressure	High Pressure	
.000016 [0.00041] Min. Tin	75 Cycles	25 Cycles	N/A
.000079 [0.00201] Min. Tin	75 Cycles	25 Cycles	N/A
.000100 [0.00254] Min. Bright Tin/Lead	N/A	N/A	25 Cycles
.000015 [0.00038] Gold	75 Cycles	50 Cycles	25 Cycles
.000030 [0.00076] Gold	200 Cycles	100 Cycles	N/A

Electrical Characteristics

Contact Current Rating:

5 amperes max. for single contact in free air, could vary due to ambient temperature, wire size and duty cycles.

Contact Resistance:

12 milliohms at 100 ma and 50 mv open circuit.

Dielectric Rating:

At Sea Level – 1200 VAC between contacts on .156 [3.96] centers for 1 minute.

Insulation Resistance: 5 x 10³ megohms (initial)

Connector Durability

Receptacles

Mating – 16 oz. [4.45N] max. per contact after 3 mating cycles (standard pressure)

–30 oz. [8.34N] max. per contact after 3 mating cycles (high pressure, gold)

–60 oz. [16.68N] max. per contact after 3 mating cycles (high pressure, tin)

Unmating – 1 oz. [0.28N] min. per contact after 3 mating cycles (standard pressure)

3 oz. [0.83N] min. per contact after 3 mating cycles (high pressure)

Locking Clip Contacts

Mating – 4 lb. [17.79N] max. per contact after 3 mating cycles

Unmating – 2 lb. [8.90N] min. per contact after 3 mating cycles

Environmental Characteristics

Operating Temperature: -65°C to 105°C [-85°F to 221°F] (Gold Plated)

-65°C to 60°C [-85°F to 140°F] (Tin Plated)

Technical Documents

Various technical documents are available for your use:

Product Specifications

describe technical performance characteristics and verification tests. They are intended for the Design, Component and Quality Engineer.

108-25016 Interconnection System, Standard Pressure

108-25025 Interconnection System, High Pressure, Gold

108-25025-1 Interconnection System, High Pressure, Tin

108-36029 Locking Clip Connectors

Application Specifications

describe requirements for using the product in its intended application and/or crimping information. They are intended for the Packaging and Design Engineer and the Machine Setup Person.

114-25000 Crimp Snap-In Receptacle Contacts

114-25004 Board Mount Receptacle Contacts

114-25008 Locking Clip Contacts

114-25011 Machine Applied Straight Posts

Instruction Sheets provide instructions for assembling or applying the product. They are intended for the Manufacturing Assembler or Operator.

408-7308 Clinching Procedures for Header Assemblies

408-7411 Suggestions for Wave Soldering AMPMODU Receptacles

408-7594 AMP Hand Tool 90274-2 for Crimping Crimp Snap-In 18-22 AWG Contacts

408-7750 AMP Hand Tool 90328-1 for Crimping Crimp Snap-In Contacts (22-26 AWG)

408-7676 AMPMODU Locking Clip Connectors and Contacts

408-7671 AMP Hand Tool 90308-1 for Crimping Locking Clip Contacts

408-7678 AMP Extraction Tool 91104-1 for Locking Clip Contacts

408-7981 Clinching Procedures for Receptacle Assemblies

408-9451 AMP Extraction Tool 843473-1 for Crimp Snap-In Receptacles