

© COPYRIGHT 1978 BY AMP INCORPORATED, HARRISBURG, PA. ALL INTERNATIONAL RIGHTS RESERVED. AMP INCORPORATED PRODUCTS COVERED BY U. S. AND FOREIGN PATENTS AND/OR PATENTS PENDING.

REVISIONS					
P	F	ZONE	LTR	DESCRIPTION	DATE APPROVED
			O	RELEASE	
A			A	REVISED PER ECN 2481	2/28/78 JH
B			B1	REV ECN 202	11-18-81 EGE
B			B	REV ECN 278	10/29/84 JH
B			B1	REV ECN 1863	10/10/88 SB
C			C	REV LOC & DIST AD-4171	11-29-89 BE
D			D	REV ECN AD-4835	8-25-90 JPC
E			E	REV PER 0010-1103-92	3-15-94 EGE
F			F	REV PER 0010-1125-94	12-14-94 JH
G			G	REV PER 0030-0026-00	11-9-98 MZ

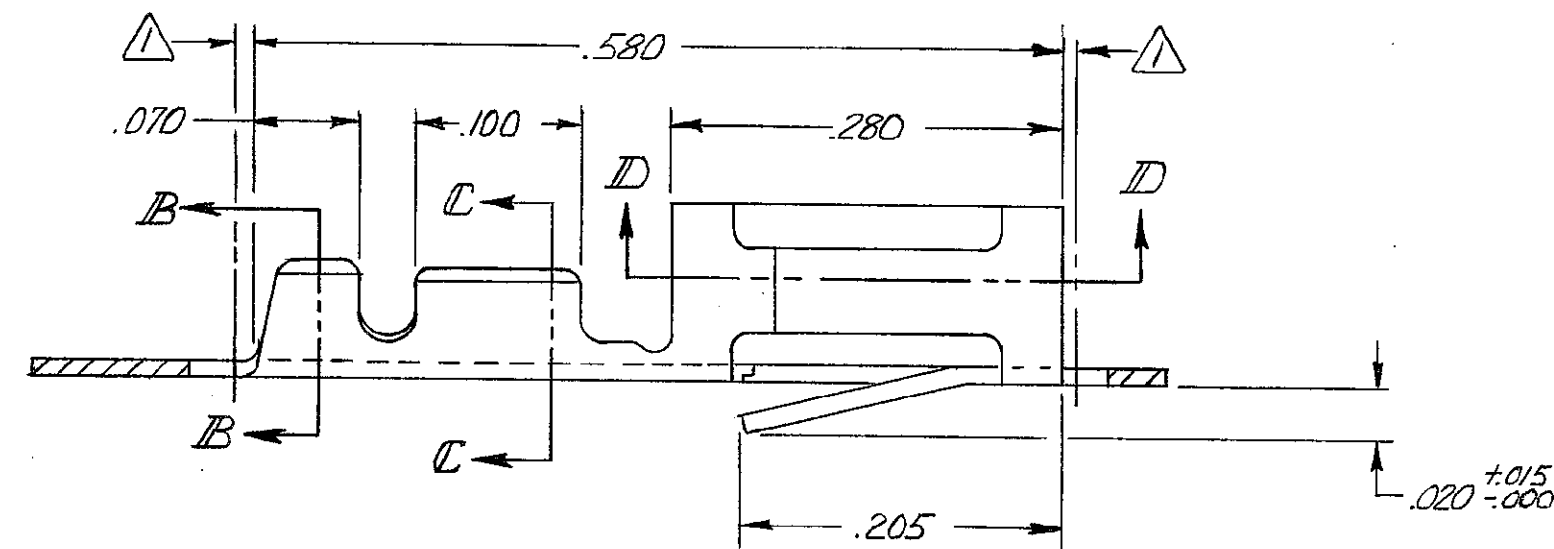

- 1. .010 MAX CUT-OFF TAB FOR LOOSE PIECE.
- 2. GOLD FLASH OVER .000050 NICKEL ENTIRE CONTACT, .000015 GOLD ON CONTACT AREA
- 3. GOLD FLASH OVER .000050 NICKEL ENTIRE CONTACT .000030 GOLD ON CONTACT AREA.
- 4. .000016 MIN TIN.
- 5. LUBRICATED
- 6. POINT OF MEASUREMENT FOR PLATING THICKNESS.
- 7. .000015 GOLD ON CONTACT AREA, .000050-.000100 BRIGHT TIN-LEAD ON TERMINATION AREA, ALL OVER .000050 NICKEL ENTIRE TERMINAL.
- 8. .000030 GOLD ON CONTACT AREA, .000050-.000100 BRIGHT TIN-LEAD ON TERMINATION AREA, ALL OVER .000050 NICKEL ENTIRE TERMINAL.
- 9. OBSOLETE PART NUMBER.

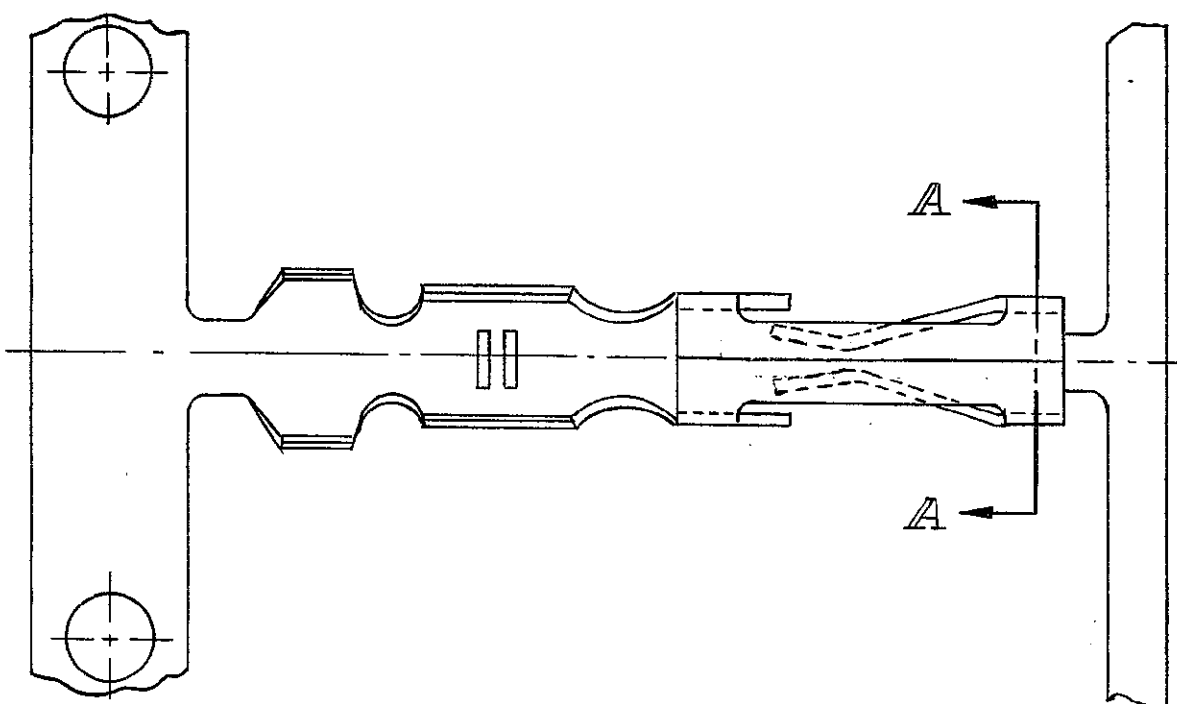
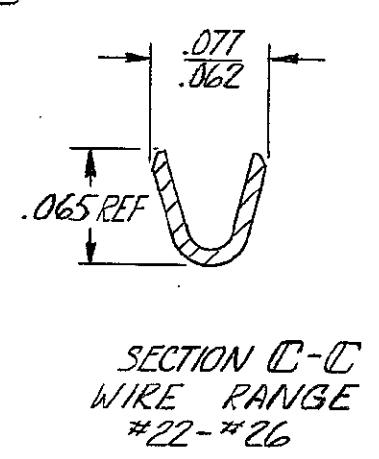
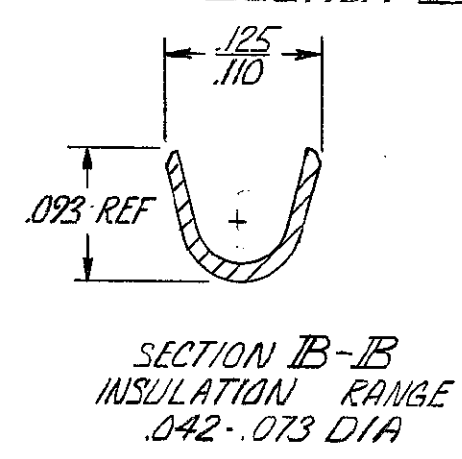
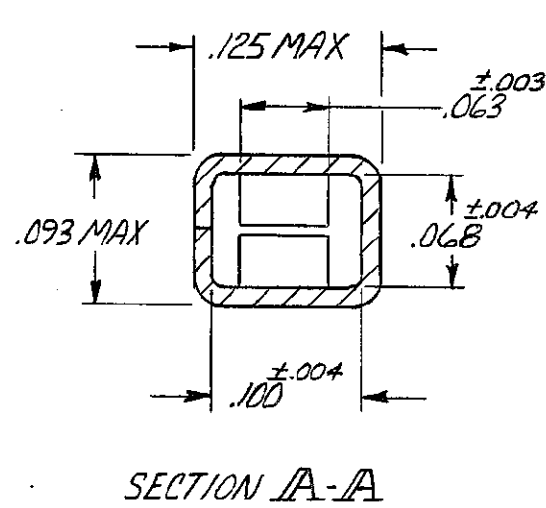
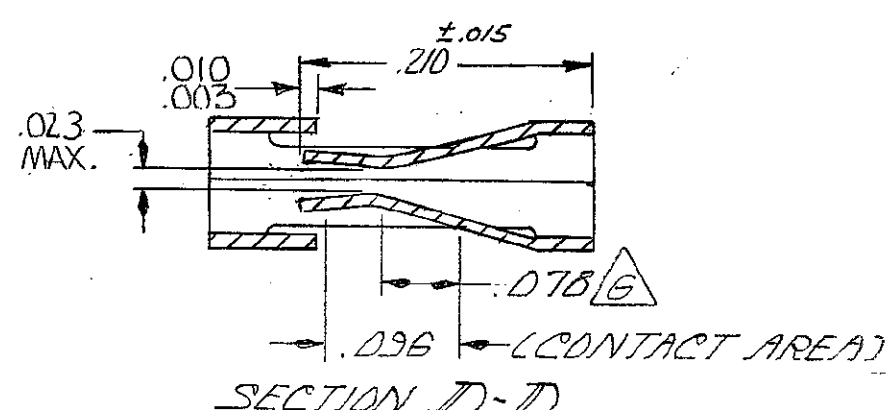
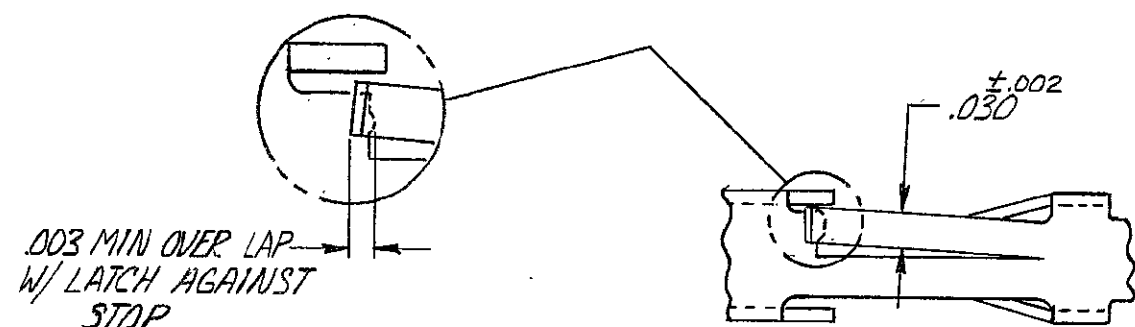

8	9	102106-5	102102-7	
7	9	102106-4	102102-6	
4	5	9	102106-3	102102-5
3		102106-2	102102-2	
2	9	102106-1	102102-1	
FINISH	LOOSE PIECE P/N	PART NO		

UNLESS OTHERWISE SPECIFIED DIMENSIONS ARE IN INCHES. TOLERANCES ON: DECIMALS ± .005 ANGLES ±		CONTRACT NO		AMP INCORPORATED Harrisburg, Pa.	
MATERIAL PHOS. BRONZE		DR H. Berlin 4-12-78		NAME CONTACT, MOD I, RECEPTACLE, CRIMP SNAP-IN, HIGH PRESSURE, #22 - #26 AWG, SIDE FEED	
FINISH SEE TABLE		CHK B. Wolfe 4-27-78		SIZE CODE IDENT NO DRAWING NO C 00779 102102	
		APPD G. Zimmerman 4/28/78		SCALE	
		APPD Bennett 5/1/78		SHEET	