

THIS DRAWING IS UNPUBLISHED. RELEASED FOR PUBLICATION
 © COPYRIGHT - By - ALL RIGHTS RESERVED.

LOC	DIST	REVISIONS					
GP	00	P	LTR	DESCRIPTION	DATE	DWN	APVD
			H	REVISED PER ECO-13-000728	21FEB2013	BMM	SLB

- NOTES:
- MATERIAL**
 HOUSING : THERMOPLASTIC, UL94V-0, BLACK
 CONTACTS : BRASS.
 SHELL : STEEL
 SCREW : BRASS.
 BOARD LOCK : BRASS.
 SCREW OF TORQUE : 5 Kg-cm MAX.
 - FINISH**
 CONTACT : 15µ" MIN.GOLD PLATING ON CONTACT AREA
 100µ" MIN. TIN
 PLATING ON SOLDERTAILS
 SHELL : 50µ" MIN. NICKEL UNDERPLATED OVERALL
 60µ" MIN. TIN PLATING
 SCREW : 50µ" MIN. NICKEL PLATING.
 BOARD LOCK : 50µ" MIN. NICKEL PLATING.
 - CHARACTERISTICS**
 CURRENT RATING : 3A
 INSULATION RESISTANCE : 1000MOHMS MIN, 500VDC FOR 2MINS.
 TEMPERATURE RATING : -55DEGC ~ +105DEGC
 VOLTAGE RATING : 250VDC

△ OBSOLETE PARTS: OBSOLETE CIS STREAMLINING PER D.RENAUD/D.SINISI

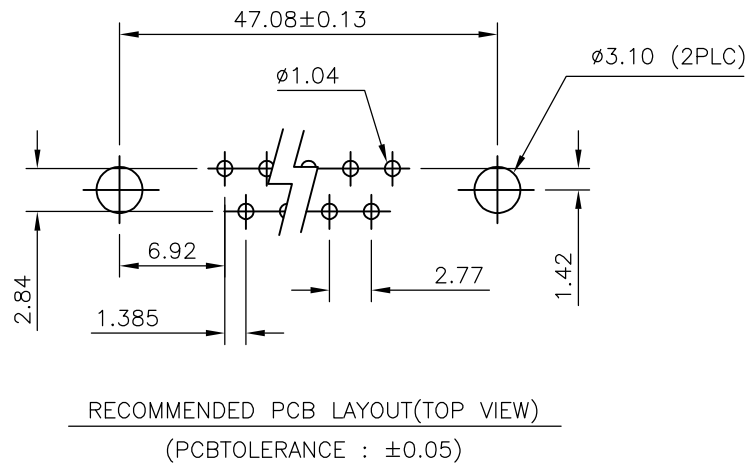
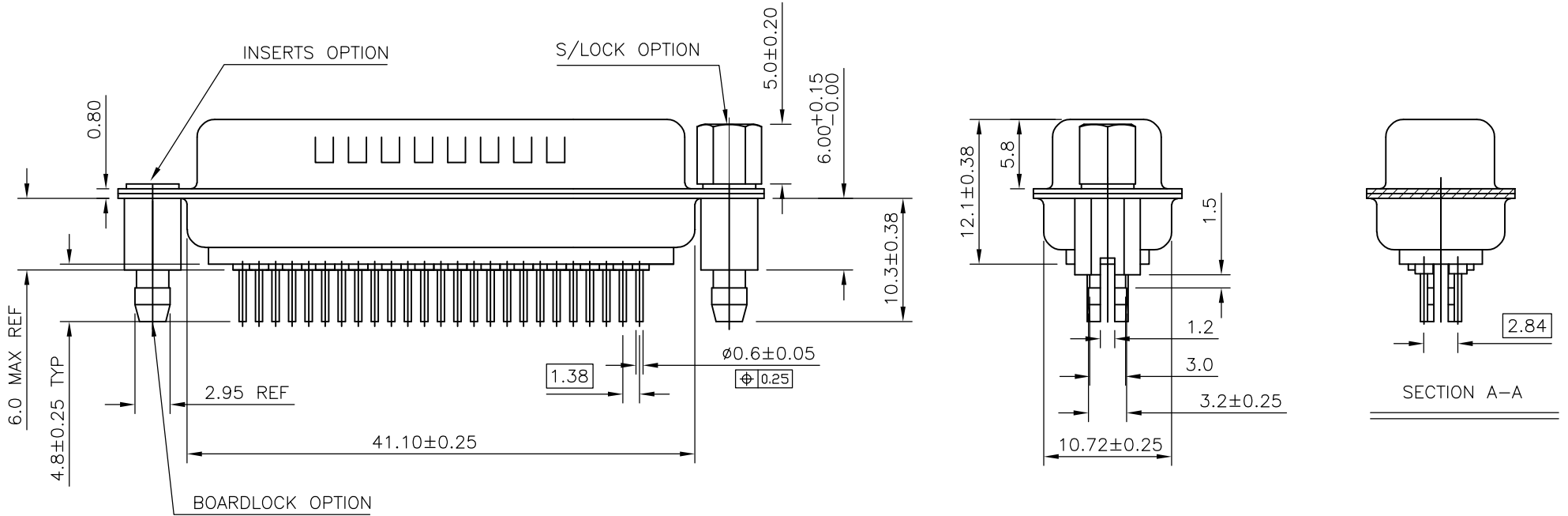
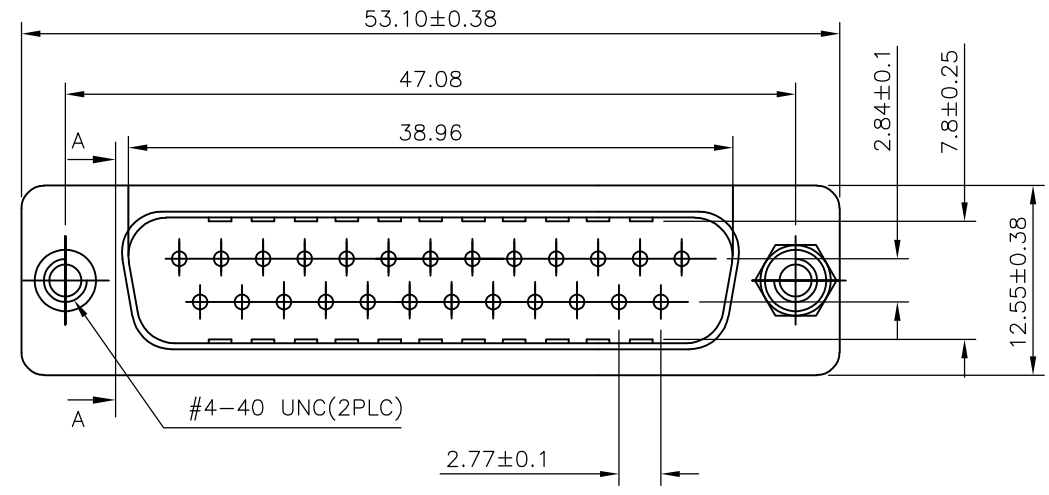

△ OBSOLETE	25W D PLG WITH B/L & M3 S/LOCK 15µ" GOLD	4-1634220-2
	25W D PLG WITH B/L & 4-40 S/LOCK 15µ" GOLD	3-1634220-2
△ OBSOLETE	25W D PLG WITH B/L & M3 INSERTS 15µ" GOLD	2-1634220-2
	25W D PLG WITH B/L & 4-40 INSERTS 15µ" GOLD	1-1634220-2
	DESCRIPTION	PART No.

THIS DRAWING IS A CONTROLLED DOCUMENT. DIMENSIONING AND TOLERANCING PER ASME Y14.5M-2009		DWN	J.SANDWELL	10APR03	 TE Connectivity NAME D-SUB HD20, VERTICAL, 25P PLUG CONNECTOR	
DIMENSIONS: MM		CHK	R.DYER	10APR03		
TOLERANCES UNLESS OTHERWISE SPECIFIED:		APVD	F.WHEELER-KING	10APR03		
0 PLC ± - 1 PLC ± 0.25 2 PLC ± .15 3 PLC ± - 4 PLC ± - ANGLES ± 3		PRODUCT SPEC	-	-		
MATERIAL		FINISH	-	-	APPLICATION SPEC	-
		WEIGHT	-	-	SIZE	A3
		CUSTOMER DRAWING			CAGE CODE	00779
					DRAWING NO	C-1634220
					RESTRICTED TO	-
					SCALE	2:1
					SHEET	1 OF 2
					REV	H

THIS DRAWING IS UNPUBLISHED.

RELEASED FOR PUBLICATION

ALL RIGHTS RESERVED.

© COPYRIGHT - By -

LOC GP DIST 00

REVISIONS

P	LTR	DESCRIPTION	DATE	DWN	APVD
-	-	SEE SHEET 1	-	-	-

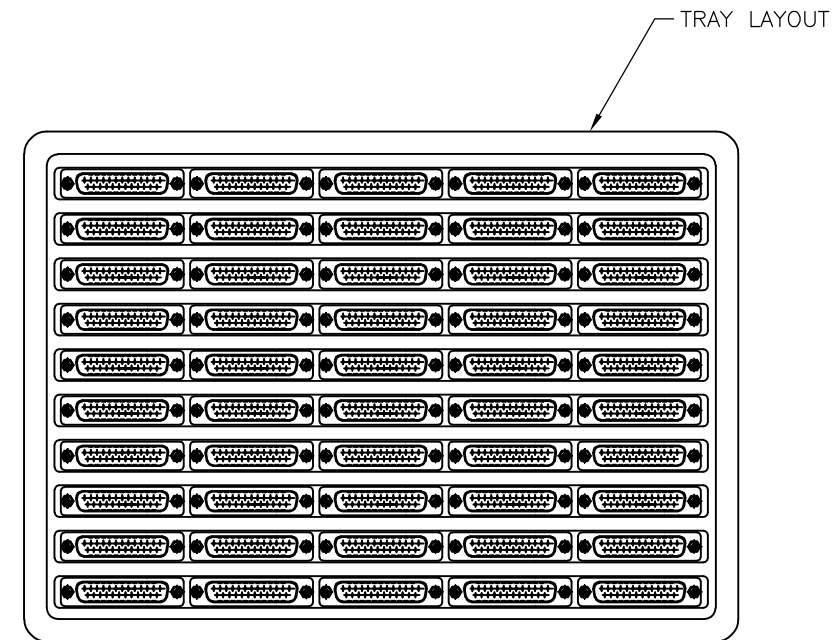
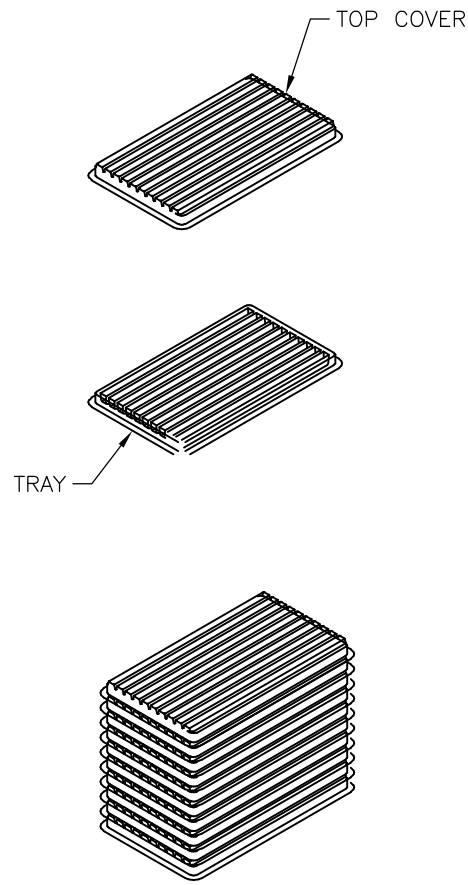

NOTES:

MATERIAL

- 1. TRAY: PVC
- 2. SHIPPING CARTON: CORRUGATED FIBERBOARD

DIMENSIONS

- 1. TRAY: L=310, W=230, H=21
- 2. SHIPPING CARTON: L=330, W=245, H=160

QUANTITY

- 50 PCS/TRAY
- 10 TRAY/SHIPPING CARTON

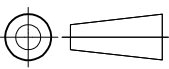
THIS DRAWING IS A CONTROLLED DOCUMENT. DIMENSIONING AND TOLERANCING PER ASME Y14.5M-2009		DWN J.SANDWELL 10APR03	 TE Connectivity			
DIMENSIONS: MM 		CHK R.DYER 10APR03				NAME D-SUB HD20, VERTICAL, 25P PLUG CONNECTOR
TOLERANCES UNLESS OTHERWISE SPECIFIED: 0 PLC ± - 1 PLC ± 0.25 2 PLC ± .15 3 PLC ± - 4 PLC ± - ANGLES ± 3		APVD F.WHEELER-KING 10APR03	SIZE A3			
MATERIAL -		PRODUCT SPEC -				CAGE CODE 00779
FINISH -		APPLICATION SPEC -	WEIGHT -	SCALE 2:1	SHEET 2 OF 2	REV H
CUSTOMER DRAWING						