

THIS DRAWING IS UNPUBLISHED.

RELEASED FOR PUBLICATION APR ,2003.

LOC GP DIST 00

REVISIONS

© COPYRIGHT 2003 By -

ALL RIGHTS RESERVED.

P	LTR	DESCRIPTION	DATE	DWN	APVD
G		REVISED PER ECO-12-014716	23AUG2012	CJV	SLB

NOTES:

- MATERIAL**
 HOUSING : THERMOPLASTIC, UL94V-0, BLACK
 CONTACTS : PHOSPHOR BRONZE.
 SHELL : STEEL.
 SCREW : BRASS.
 BOARD LOCK : BRASS
 SCREW OF TORQUE : 5 Kg-cm MAX.
- FINISH**
 CONTACT : 15µ" MIN. GOLD PLATING ON CONTACT AREA
 100µ" MIN. TIN PLATING ON SOLDER TAILS
 50µ" MIN. NICKEL UNDERPLATED OVERALL
 SHELL : 60µ" MIN. TIN PLATING
 SCREW: 50µ" MIN. NICKEL PLATING.
 BOARD LOCK : 50µ" MIN. NICKEL PLATING.
- CHARACTERISTICS**
 CURRENT RATING : 3A
 INSULATION RESISTANCE : 1000MOHMS MIN, 500VDC FOR 2MINS.
 TEMPERATURE RATING : -55DEGC ~ +105DEGC
 VOLTAGE RATING : 250VDC

⚠️ OBSOLETE PARTS: OBSOLETE CIS STREAMLINING PER D.RENAUD/D.SINISI

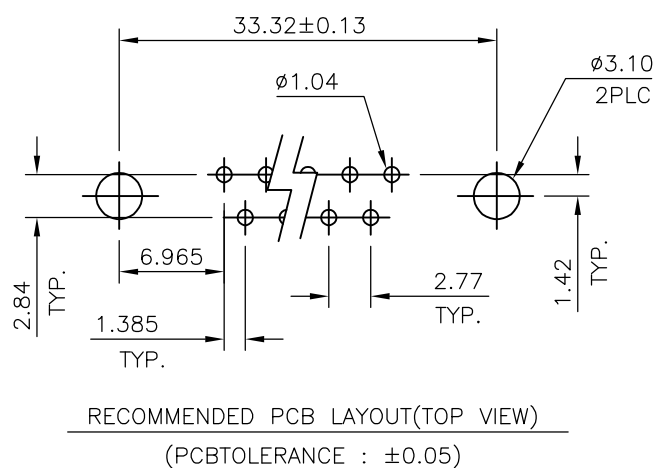
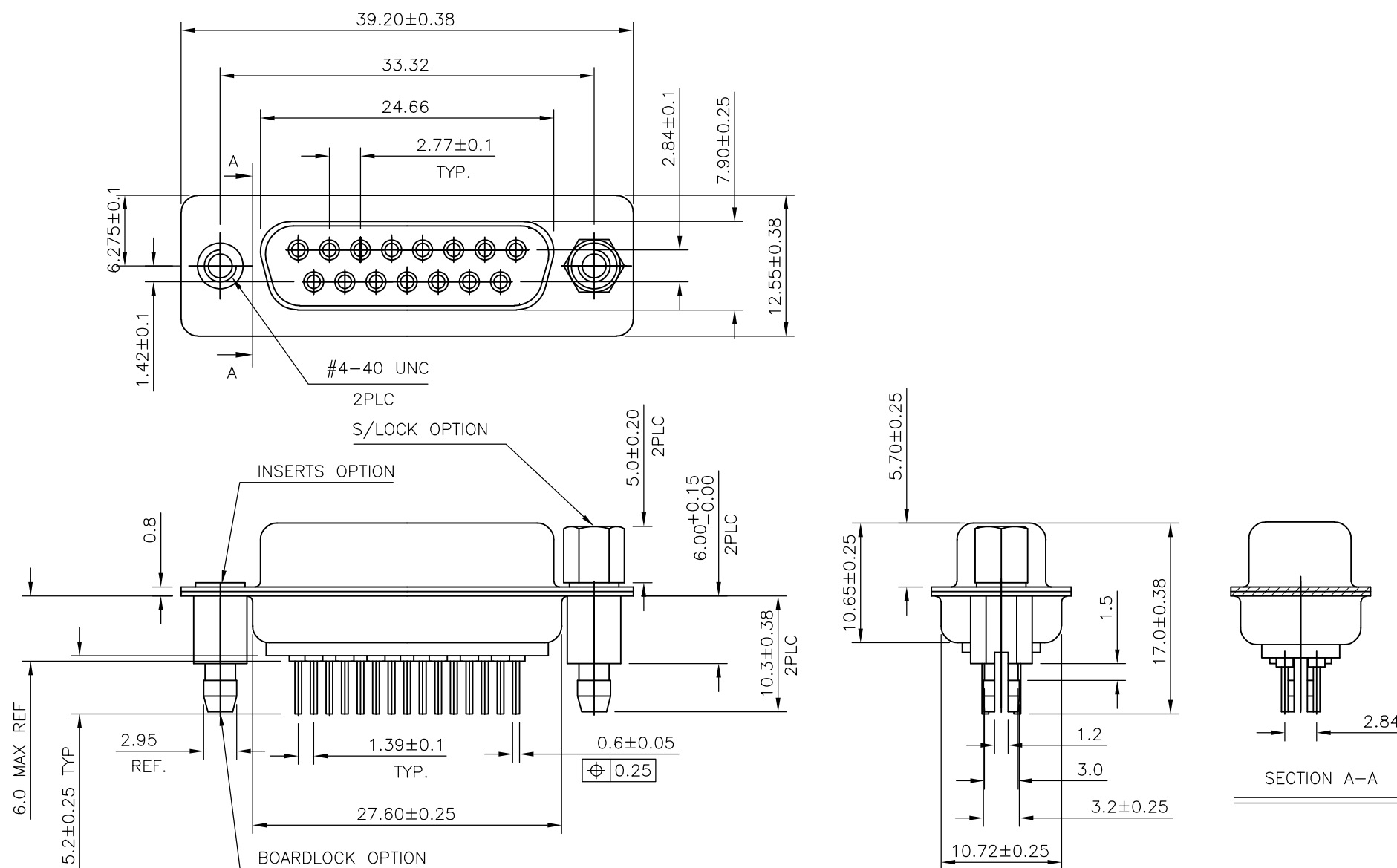

DESCRIPTION	TE PART No.
15W D SKT WITH B/L & M3 S/LOCK 15µ" GOLD	4-1634223-2
15W D SKT WITH B/L & 4-40 S/LOCK 15µ" GOLD	3-1634223-2
15W D SKT WITH B/L & M3 INSERTS 15µ" GOLD	2-1634223-2
15W D SKT WITH B/L & 4-40 INSERTS 15µ" GOLD	1-1634223-2

THIS DRAWING IS A CONTROLLED DOCUMENT. DIMENSIONING AND TOLERANCING PER ASME Y14.5M-2009		DWN J.SANDWELL 10APR03	STE TE Connectivity	
DIMENSIONS: MM		CHK R.DYER 10APR03		
TOLERANCES UNLESS OTHERWISE SPECIFIED:		APVD F.WHEELER-KING 10APR03	NAME	
0 PLC ± -	1 PLC ± 0.25	PRODUCT SPEC -	D-SUB HD20, VERTICAL, 15P SKT CONNECTOR	
2 PLC ± 0.15	3 PLC ± -	APPLICATION SPEC -	SIZE	CAGE CODE
4 PLC ± -	ANGLES ± -	WEIGHT -	A3	00779
MATERIAL -	FINISH -	DRAWING NO		RESTRICTED TO
		G-1634223		-
		CUSTOMER DRAWING		SCALE 2:1
		SHEET 1 OF 2		REV G

THIS DRAWING IS UNPUBLISHED.

RELEASED FOR PUBLICATION APR , 2003.

© COPYRIGHT 2003 By -

ALL RIGHTS RESERVED.

LOC	DIST	REVISIONS					
GP	00	P	LTR	DESCRIPTION	DATE	DWN	APVD
		-		SEE SHEET 1	-	-	-

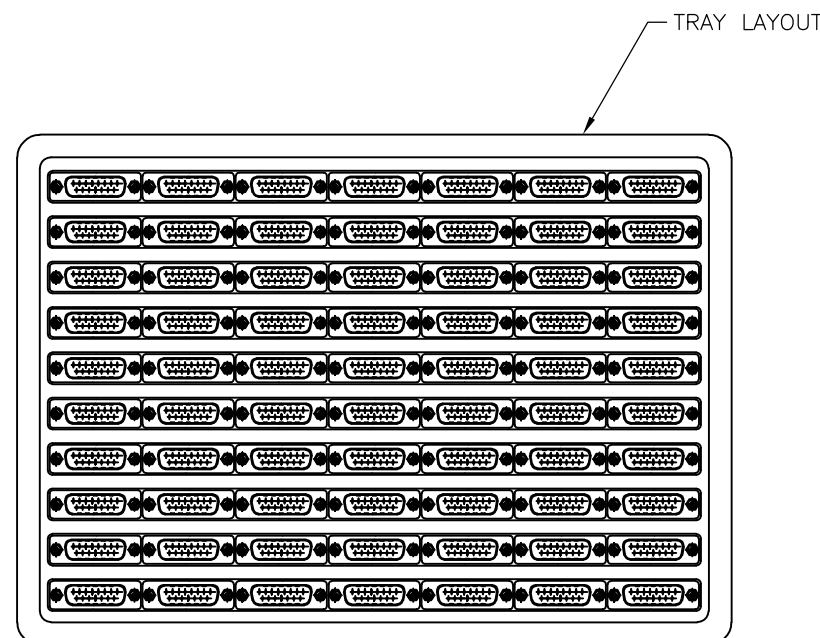
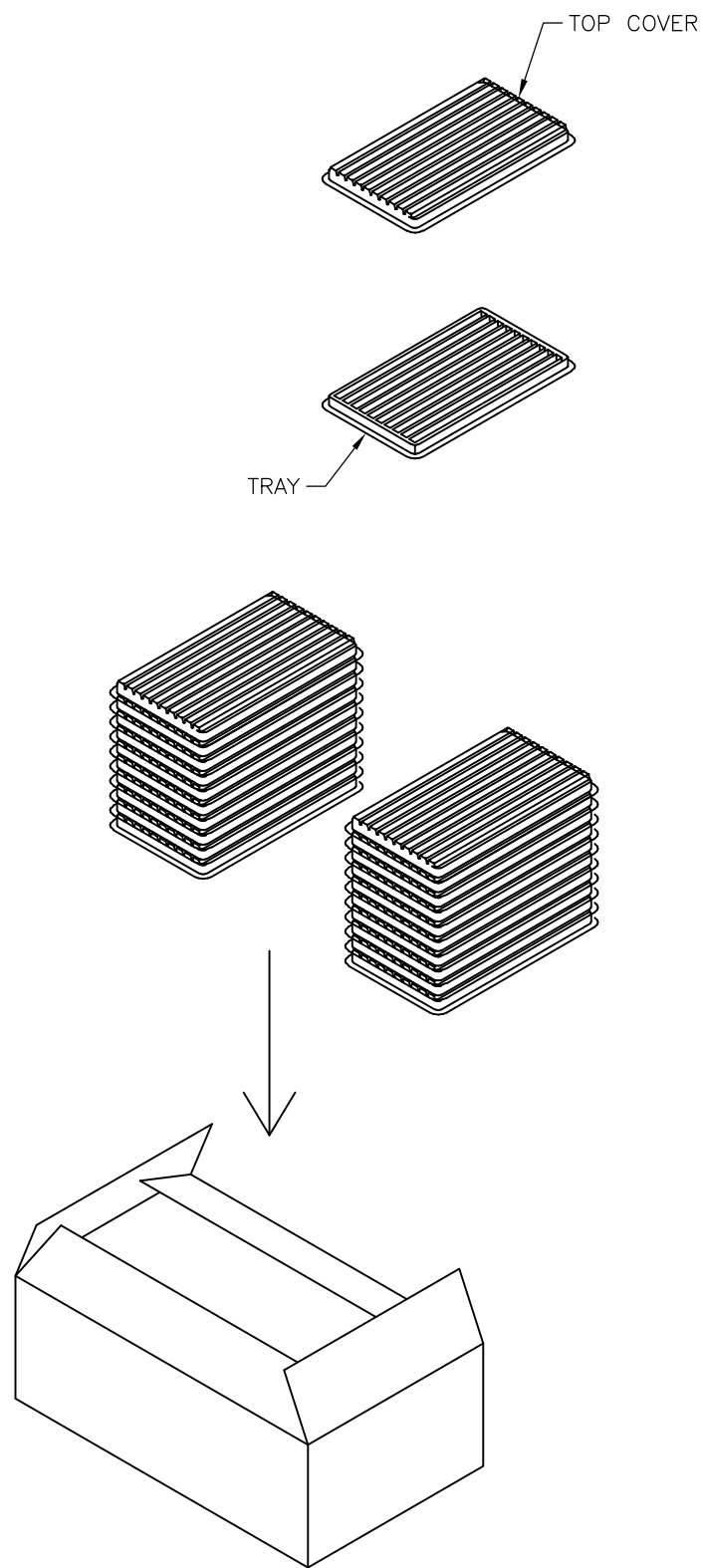

NOTES:

MATERIAL

- 1. TRAY: PVC
- 2. SHIPPING CARTON: CORRUGATED FIBERBOARD

DIMENSIONS

- 1. TRAY: L=310, W=230, H=21
- 2. SHIPPING CARTON: L=330, W=245, H=160

QUANTITY

- 70 PCS/TRAY
- 10 TRAY/SHIPPING CARTON

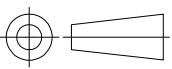
THIS DRAWING IS A CONTROLLED DOCUMENT. DIMENSIONING AND TOLERANCING PER ASME Y14.5M-2009		DWN J.SANDWELL 10APR03	 TE Connectivity D-SUB HD20, VERTICAL, 15P SKT CONNECTOR				
DIMENSIONS: MM		CHK R.DYER 10APR03				NAME	
		APVD F.WHEELER-KING 10APR03				D-SUB HD20, VERTICAL, 15P SKT CONNECTOR	
TOLERANCES UNLESS OTHERWISE SPECIFIED:		PRODUCT SPEC				-	
0 PLC ± -		APPLICATION SPEC	-				
1 PLC ± 0.25		WEIGHT	-				
2 PLC ± 0.15		SIZE CAGE CODE DRAWING NO			RESTRICTED TO		
3 PLC ± -		A3 00779 C-1634223			-		
4 PLC ± -		CUSTOMER DRAWING			SCALE 2:1 SHEET 2 OF 2 REV G		
ANGLES ± -							
FINISH							
MATERIAL							