

THIS DRAWING IS UNPUBLISHED. RELEASED FOR PUBLICATION. ALL RIGHTS RESERVED.

LOC		DIST		REVISIONS			
P	LTR	DESCRIPTION		DATE	DWN	APVD	
AF	50	B2	REL PER ECR 11-022490	04NOV11	JR	JH	

# SUGGESTED MATING TAB

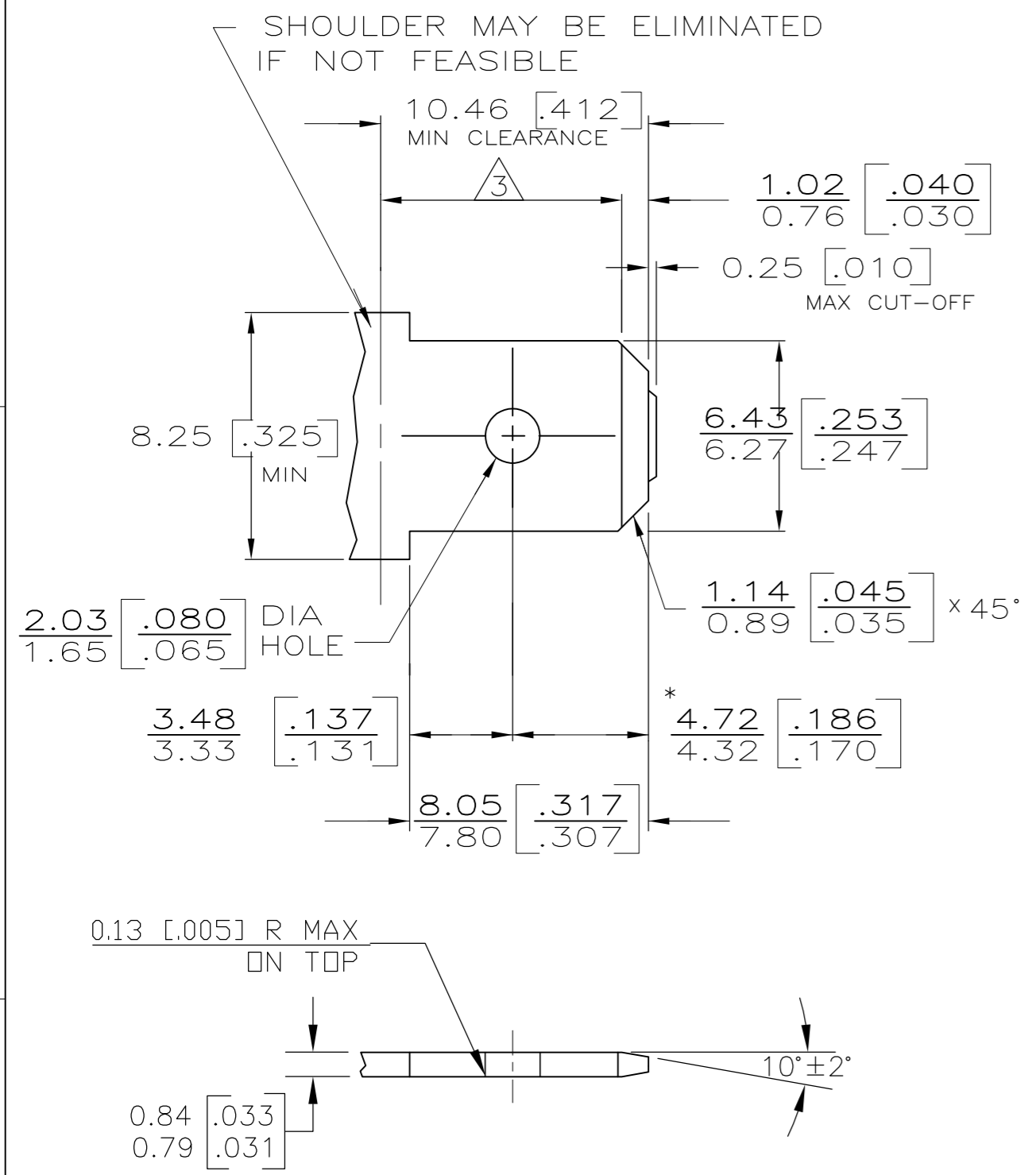

- 1 - MATL: 1/2H BRASS OR NICKEL PL STEEL.
  - 2 - NO BURRS PERMISSIBLE AT HOLE.
  - 3 - MUST BE FLAT WITHIN 0.076 [0.003] OVER THIS LENGTH.
  - 4 - TIN PLATING IS REQUIRED ON BRASS WHEN TERMINAL TEMP. IS OVER 225°F.
  - 5 - HOLE MUST BE SYMMETRICAL ABOUT TAB Q WITHIN 0.076 [0.003]
- \* TO BE USED ONLY WHEN SHOULDER IS ELIMINATED.

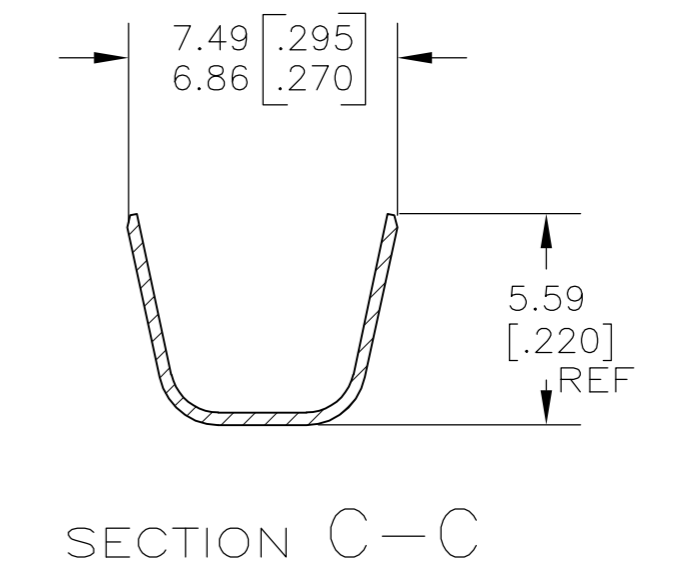
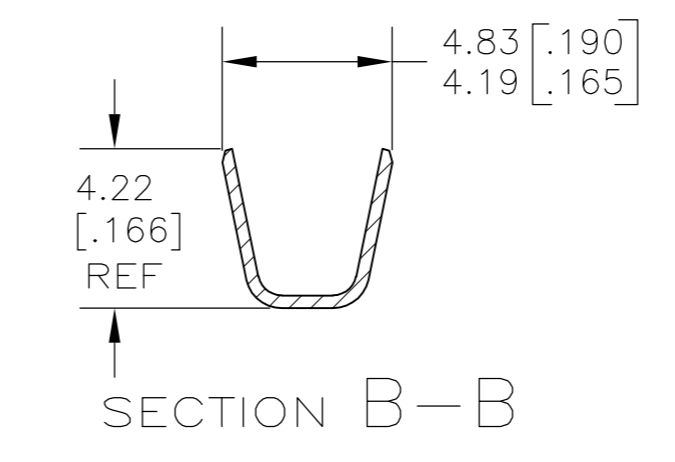
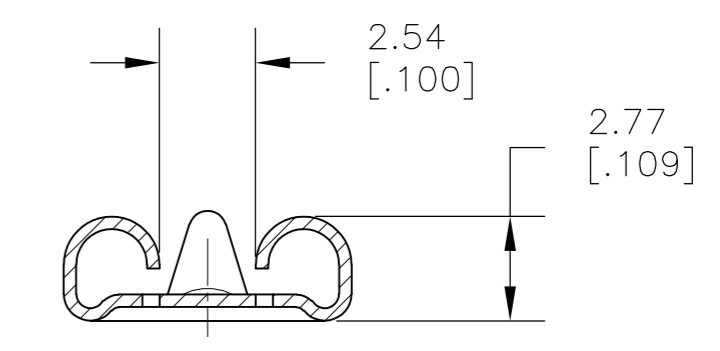
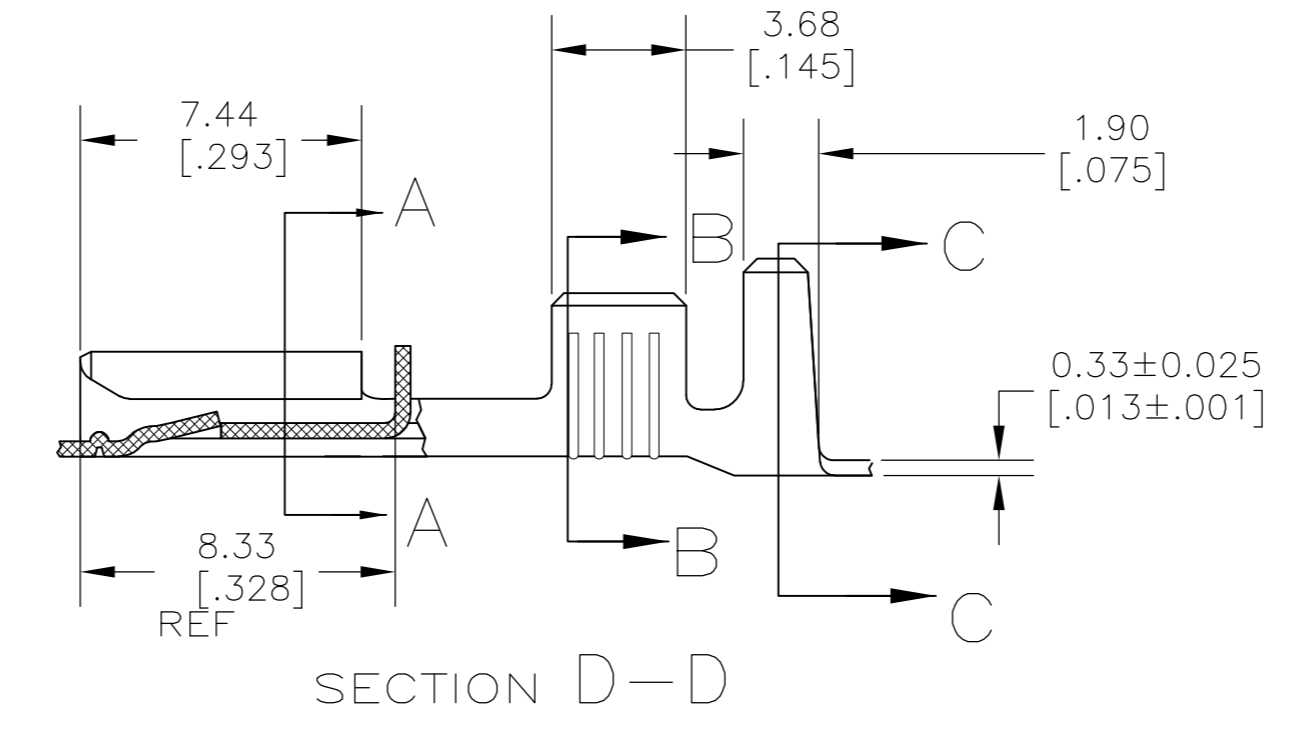
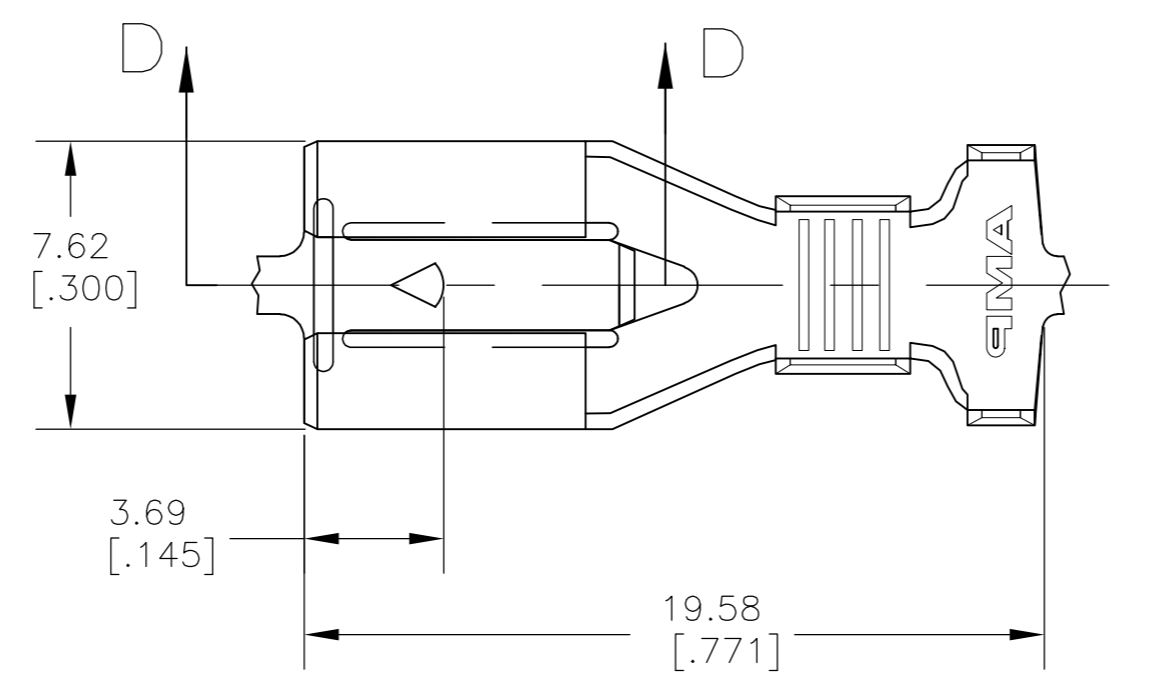

- 1 CONTINUOUS STRIP ON REELS.
  - 2 ACCEPTS [#16-#12] SINGLE WIRE SIZES AND COMBINATIONS OF TWO[#16'S] OR TWO[#18'S] OR ONE[#16 WITH ONE#18]. WIRE CRIMP WIDTH IS .140, F TYPE
  - 3 FITS INSULATION RANGE 3.05-4.32 [.120-.170] DIA OR TWO AT 3.05 [.120] MAX. INSULATION CRIMP WIDTH .240 F TYPE
- 4 PRELIMINARY - NOT FOR PRODUCTION

4	SILVER 0.00381 [.000150] MIN	1217095-3
	TIN 0.002032 [.000080] MIN	1217095-2
	-	1217095-1
	FINISH	PART NO

THIS DRAWING IS A CONTROLLED DOCUMENT.		DWN	JR RUTH	6/19/98		RECEPTACLE, POSITIVE LOCK, 6.35 [.250] SERIES		
DIMENSIONS: mm [ INCHES ]		CHK	MS FEHER	6/19/98		SIZE	CAGE CODE	DRAWING NO
TOLERANCES UNLESS OTHERWISE SPECIFIED:		APVD	J GILLESPIE	6/19/98		114-2074	A2 00779	C=1217095
0 PLC ± -		PRODUCT SPEC				RESTRICTED TO		
1 PLC ± -		APPLICATION SPEC			SCALE	SHEET	REV	
2 PLC ± 0.25 [.010]		MATERIAL	H06 BRASS	FINISH	SEE TABLE	5:1	1 of 1	
3 PLC ± -		CUSTOMER DRAWING					B2	
4 PLC ± -								
ANGLES ± -								