

VACCUUM COVER

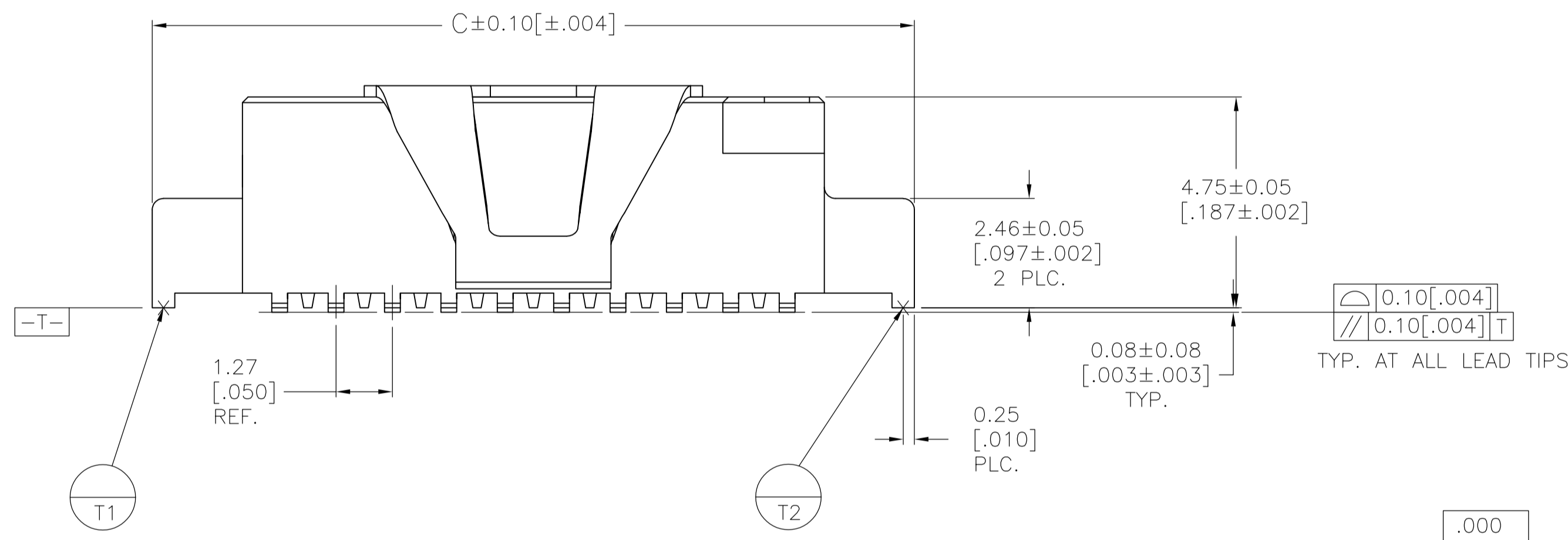

SECTION X-X

- 1 0.00076 [.000030] GOLD IN LOCALIZED GOLD PLATE AREA, 0.0038 [.000150] TIN-LEAD ON SOLDER LEADS, ALL OVER 0.00127 [.000050] NICKEL.
- 2 IF PLANNING TO USE MORE THAN ONE MATING PAIR OF CONNECTORS TO INTERCONNECT 2 BOARDS, PLEASE REFER TO THE SPACING PARAGRAPH IN APPLICATION SPEC.#114-7010.
- 3 VACCUUM COVER SHOWN IN PHANTOM.
- 4 PACKAGED IN TAPE AND REEL PER EIA-481 SPECIFICATIONS, SEE CHART FOR TAPE WIDTHS.
- 5 VACCUUM COVER DESIGNED FOR 4.0 [.160] DIA NOZZLE. VACCUUM COVER TO BE REMOVED AFTER SOLDERING.
- 6 HOUSING: LCP, COLOR BLACK. CONTACT: COPPER ALLOY PER ASTM SPECIFICATION B422. VACCUUM COVER: ALUMINUM ALLOY PER ASTM SPECIFICATION B209.
- 7 5.2 [.205] MIN. TARGET AREA FOR VACCUUM PICK-UP.
- 8 0.00076(.000030) GOLD IN LOCALIZED GOLD PLATE AREA, 0.0038(.000150) TIN ON SOLDER LEADS, ALL OVER 0.00127(.000050) NICKEL.
- 9 ROHS 2002/95/EC COMPLIANT.
- 10 OBSOLETE PARTS: OBSOLETE CIS STREAMLINING PER D.RENAUD/D.SINISI

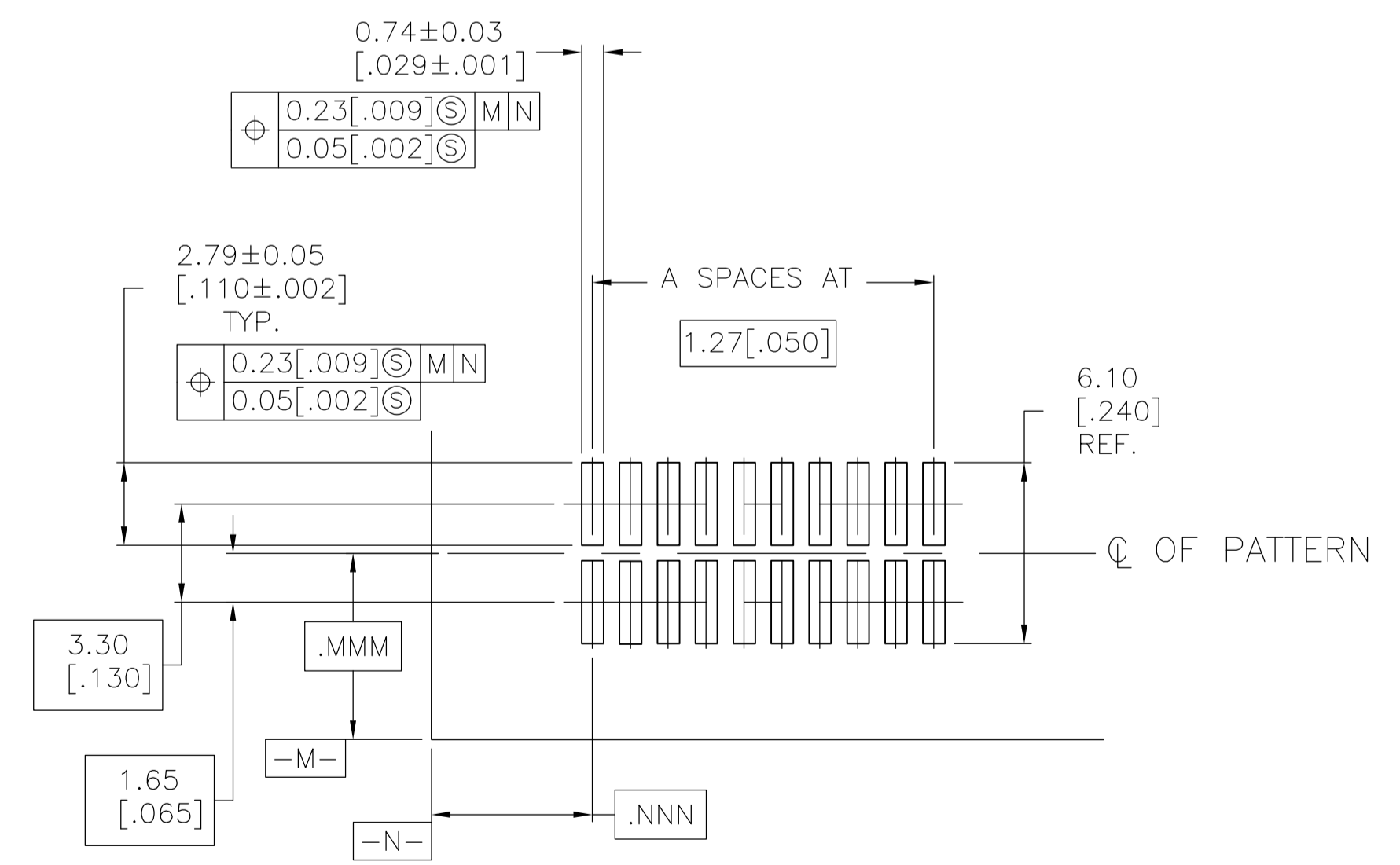

RECOMMENDED BOARD LAYOUT SCALE: 5:1

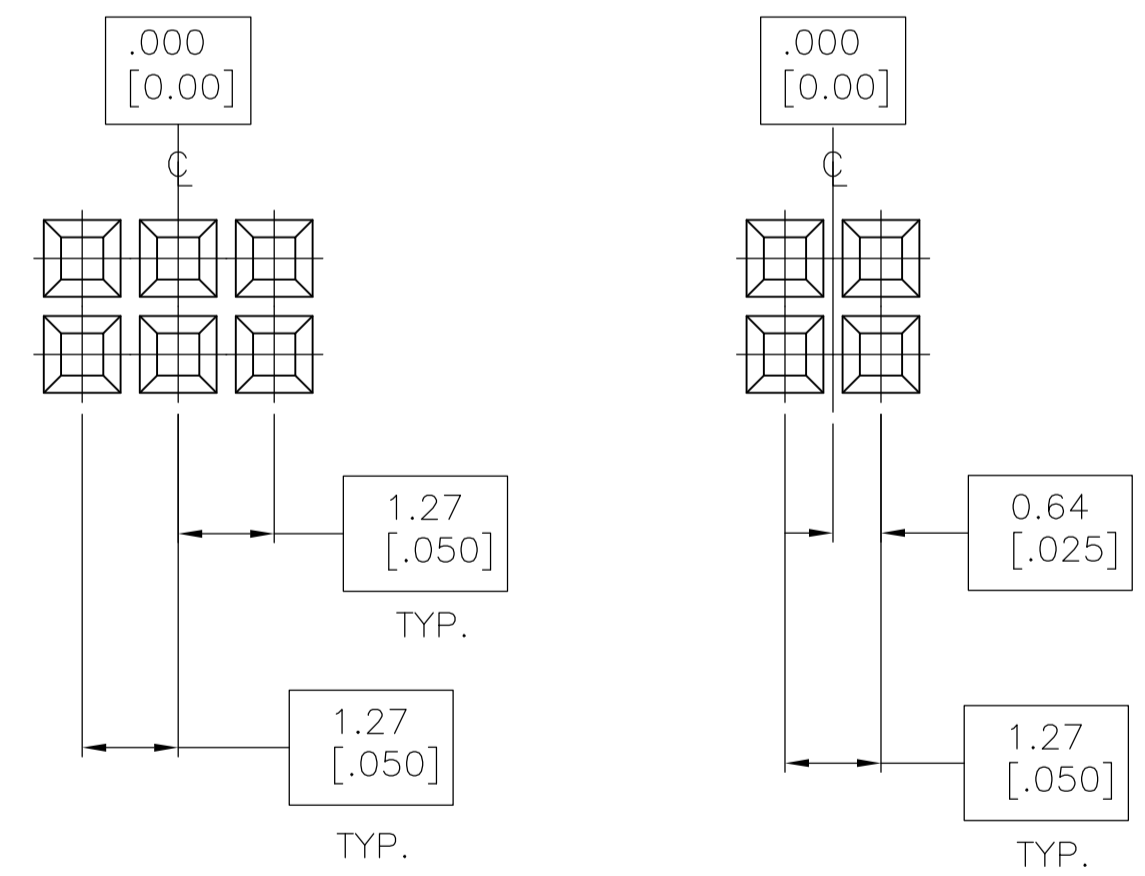

BASIC DIMENSIONS FOR EVEN NO. OF SPACES (SEE TABLE)
BASIC DIMENSIONS FOR ODD NO. OF SPACES (SEE TABLE)
DETAIL H

FINISH	TAPE WIDTH	D	C	B	A	NO. OF POS	PART NUMBER		
8/9	44mm	10.41 [.410]	23.52 [.926]	19.46 [.766]	14	30	5-147413-4		
8/9	32mm	7.24 [.285]	17.17 [.676]	13.11 [.516]	9	20	5-147413-3		
10	OBSOLETE	8/9	56mm	16.76 [.660]	36.22 [1.426]	32.16 [1.266]	24	50	5-147413-2
8/9	32mm	4.06 [.160]	10.82 [.426]	6.75 [.266]	4	10	5-147413-1		
1	44mm	10.41 [.410]	23.52 [.926]	19.46 [.766]	14	30	147413-4		
1	32mm	7.24 [.285]	17.17 [.676]	13.11 [.516]	9	20	147413-3		
OBSOLETE	1	56mm	16.76 [.660]	36.22 [1.426]	32.16 [1.266]	24	50	147413-2	
1	32mm	4.06 [.160]	10.82 [.426]	6.75 [.266]	4	10	147413-1		

THIS DRAWING IS A CONTROLLED DOCUMENT. DIM T. SMITH 30MAR00. CHK D. SIMPSON 30MAR99. NAME ASSEMBLY, RECEPTACLE, VERTICAL, DOUBLE ROW, SURFACE MOUNT 50/50 GRID CONNECTOR. PRODUCT SPEC 108-1332. APPLICATION SPEC 114-7010. SIZE A1. WEIGHT -. CUSTOMER DRAWING. SCALE 10:1. SHEET 1 OF 1. REV E5.