

- 1 POST TO WITHSTAND 13 NEWTONS [3 LBS.] MIN. AXIAL FORCE IN BOTH DIRECTIONS SHOWN WITHOUT DISLODGING.
- 2 TOLERANCES APPLY TO SOLDER SIDE OF BOARD.
- 3 MEASURED AT SURFACE $\overline{-A-}$
- 4 PLASTIC FLASH PERMITTED IN THIS AREA.
- 5 PARTS COMPLY WITH SOLDERABILITY SPEC. 109-11-2
- 6 ONE HOLE MAY BE UNDERSIZED 0.81-0.89 [0.032-0.035] DIA. FOR ASSEMBLY RETENTION DURING WAVE SOLDERING.
- 7 MATERIAL: HEADER-THERMOPLASTIC POLYESTER
94V-0(NATURAL)
POST-COPPER ALLOY (TIN PLATED)
- 8 COORDINATE DIMENSION APPLIES FROM CENTER OF ACTUAL FEATURE.
- 9 PLASTIC BURRS CAUSED BY CUT-OFF TOOLING ARE PERMITTED WITHIN THE MAXIMUM TOLERANCE ENVELOPE.
- 10 POSTS TO BE MEASURED WHEN STRIP IS HELD FLAT.
- 11 POSTS MUST WITHSTAND TWO 90° BENDS AGAINST EXTRUSION WITHOUT BREAKING.
- 12 DIMENSION SHOULD BE 2.79-4.06 [0.110-.160] WHEN MATING WITH A MTA 100 CONNECTOR ASSEMBLY OR 2.79-3.05 [0.110-.120] WHEN MATING WITH A CST 100 CONNECTOR.
- 13 PIN BURR OF 0.13 [0.005] MAX. VERTICAL AND 0.08 [0.003] MAX. HORIZONTAL PERMITTED AT POST TIPS ON BOTH ENDS.

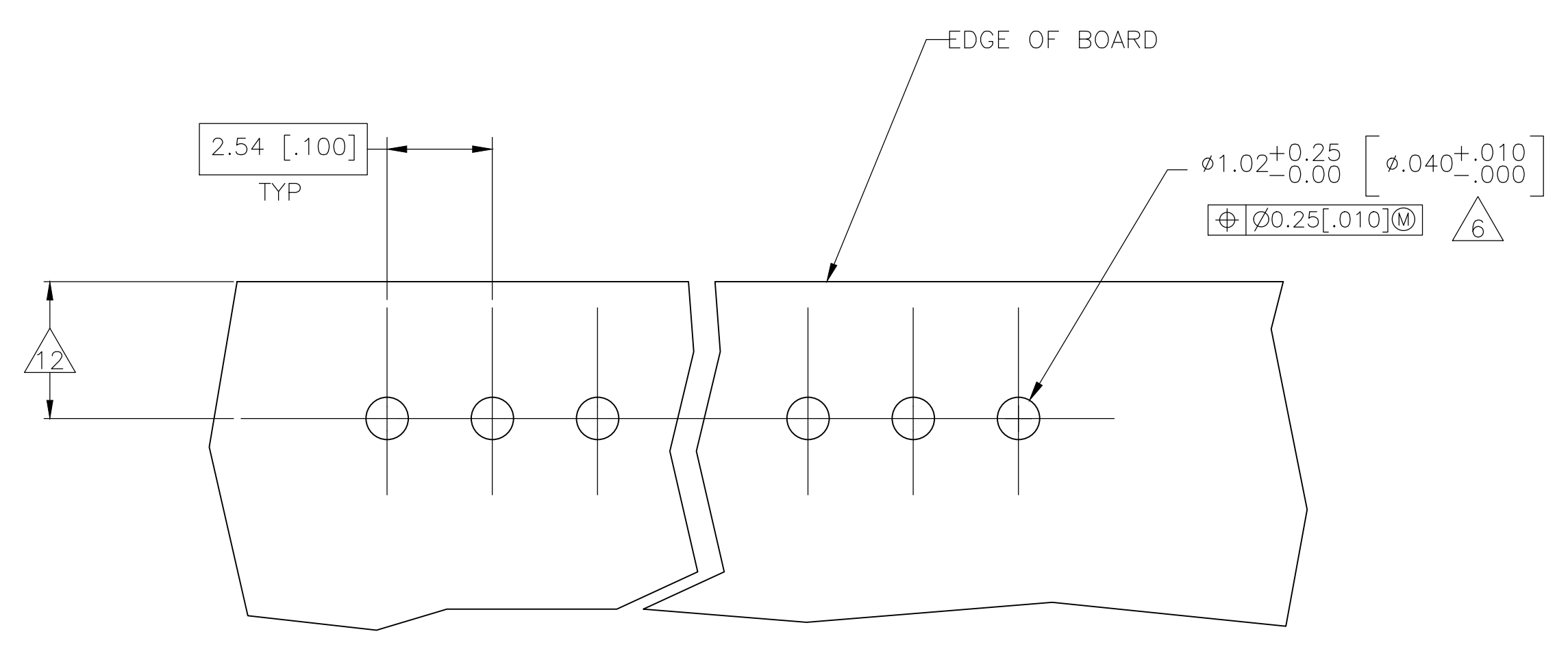
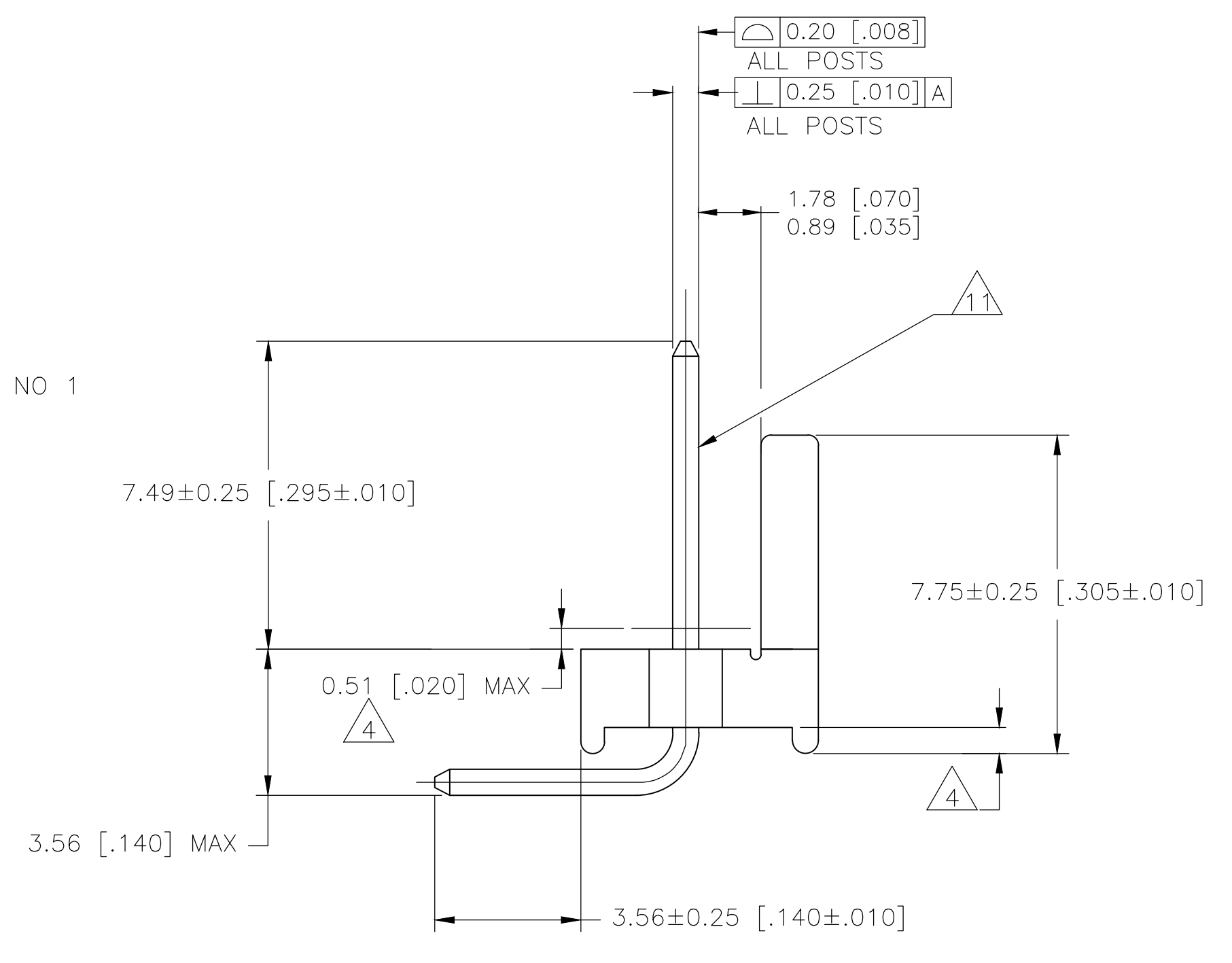
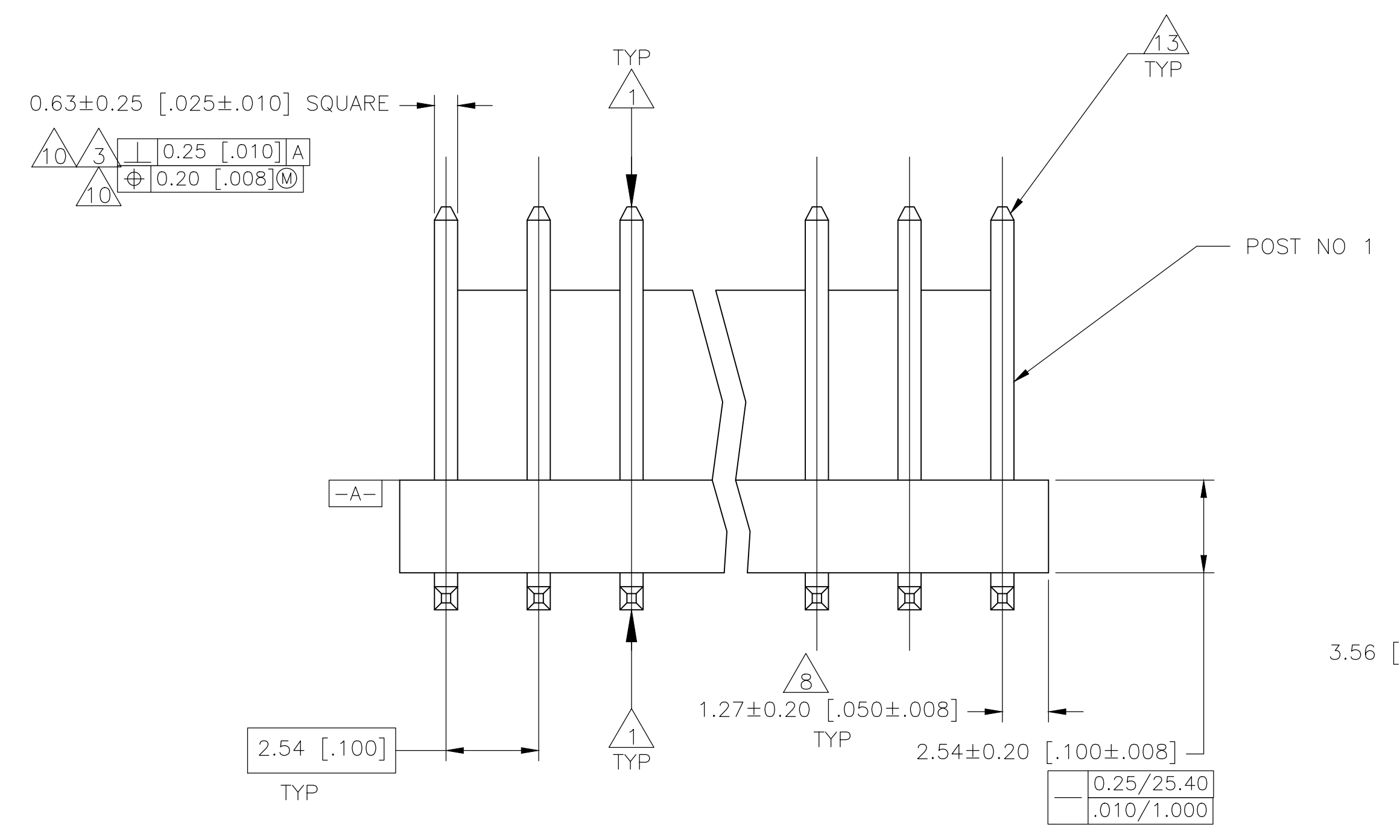

RECOMMENDED MOUNTING HOLE PATTERN FOR 1.60 [0.063] THICK P.C. BOARD $\triangle 2$

MM	[IN]	NO OF POSITIONS	PART NUMBER
71.12	2.800	28	2-640455-8
68.58	2.700	27	2-640455-7
66.04	2.600	26	2-640455-6
63.50	2.500	25	2-640455-5
60.96	2.400	24	2-640455-4
58.42	2.300	23	2-640455-3
55.88	2.200	22	2-640455-2
53.34	2.100	21	2-640455-1
50.80	2.000	20	2-640455-0
48.26	1.900	19	1-640455-9
45.72	1.800	18	1-640455-8
43.18	1.700	17	1-640455-7
40.64	1.600	16	1-640455-6
38.10	1.500	15	1-640455-5
35.56	1.400	14	1-640455-4
33.02	1.300	13	1-640455-3
30.48	1.200	12	1-640455-2
27.94	1.100	11	1-640455-1
25.40	1.000	10	1-640455-0
22.86	.900	9	640455-9
20.32	.800	8	640455-8
17.78	.700	7	640455-7
15.24	.600	6	640455-6
12.70	.500	5	640455-5
10.16	.400	4	640455-4
7.62	.300	3	640455-3
5.08	.200	2	640455-2

THIS DRAWING IS A CONTROLLED DOCUMENT.

DIMENSIONS: mm [INCHES]	TOLERANCES UNLESS OTHERWISE SPECIFIED:	DIN S. HAMM 22-OCT-2001	APVD D. ROSSI 22-OCT-2001	NAME
0 PLC ± -	1 PLC ± -	2 PLC ± -	3 PLC ± 0.13 [0.005]	APPLICATION SPEC
4 PLC ANGLES ± 0°30'	FINISH	WEIGHT	SIZE	CAGE CODE
MATERIAL $\triangle 7$	FINISH $\triangle 7$	WEIGHT	SIZE A1	CAGE CODE 00779

STE TE Connectivity

MTA-100 HEADER ASSEMBLY, POLARIZED, NOTCHED, .025 SQUARE RIGHT ANGLE POST, TIN PLATED

CUSTOMER DRAWING SCALE 8:1 SHEET 1 OF 1 REV Y2

