

### CONNECTOR ASSEMBLY EXAMPLARY LOADED

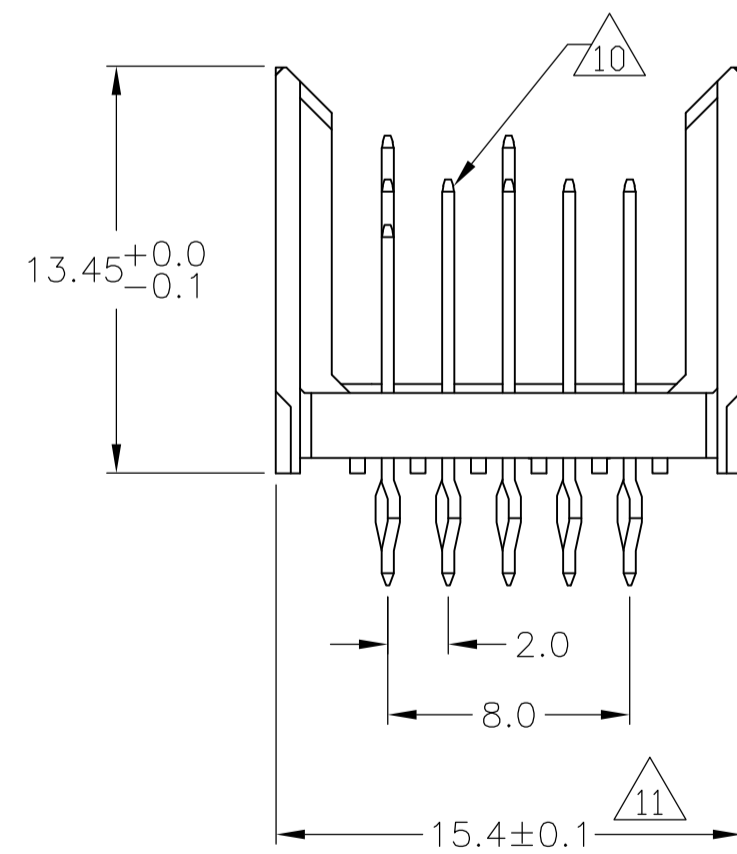

### CONTACT DIMENSIONS

SCALE 5:1

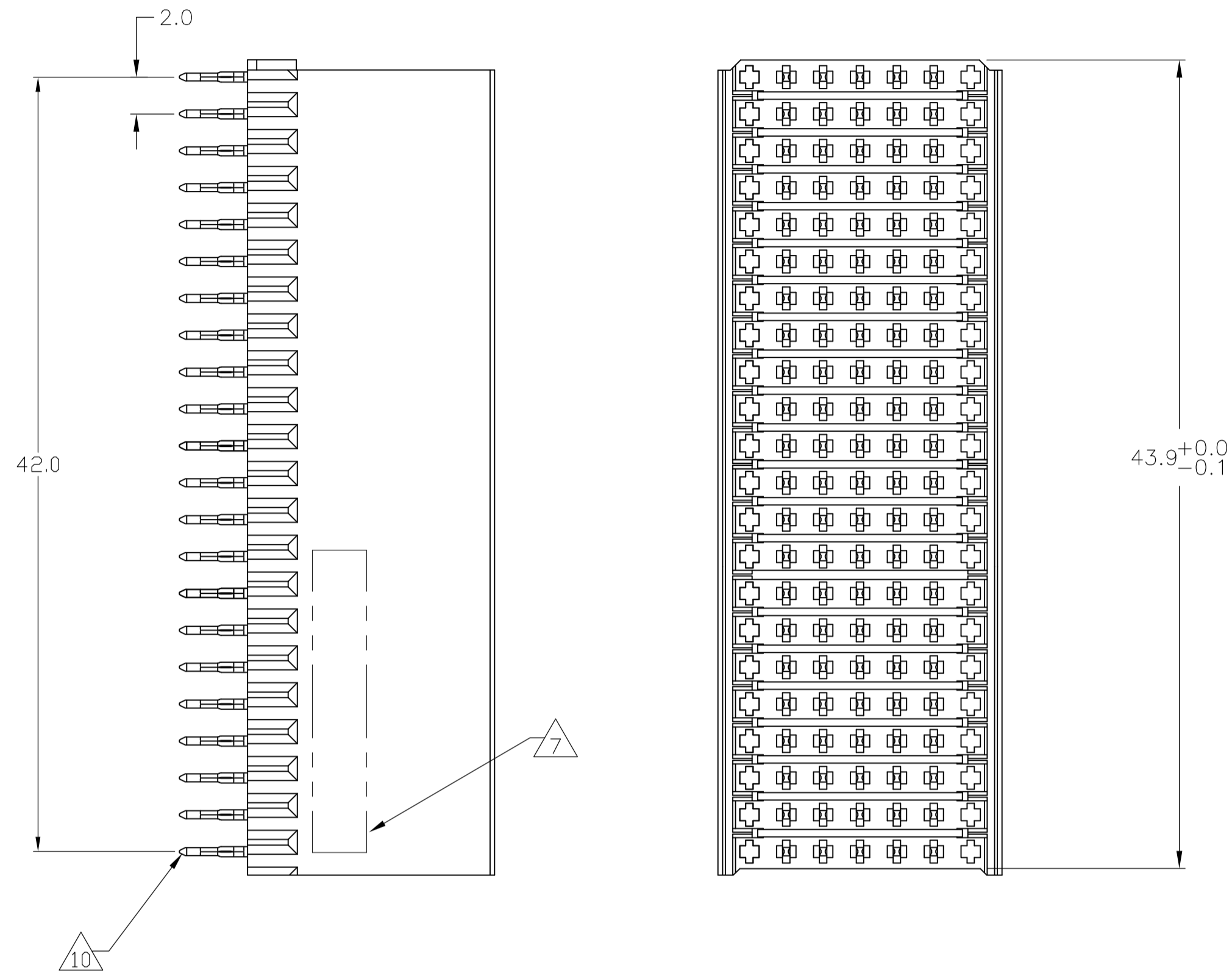
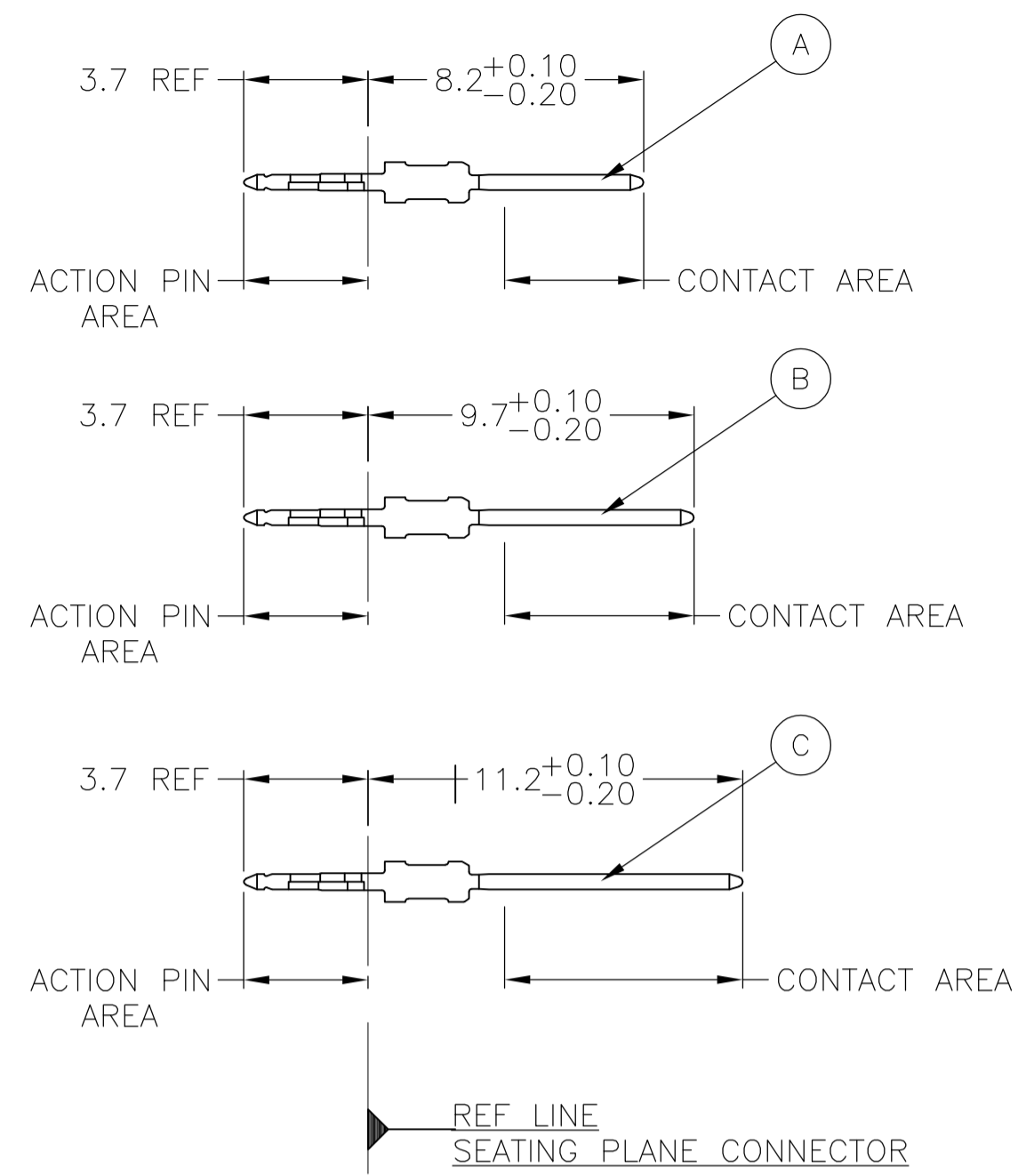

### CONTACT LAYOUT

	z	a	b	c	d	e	f
1		B	B	B	B	B	
2		B	B	B	B	B	
3		B	B	B	B	B	
4		B	B	B	B	B	
5		B	B	B	B	B	
6		B	B	B	B	B	
7		B	B	B	B	B	
8		B	B	B	B	B	
9		B	B	B	B	B	
10		B	B	B	B	B	
11		C	B	C	B	B	
12		B	B	B	B	B	
13		B	B	B	B	B	
14		B	B	B	B	B	
15		B	B	B	B	B	
16		B	B	B	B	B	
17		B	B	B	B	B	
18		B	B	B	B	B	
19		B	B	B	B	B	
20		B	B	B	B	B	
21		B	B	B	B	B	
22		A	B	B	B	B	

### RECOMMENDED PCB-HOLE LAYOUT COMPONENT SIDE SHOWN

### PLATED THRU HOLES PARAMETERS

REFERENCE APPLICATION SPECIFICATION

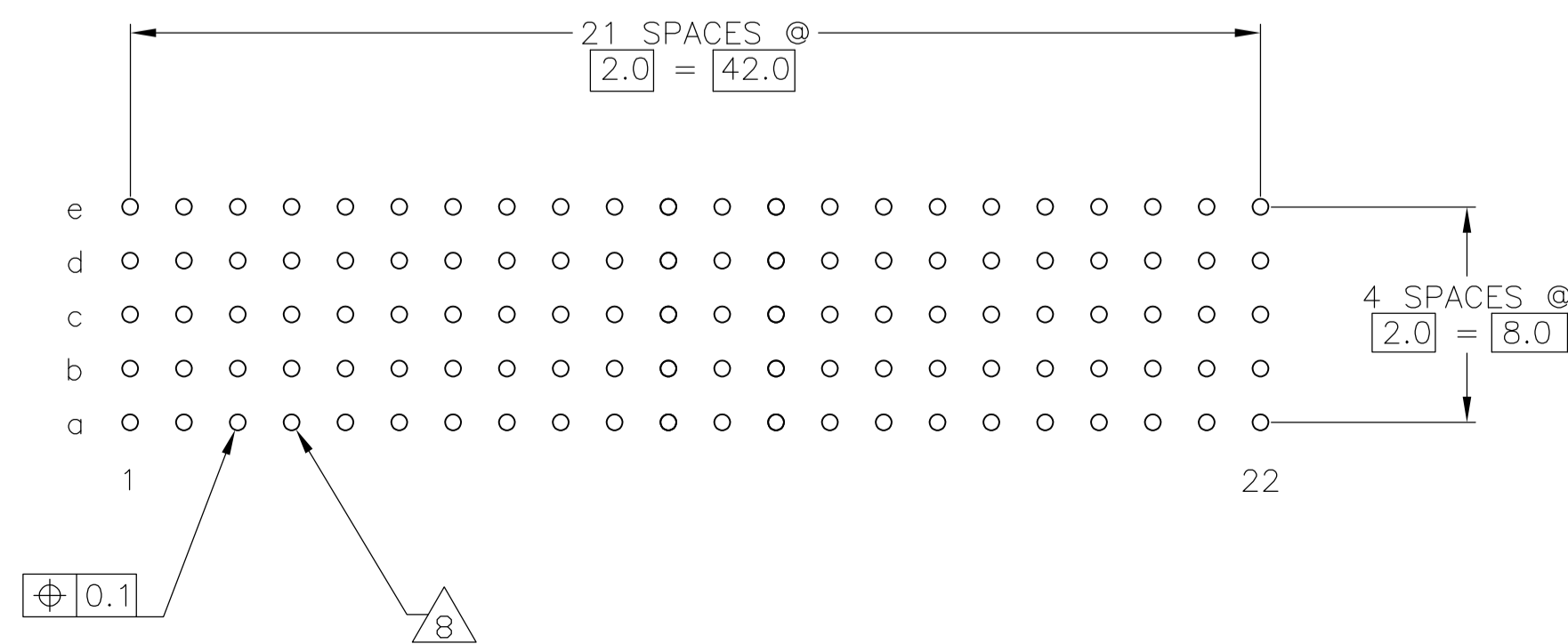

2 6 12	1-1645457-9
2 5 12	1645457-9
2 4	1645457-4
2 3	1645457-1
FINISH	PART NUMBER

THIS DRAWING IS A CONTROLLED DOCUMENT.		DIN D. HUMBERT 27MARCH2008	Tyco Electronics Corporation Harrisburg, Pa 17105-3608	
DIMENSIONS: mm		CIK J. FABY 27MARCH2008	Tyco Electronics	
TOLERANCES UNLESS OTHERWISE SPECIFIED:		APVD J. FABY 27MARCH2008	NAME	
0-PLC ±	±0.2	108-19082		
1-PLC ±0.1		APPLICATION SPEC		
2-PLC ±		114-19029		
3-PLC ±		SIZE CASE CODE DRAWING NO		
4-PLC ±		A1 00779 C=1645457		
ANGLES ±		RESTRICTED TO		
MATERIAL 1	SEE TABLE	CUSTOMER DRAWING		
		SCALE 4:1		SHEET 1 OF 2

LOC		DIST		REVISIONS				
P	LTR	DESCRIPTION	DATE	DN	APVD			
AD	00	SEE SHEET 1	-	-	-			

- 1 MATERIAL:  
CONTACT: PHOSPHOR BRONZE.  
HOUSING: GLASS-FILLED POLYESTER.
- 2 GENERAL PLATING SPECIFICATION: UNDERPLATING  
(ENTIRE CONTACT): 1.27µm MIN NICKEL AND ACTION  
PIN: 0.5µm MIN TIN/LEAD.  
FOR PLATING OF MATING SURFACES SEE APPLICABLE  
SPECIFICATION REFERENCE FOR EACH DASH NUMBER.
- 3 CONFORMS TO ALL TESTING ACCORDING TO IEC 61076-4-101  
PERFORMANCE LEVEL 2.
- 4 CONFORMS TO ALL TESTING ACCORDING TO IEC 61076-4-101  
PERFORMANCE LEVEL 1.
- 5 CONNECTOR TESTED AND QUALIFIED AGAINST TELCORDIA GR-1217-CORE QUALITY LEVEL 3,  
CENTRAL OFFICE APPLICATIONS.
- 6 CONNECTOR TESTED AND QUALIFIED AGAINST TELCORDIA GR-1217-CORE QUALITY LEVEL 3,  
UNCONTROLLED ENVIROMENT APPLICATIONS.
- 7 CONNECTOR MARKED WITH PART NUMBER AND DATE CODE.  
ADDITIONAL CHARACTERS OR MARKINGS, AS WELL AS THE LOCATION OF THE MARKINGS,  
MAY BE ADDED FOR TRACEABILITY BASED UPON MANUFACTURERS DISCRETION.
- 8 PLATED-THROUGH HOLES AT 2x2mm SQUARE GRID  
PATTERN DEFINED BY CONTACT LAYOUT.
- 9 FOR ACTUAL PIN LOADING SEE "CONTACT LAYOUT".
- 10 FOR ACTUAL PIN DIMENSIONS SEE "CONTACT DIMENSIONS".
- 11 TO BE MEASURED AT BOTTOM OF SHROUD.
- 12 CONNECTOR LUBRICATED WITH BELCORE APPROVED LUBRICANT,  
TECHNICAL REFERENCE: TR-NWT-001217 ISSUE 1, SEP 1992.

THIS DRAWING IS A CONTROLLED DOCUMENT.		DIN D. HUMBERT 27MARCH2008		Tyco Electronics Corporation Harrisburg, Pa 17105-3608	
DIMENSIONS: mm		TOLERANCES UNLESS OTHERWISE SPECIFIED: 0-PLC ± 1-PLC ± 0.1 2-PLC ± 3-PLC ± 4-PLC ± ANGLES ±		APVD J. FABY 27MARCH2008	
		±0.2		NAME 108-19082 PRODUCT SPEC	
MATERIAL SEE SHEET 1		FINISH SEE SHEET 1		APPLICATION SPEC 114-19029	
		WEIGHT -		SIZE A1	
		CUSTOMER DRAWING		SCALE 4:1 SHEET 2 OF 2 REV B	