

Layout Form

HV8P DRAWER

PIN ASSEMBLY

1. Enter the quantity of each pin contact you require in the **Qty** column of the **Pin Contact Selection Menu** table.
2. **For the contacts you want Elcon to install**, enter the reference letter of the desired pin contact in the appropriate contact position on the drawing; e.g., if you need a size #12 premate PCB tail contact to be installed in contact position #8, write "H" in circle #8.
3. Sign, date and fax the completed form to Elcon at the appropriate fax number for your location (see the bottom of the page).

ENTER CUSTOMER INFORMATION	
Company	Location
Contact Name	Title
Telephone	Fax
Email Address	
I am: <input type="checkbox"/> End user <input type="checkbox"/> Contract manufacturer (end user: _____)	
Signature	Today's Date
	Estimated production volume

Add me to Elcon mailing list.

Pin housing (rear face)
Pin contact insertion side. Pin connector rear face cavity identification

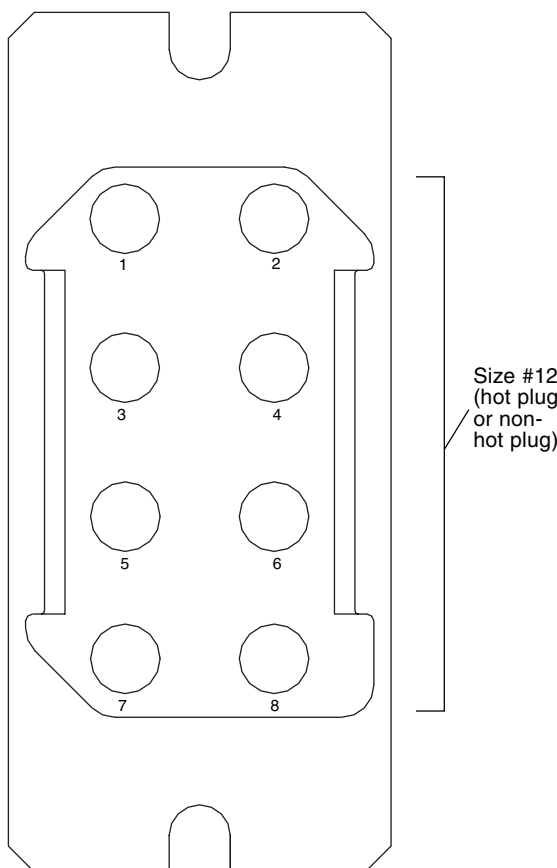

Pin Housing Part Number
235-0152-01100

Pin Contact Selection Menu				
Size	Ref	Part Number	Termination, Pin Length	Qty
#12	A	= 701-12-02107	Crimp, standard	
	B	= 701-15-02107	Crimp, premate	
	C	= 701-16-02107	Crimp, postmate	
	D	= 707-14-02107	Solder cup, standard	
	E	= 707-44-02107	Solder cup, premate	
	F	= 707-45-02107	Solder cup, postmate	
	G	= 707-16-02107	PCB tail, standard	
	H	= 707-47-02107	PCB tail, premate	
	I	= 707-46-02107	PCB tail, postmate	
#12 Hot Plug	J	= 701-12-02109	Crimp, standard, hot plug	
	K	= 701-15-02109	Crimp, premate, hot plug	
	L	= 707-14-02109	Solder cup, standard, hot plug	
	M	= 707-44-02109	Solder cup, premate, hot plug	
	N	= 707-16-02109	PCB tail, standard, hot plug	
	P	= 707-47-02109	PCB tail, premate, hot plug	

403-

Top assembly P/N assigned by Elcon
Use this P/N to place your order.

Layout Form

HV8P DRAWER

SOCKET ASSEMBLY

1. Enter the quantity of each socket contact you require in the **Qty** column of the **Socket Contact Selection Menu** table.
2. **For the contacts you want Elcon to install**, enter the letter reference of the desired socket contact in the appropriate contact position on the drawing; e.g., if you need a size #12 PCB tail contact to be installed in contact position #8, write "C" in circle #8.
3. Sign, date and fax the completed form to Elcon at the appropriate fax number for your location (see the bottom of the page).

ENTER CUSTOMER INFORMATION	
Company	Location
Contact Name	Title
Telephone	Fax
Email Address	
I am: <input type="checkbox"/> End user <input type="checkbox"/> Contract manufacturer (end user: _____)	
Signature	Today's Date
	Estimated production volume

Add me to Elcon mailing list.

Socket housing (rear face)

Socket contact insertion side. Socket connector rear face cavity identification

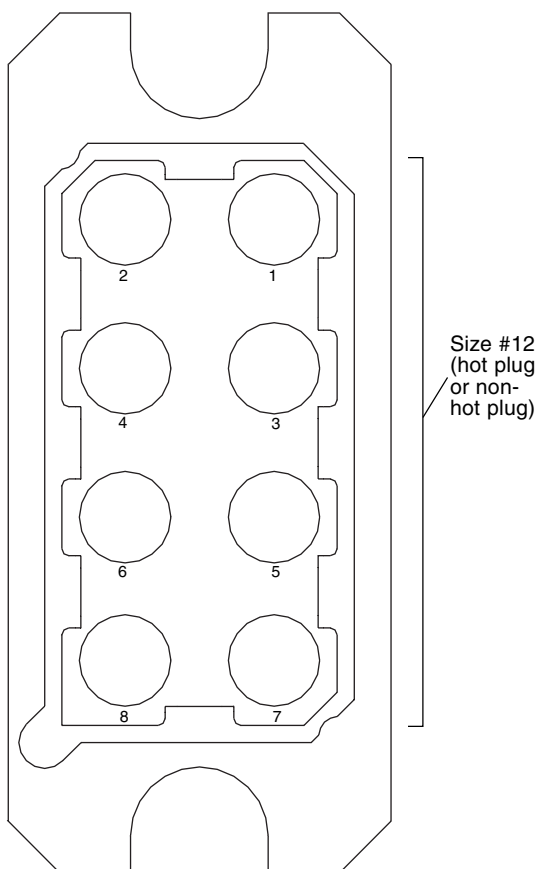

Socket Housing Part Number
235-0153-01100

Socket Contact Selection Menu				
Size	Ref	Part Number	Termination	Qty
#12	A =	702-32-01107	Crimp	
	B =	708-21-01107	Solder cup	
	C =	708-23-01107	PCB tail	
#12 Hot Plug	D =	708-73-01109	Crimp, hot plug	
	E =	708-76-01109	Solder cup, hot plug	
	F =	708-77-01109	PCB tail, hot plug	

Float Mount Shoulder Screw		
Part Number	Description	Qty
902-83-02113	Screw No. 8-32 UNC 2A	
903-19-02113	Screw M4 x 0.7	

404-

Top assembly P/N assigned by Elcon
Use this P/N to place your order.