

REVISIONS					
#	DATE	DESCRIPTION	BY	CHK	APPD
E	23APR2013	LOGO CHANGE	JC	KZ	

MECHANICAL:

MATERIALS:
 HOUSING - THERMOPLASTIC PET POLYESTER FLAMMABILITY RATING UL 94V-0.
 SHIELD - .010" THICK, C26800 BRASS PREPLATED WITH 30μinch MIN SEMI-BRIGHT NICKEL; SOLDER TABS POST DIPPED WITH 100μinch MIN SAC SOLDER.
 MOD JACK CONTACTS - .0157" x .018", PHOSPHOR BRONZE, 50μinch MIN OVERALL NICKEL UNDERPLATE, WITH SELECT 50μinch MIN HARD GOLD FINISH PLATE. SOLDER TAILS WITH 100μinch MIN MATTE TIN AND/OR SAC SOLDER DIP.
 LIGHT EMITTING DIODE(LED) - DIFFUSED EPOXY LENS, .020" x .020" CARBON STEEL WIREFRAME LEADS PREPLATED WITH 80μinch SILVER OVER 40μinch NICKEL UNDERPLATE OVER 40μinch COPPER UNDERPLATE; POST-PLATED WITH 100μinch MIN MATTE TIN AND/OR SAC SOLDER DIP OR PURE TIN SOLDER DIP.

RJ45 JACK CAVITY CONFORMS TO FCC RULES AND REGULATIONS PART 68, SUB PART F.

MAGNETICS:
 -IMPEDANCE: 100 OHMS
 -TRANSMIT OPEN CIRCUIT INDUCTANCE (OCL): 350μH (MIN) @100KHZ, 0.1VRMS WITH 8 mA DC BIAS. FOR EACH TRANSFORMER OVER T = 0°C TO +70°C.

-TURNS RATIO (CHIP: CABLE): TX: 1:1, RX: 1:1

PERFORMANCE: @ 25°C

-INSERTION LOSS (IL): 1.1db MAX FROM 0.5MHz TO 100MHz

-RETURN LOSS (RL): 18db MIN FROM 0.5MHz TO 30MHz
 18 - 20LOG (f/30)db MIN FROM 30.1MHz TO 60MHz
 12db MIN FROM 60.1MHz TO 80MHz

-CROSSTALK ATTENUATION: 35db MIN FROM 0.5MHz TO 40MHz
 33-20LOG (f/50)db MIN FROM 40.1MHz TO 100MHz

-COMMON MODE REJECTION RATIO (CMRR): 30db MIN FROM 0.5MHz TO 100MHz

-DIELECTRIC (ISOLATION VOLTAGE): 2250 VDC (1mA CUTOFF CURRENT), 60 SECONDS BETWEEN ALL RJ45 CONTACTS AND ALL SIGNAL PINS WITH OUTER SHIELD

4. OPERATING TEMPERATURE: FROM 0°C TO +70°C.

THE 250 OHM LED RESISTORS ARE OPTIONAL, PLEASE SEE CHART FOR PRESENCE OR ABSENCE OF LED RESISTORS. IF THE LED WITHOUT 250 OHM RESISTORS, LED IS DRIVEN WITH CONSTANT CURRENT AT APPROX 20mA.

LED COLOR: DOMINANT WAVELENGTH (AD): GREEN 568 nm TYP. at IF=20mA
 FORWARD VOLTAGE (VF): GREEN 2.2V TYP. at IF=20mA
 DOMINANT WAVELENGTH (AD): YELLOW 588 nm TYP. at IF=20mA
 FORWARD VOLTAGE (VF): YELLOW 2.1V TYP. at IF=20mA.

IF THE LED WITH 250 OHM RESISTORS,LED IS DRIVEN WITH 5V VOLTAGE AND THE MAX OPERATING CURRENT IS 20mA.

LED COLOR : DOMINANT WAVELENGTH (AD): GREEN 568 nm TYP. At VF=5V
 FORWARD CURRENT (IF): GREEN 12 mA TYP. at VF=5V
 DOMINANT WAVELENGTH (AD): YELLOW 588 nm TYP. At VF=5V
 FORWARD CURRENT (IF): YELLOW 13 mA TYP. at VF=5V

INDICATED CONNECTIONS ARE FOR NIC CONFIGURATION. THE MAGNETICS ARE ASYMMETRICAL, AND DO NOT SUPPORT AUTO-MDI/MDIX.

TRP CONNECTOR LOGO,TE CONNECTIVITY PART NUMBER, DATE CODE, COUNTRY OF ORIGIN AND AGENCY APPROVAL MARKING IN APPROXIMATE LOCATION SHOWN.

8. THESE PARTS ARE RECOMMENDED FOR WAVE SOLDERING PROCESS,PEAK WAVE SOLDERING TEMPERATURE IS 265°C MAX,10 SECONDS MAX.

	YES	GREEN	YES	GREEN	YES	6-6605706-1
OBsolete	YES	YELLOW	NO	GREEN	NO	5-6605706-9
OBsolete	YES	GREEN	NO	YELLOW	NO	5-6605706-8
OBsolete	YES	GREEN	NO	GREEN	NO	5-6605706-7
	YES	GREEN/YELLOW	NO	GREEN/YELLOW	NO	5-6605706-6
	YES	GREEN/YELLOW	NO	GREEN	NO	5-6605706-5
	YES	YELLOW	YES	GREEN	YES	5-6605706-2
	YES	GREEN	YES	YELLOW	YES	5-6605706-1
	NO	GREEN	YES	GREEN	YES	1-6605706-1
OBsolete	NO	GREEN	NO	GREEN	NO	6605706-7
	NO	GREEN/YELLOW	NO	GREEN/YELLOW	NO	6605706-6
	NO	GREEN	YES	YELLOW	YES	6605706-1
		2KV DECOUPLING CAPACITOR	LED1	250 OHMS RESISTOR	LED2	250 OHMS RESISTOR
						PART NUMBER

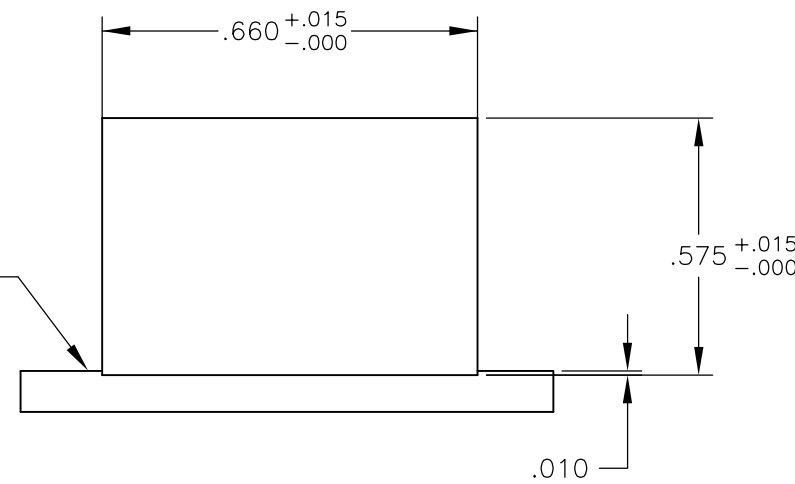
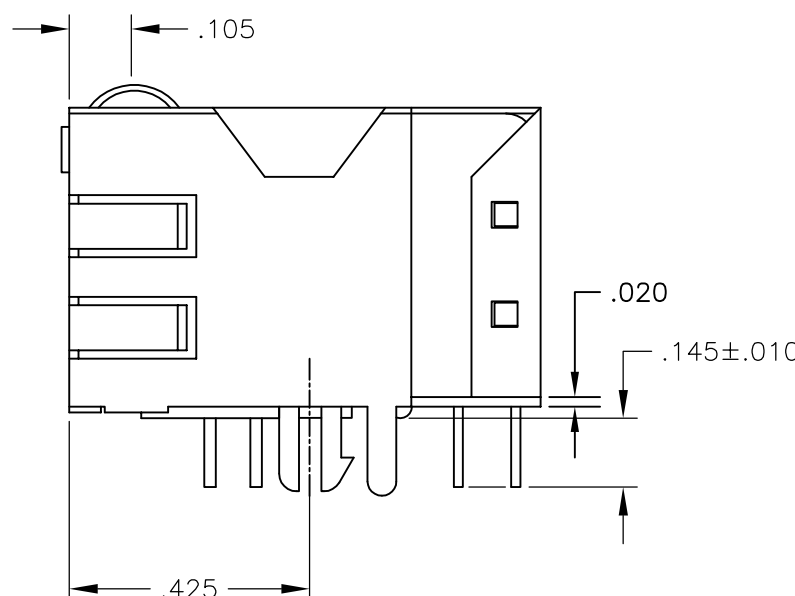
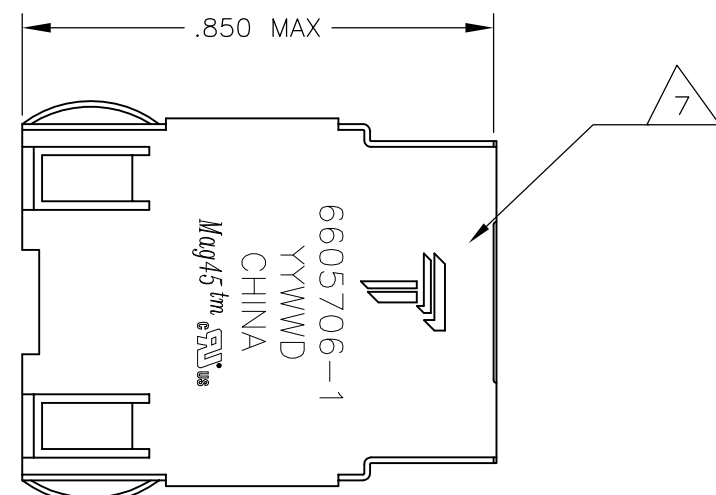

Suggested Panel Cutout

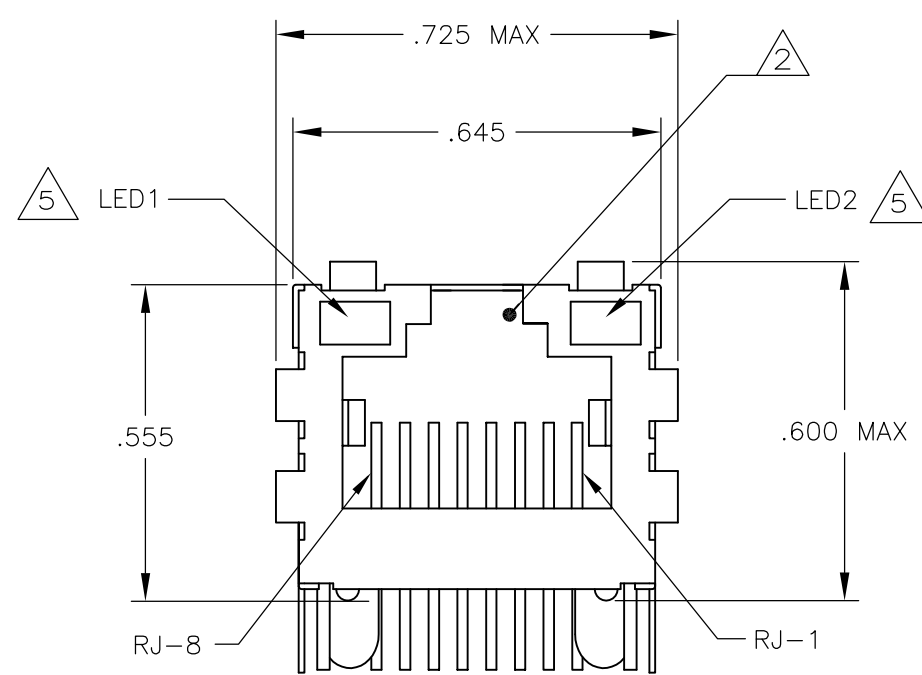

THIS DRAWING IS A CONTROLLED DOCUMENT.

DIMENSIONS: INCHES 0 PLC ± - 1 PLC ± .01 2 PLC ± .005 3 PLC ± .005 4 PLC ± .005 ANGLES ± -	TOLERANCES UNLESS OTHERWISE SPECIFIED: 0 PLC ± - 1 PLC ± .01 2 PLC ± .005 3 PLC ± .005 4 PLC ± .005 ANGLES ± -	TRP connector Dongguan China PRODUCT SPEC 108-2100 APPLICATION SPEC NAME 1X1 MAG45 (TM) MODULAR JACK, 7N2 SCHEMATIC, 714 SERIES CIRCUIT, SHIELDED, OPTIONAL DECOUPLING CAPACITOR WITH LEDS SIZE A1 CASE CODE C=6605706 DRAWING NO RESTRICTED TO
---	--	---

CUSTOMER DRAWING SCALE 1:1 SHEET 1 OF 2 REV E

REVISIONS				
#	LR	DESCRIPTION	DATE	APPD
-	-	-	-	-

714 SERIES MAGNETIC CIRCUIT 

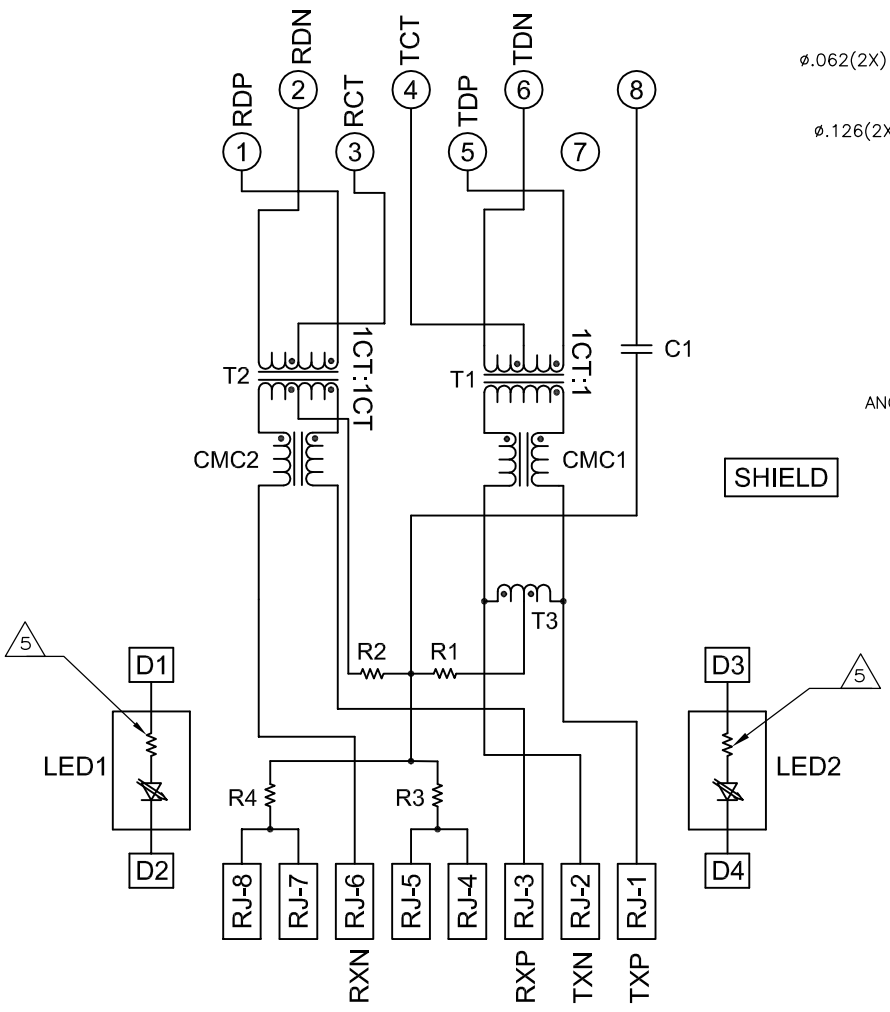

C1 = 1000pF, 2kV DECOUPLING CAPACITOR
 R1-R4 = 75 OHMS, 1/16W, RESISTORS

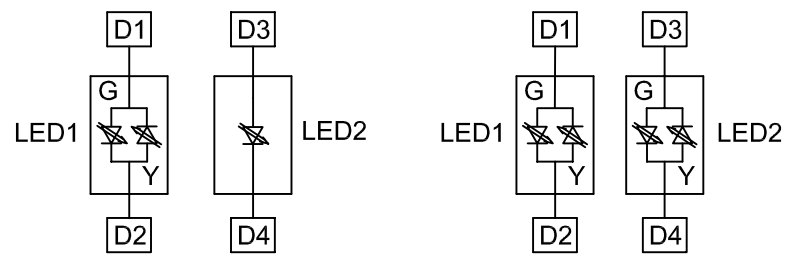

LED CONFIGURATION FOR 5-6605706-5 ONLY
 LED CONFIGURATION FOR 6605706-6 AND 5-6605706-6

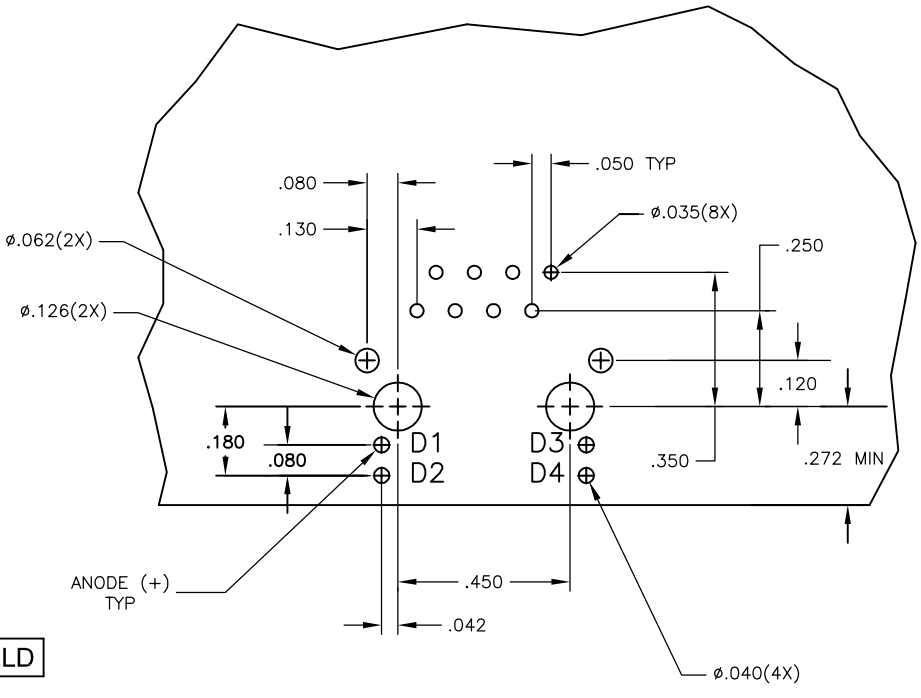

Suggested PCB Layout
 (Component Side)

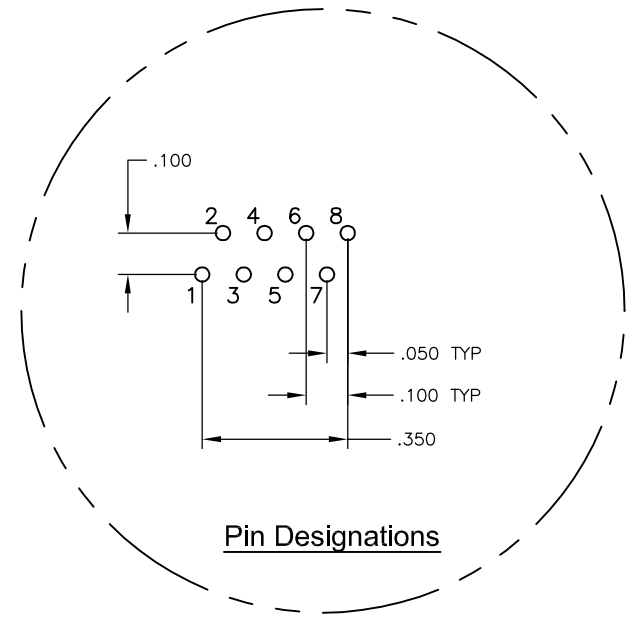

Pin Designations

 OBSOLETE PARTS: OBSOLETE CIS STREAMLINING PER D.RENAUD/D.SINISI

THIS DRAWING IS A CONTROLLED DOCUMENT.		DRW: M. HOSER/R.GRZYBOWSKI	TRP connector
DIMENSIONS: INCHES		CHK: D. FAROLE	Dongguan China
TOLERANCES UNLESS OTHERWISE SPECIFIED:		APPD: D. FAROLE	
0 PLC	± -	PRODUCT SPEC: 108-2100	NAME: 1X1 MAG45 (TM) MODULAR JACK, 7N2 SCHEMATIC, 714 SERIES CIRCUIT, SHIELDED, OPTIONAL DECOUPLING CAPACITOR WITH LEADS
1 PLC	± -	APPLICATION SPEC:	SIZE: A1
2 PLC	± .01		RESTRICTED TO
3 PLC	± .005		C=6605706
4 PLC	± -		
ANGLES	± -		
MATERIAL: SEE NOTE 1	FINISH: SEE NOTE 1	WEIGHT: -	SCALE: 1:1
CUSTOMER DRAWING		SHEET: 2 OF 2	REV: E