

LOC	DIST	REVISIONS			
P	LTR	DESCRIPTION	DATE	DWN	APVD
AF	50	A	INITIAL RELEASE PER ECR-13-012437	06AUG13	GRZ DZ

- 1 CONTINUOUS STRIP ON REELS WITH TERMINALS LOCATED ON 6.86±0.08 [.270±.003] CENTERS
- 2 SLOT ACCEPTS 0.25-0.32mm [#30-#28] AWG COPPER MAGNET WIRE. TWO WIRES OF THE SAME SIZE MAX PER SLOT.
- 3 IDENTIFICATION NUMBER 6 FOR THE MAGNET WIRE SLOT SIZE.
- 4 0.25 [.010] MAX CARRIER CUT-OFF
- 5 PRELIMINARY - NOT FOR PRODUCTION

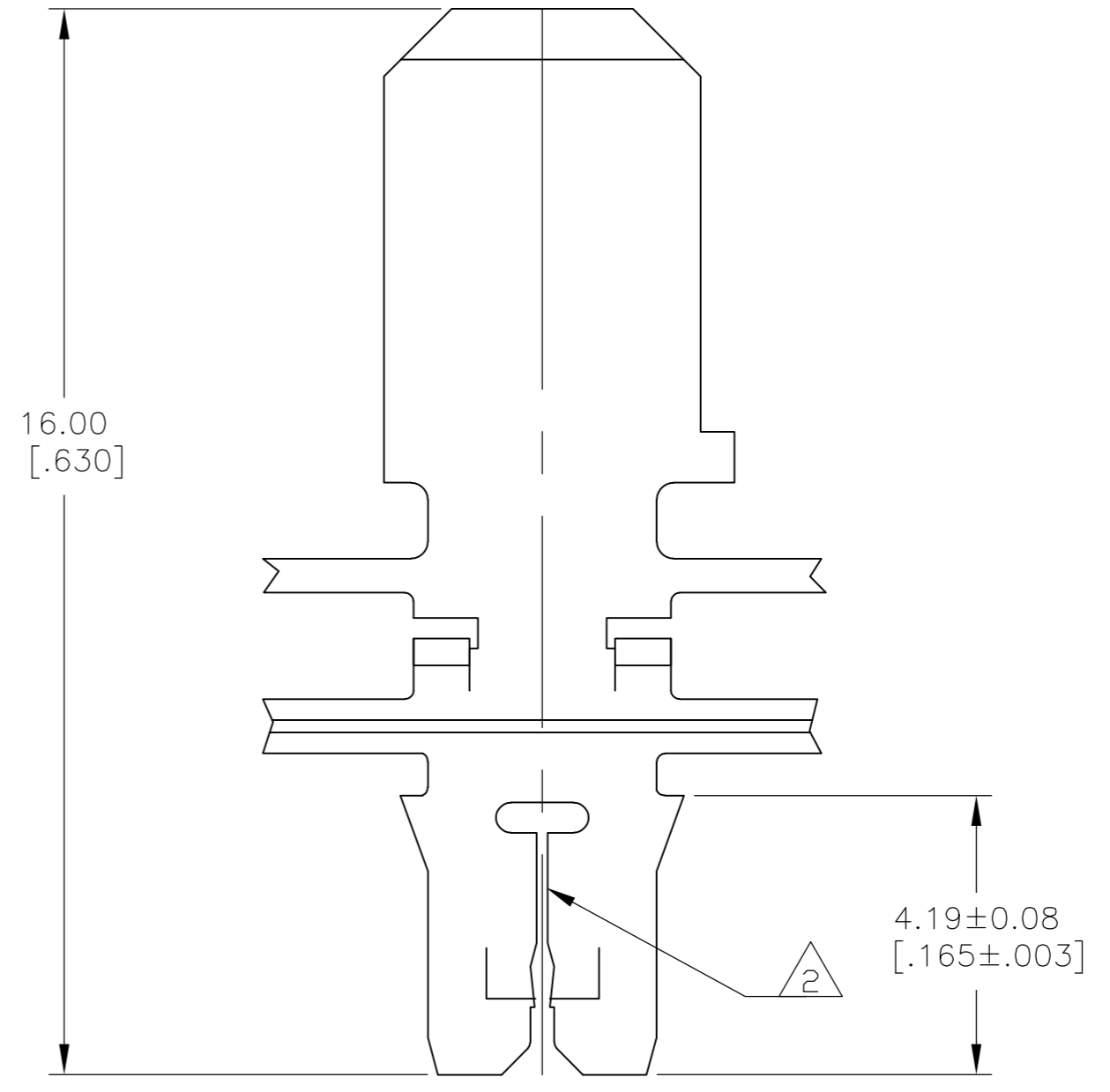
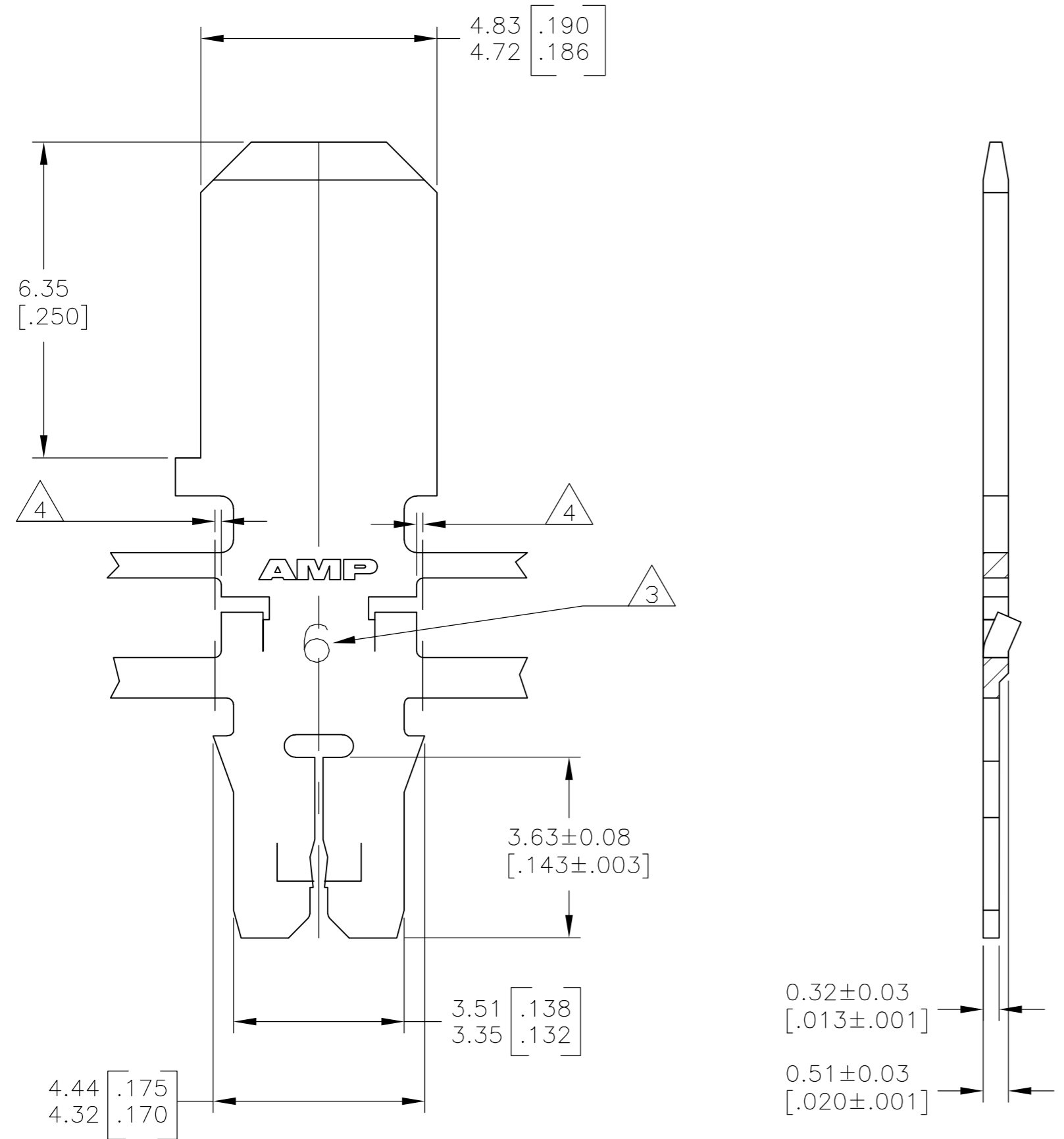

0.002032 [.000080] MIN TIN PLATE	082 PRE-MILLED BRASS	5 1742858-1
FINISH	MATERIAL	PART NO.

THIS DRAWING IS A CONTROLLED DOCUMENT.		DWN JR RUTH 27OCT10	TE Connectivity	
DIMENSIONS: MM [INCHES]		CHK KURT RANDOLPH 27OCT10	NAME KURT RANDOLPH	
TOLERANCES UNLESS OTHERWISE SPECIFIED:		APVD KURT RANDOLPH 27OCT10	PRODUCT SPEC 108-1484	
0 PLC ± -		APPLICATION SPEC 114-2140	SIZE A2	CAGE CODE 00779
1 PLC ± -		WEIGHT -	DRAWING NO. 1742858	RESTRICTED TO -
2 PLC ± 0.13 [.005]		CUSTOMER DRAWING	SCALE 10:1	SHEET 1 of 1
3 PLC ± -			REV A	
4 PLC ± -				
ANGLES ± -				
FINISH SEE TABLE				