

Distributed by:

JAMECO[®]
ELECTRONICS

www.Jameco.com ♦ 1-800-831-4242

The content and copyrights of the attached
material are the property of its owner.

Jameco Part Number 1403961

THIS DRAWING IS UNPUBLISHED. RELEASED FOR PUBLICATION
 © COPYRIGHT BY TYCO ELECTRONICS CORPORATION. ALL RIGHTS RESERVED.

Loc	DIST	REVISIONS			
P	LTR	DESCRIPTION	DATE	DWN	APVD
AD	00	U	ECO-05-007262	12JAN06	BSV MM

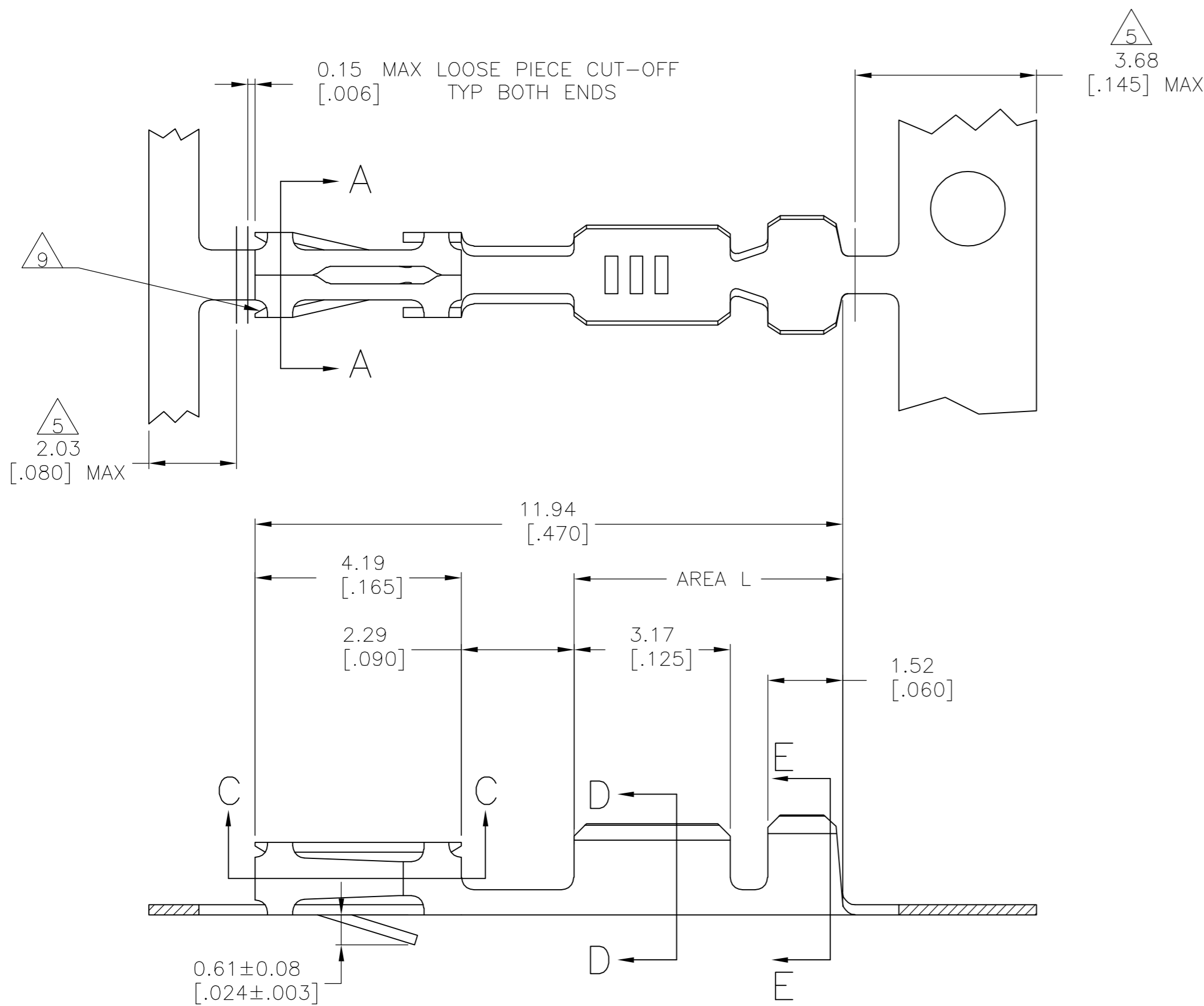

- 1 GOLD FLASH OVER 0.00127[.000050] NICKEL,.000762[.000030] GOLD ON CONTACT AREA.
- 2 GOLD FLASH OVER 0.00127[.000050] NICKEL,.000381[.000015] GOLD ON CONTACT AREA.
- 3 PREPLATED .00127-.00381 (.000050-.000150) BRIGHT TIN.
- 4 REELED FOR MINI APPLICATOR.
- 5 GOLD PLATING NOT REQUIRED - THIS AREA.
- 6 REELED FOR STANDARD APPLICATOR
- 7 0.000127[.000050] NICKEL OVER ENTIRE CONTACT, 0.000381[.000015] GOLD IN CONTACT AREA.
- 8 SHEARED EDGES ARE PERMITTED TO BE UNPLATED.
- 9 CUT OUTS ON BOX AT MANUFACTURER'S OPTION.
- 10 0.000381[.000015] GOLD IN CONTACT AREA. 0.00254-0.00508[.000100-.000200] BRIGHT TIN-LEAD IN AREA L, ALL OVER 0.000127[.000050] NICKEL.
- 11 0.000762[.000030] GOLD IN CONTACT AREA. 0.00254-0.00508[.000100-.000200] BRIGHT TIN-LEAD IN AREA L, ALL OVER 0.000127[.000050] NICKEL.
- 12 OBSOLETE PART NUMBER.
- 13 POINT OF MEASUREMENT FOR PLATING THICKNESS(INSIDE BEAMS).
- 14 0.000127[.000050] NICKEL OVER ENTIRE CONTACT, 0.000762[.000030] GOLD IN CONTACT AREA.
- 15 .000015 GOLD IN CONTACT AREA. .000100-.000200 BRIGHT TIN IN AREA L, ALL OVER .000050 NICKEL.
- 16 0.000762[.000030] GOLD IN CONTACT AREA. 0.00254-0.00508[.000100-.000200] MATTE TIN IN AREA L, ALL OVER 0.000127[.000050] NICKEL.

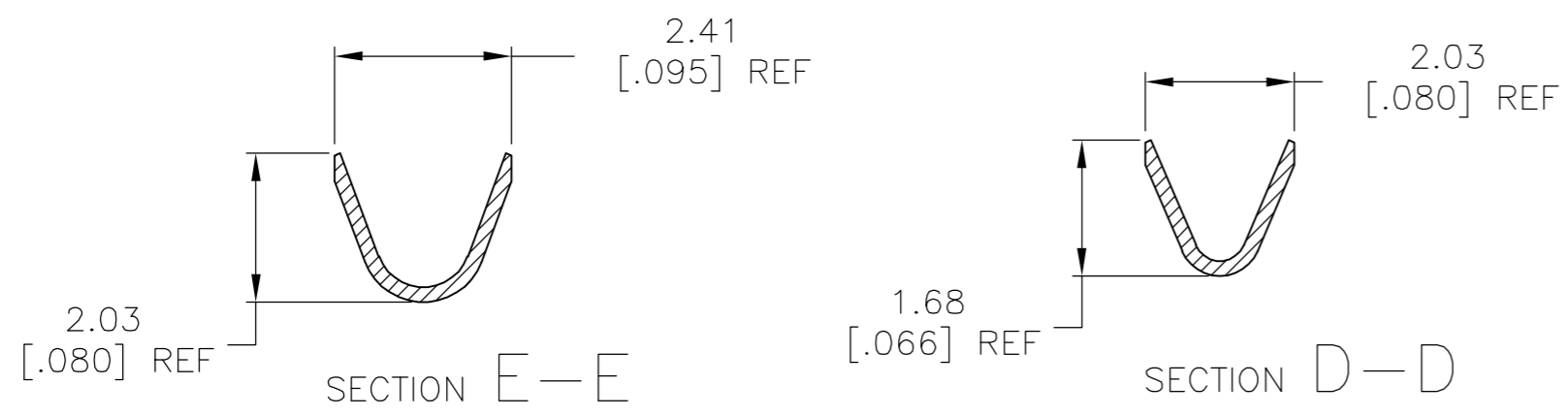
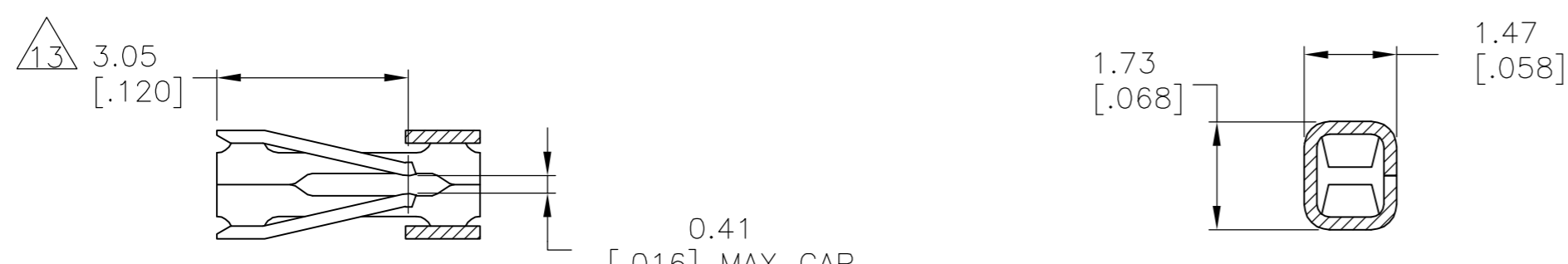

WIRE SIZE #20-#24

	LOOSE PIECE	8 16	6-87523-9
	REELED 4	8 16	6-87523-8
	LOOSE PIECE	5 15	2-87523-4
	REELED 4	8 15	2-87523-3
	REELED 6	8 7	2-87523-2
	REELED 6	8 4	2-87523-1
	LOOSE PIECE	8 11	1-87523-9
	REELED 4	8 11	1-87523-8
	LOOSE PIECE	8 10	1-87523-6
	REELED 4	8 10	1-87523-5
OBSOLETE	LOOSE PIECE	7 8	1-87523-4
OBSOLETE	REELED 4	7 8	1-87523-3
OBSOLETE	REELED 6	3	1-87523-0
OBSOLETE	REELED 6	2 5	87523-9
OBSOLETE	REELED 6	1 5	87523-8
	LOOSE PIECE	2 5	87523-7
	LOOSE PIECE	3	87523-6
	REELED 4	3	87523-5
	REELED 4	2 5	87523-4
	LOOSE PIECE	1 5	87523-3
	REELED 4	1 5	87523-2
	DESCRIPTION	FINISH	PART NUMBER

THIS DRAWING IS A CONTROLLED DOCUMENT.

DIMENSIONS: mm [INCHES]	TOLERANCES UNLESS OTHERWISE SPECIFIED: 0 PLC ± - 1 PLC ± - 2 PLC ± 0.13[.005] 3 PLC ± - 4 PLC ± - ANGLES ± -	DWN E.BRANDBERG 5-5-94 CHK B. STAUCH 5-5-94 APVD B.STAUCH 5-5-94 PRODUCT SPEC APPLICATION SPEC WEIGHT -	tyco Electronics Tyco Electronics Corporation Harrisburg, Pa 17105-3608
MATERIAL CU-SN-P, ALY 521	SEE TABLE	NAME CONTACT, MOD IV CRIMP SNAP-IN RECEPTACLE	SIZE A2 CAGE CODE 00779 DRAWING NO C=87523 RESTRICTED TO -
CUSTOMER DRAWING		SCALE 10:1	SHEET 1 OF 1 REV U