

THIS DRAWING IS UNPUBLISHED. RELEASED FOR PUBLICATION  
 © COPYRIGHT BY TYCO ELECTRONICS CORPORATION. ALL RIGHTS RESERVED.

LOC		DIST		REVISIONS			
P	LTR	DESCRIPTION	DATE	DWN	APVD		
FT	0	AL	REVISED PER 0G3B-1173-04	1/5/05	SS	GS	

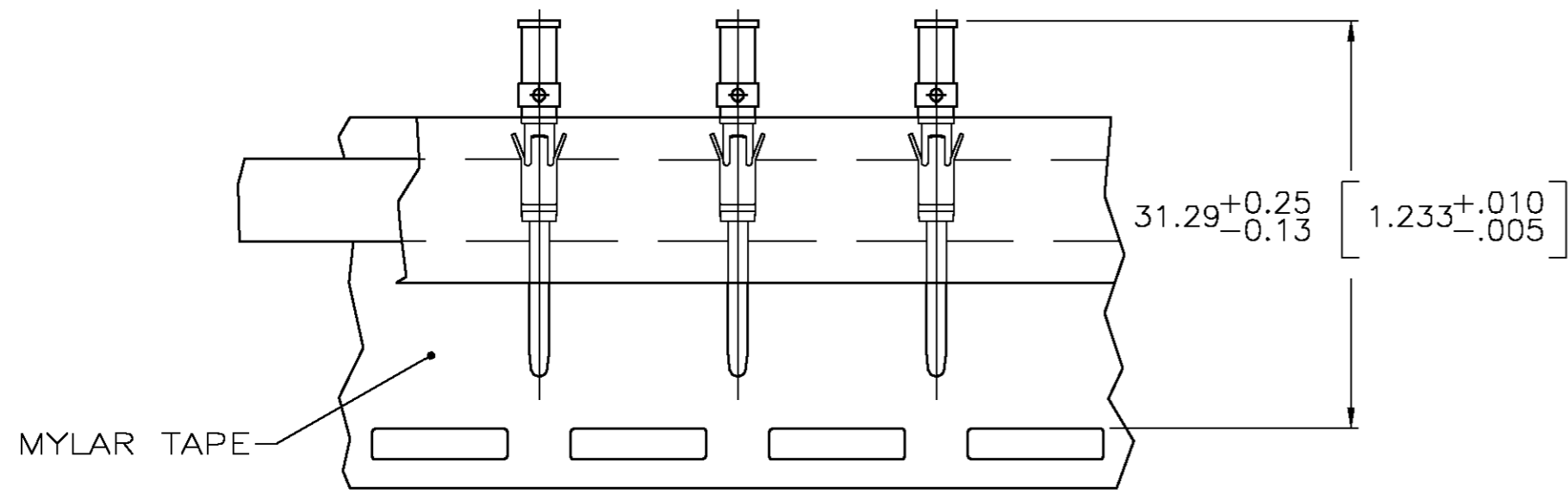
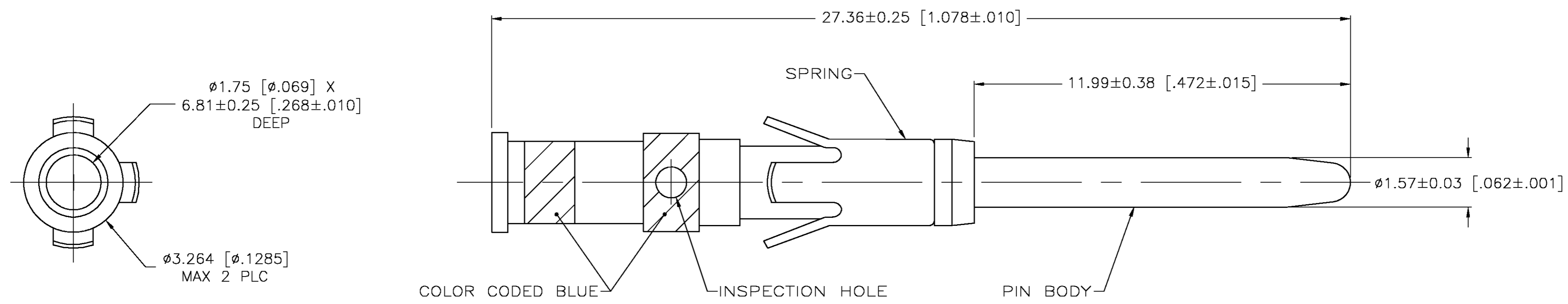

TAPE MTG DETAIL  
SCALE 2:1

- NOTES:
- 1 0.76um [.000030] MIN GOLD OVER 1.27um [.000050] MIN NICKEL.
  - 2 1.27um [.000050] MIN TIN-LEAD OVER 1.2um [.000050] MIN NICKEL.
  - 3 WHEN ORDERING CONTACT ASSEMBLY ON TAPE, ORDER BY THE TAPE NUMBER PLUS PACKAGING CODE AS FOLLOWS:
    - 1. FOR USE WITH AMP TAPETRONIC, PNEUMATIC TOOL
      - A. 1000 PARTS TO A BOX ADD PACKAGING CODE: 1MBOX
    - 2. FOR USE WITH 4/8 INDENT STRIPPER CRIMPER
      - A. 1000 PARTS TO A REEL ADD PACKAGING CODE: 1MREEL
      - B. 5000 PARTS TO A REEL ADD PACKAGING CODE: 5MREEL
  - 4. CONTACT ACCEPTS 16-18 WIRE SIZE.
  - 5 7.62 um [.000300] MIN 60/40 MATTE TIN-LEAD OVER 1.27 um [.000050] MIN NICKEL.
  - 6 7.62um[.000300] MIN 93/7 TIN/LEAD OVER 1.27um[.000050] MIN NICKEL.
  - 7 NO COLOR CODED BANDS.
  - 8 7.62um[.000300] MIN TIN OVER 1.27um[.000050] MIN NICKEL.

STANDARD	8/7	1-200336-7
STANDARD	6/7	1-200336-6
STANDARD	5/7	1-200336-5
SMALL PACK	1	1-200336-4
STANDARD	2	1-200336-3
TAPE MTG (SEE DETAIL) 3	1	200336-6
STANDARD	1	200336-1
PACKAGING TYPE	PIN BODY FINISH	PART NO.

OBSOLETE

THIS DRAWING IS A CONTROLLED DOCUMENT.		DWN D.GELTZ 04/06/93	Tyco Electronics Corporation Harrisburg, PA 17105	
DIMENSIONS: MM		CHK R.STONE 4-26-93	NAME CONTACT ASSEMBLY, PIN, #16, TYPE II	
TOLERANCES UNLESS OTHERWISE SPECIFIED: 0 PLC ± - 1 PLC ± - 2 PLC ± - 3 PLC ± - 4 PLC ± - ANGLES ± -		APVD -	PRODUCT SPEC -	APPLICATION SPEC -
MATERIAL PIN BODY: COPPER ALLOY SPRING: STAINLESS STL		FINISH PIN BODY: SEE TABLE	WEIGHT -	SIZE A2
CUSTOMER DRAWING		CAGE CODE 00779	DRAWING NO C=200336	RESTRICTED TO -
SCALE 10:1		SHEET 1 OF 1	REV AL	