

Distributed by:

JAMECO[®]
ELECTRONICS

www.Jameco.com ♦ 1-800-831-4242

The content and copyrights of the attached
material are the property of its owner.

Jameco Part Number 750531

THIS DRAWING IS UNPUBLISHED. RELEASED FOR PUBLICATION
 © COPYRIGHT BY TYCO ELECTRONICS CORPORATION. ALL RIGHTS RESERVED.

LOC	DIST	REVISIONS					
AJ	16	P	LTR	DESCRIPTION	DATE	DWN	APVD
			Y	REV PER OS14-0453-04	9-29-05	CJL	GM

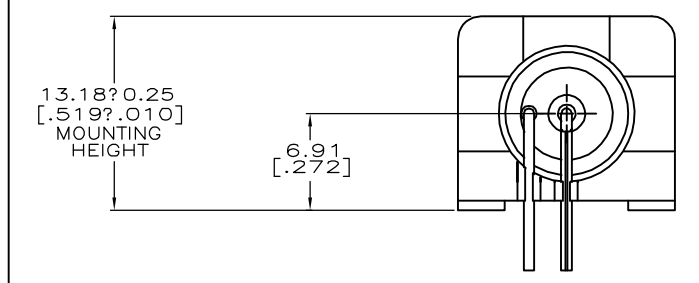

VIEW B
(SAME AS VIEW A EXCEPT AS SHOWN)

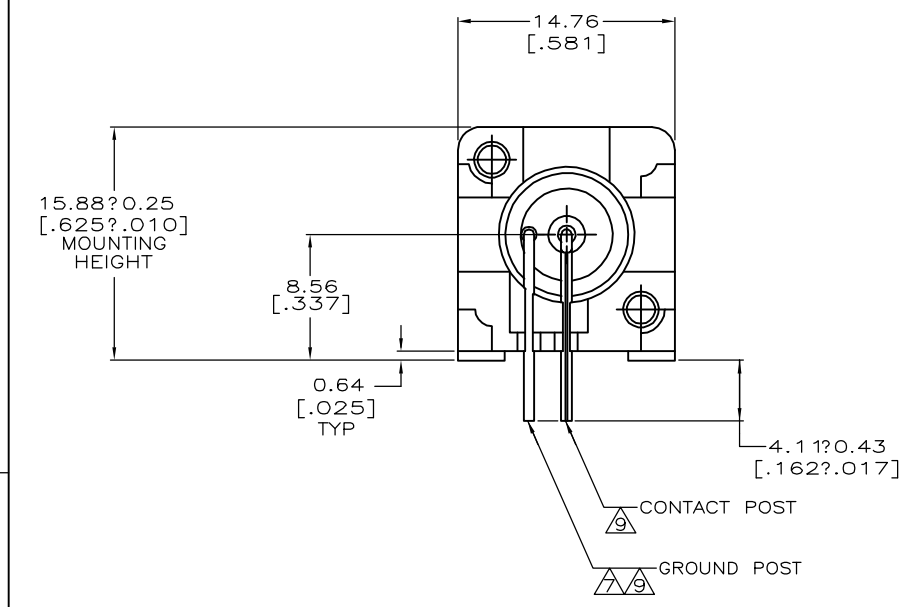

VIEW A

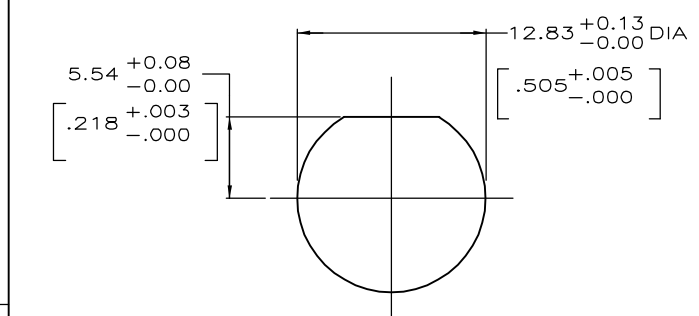
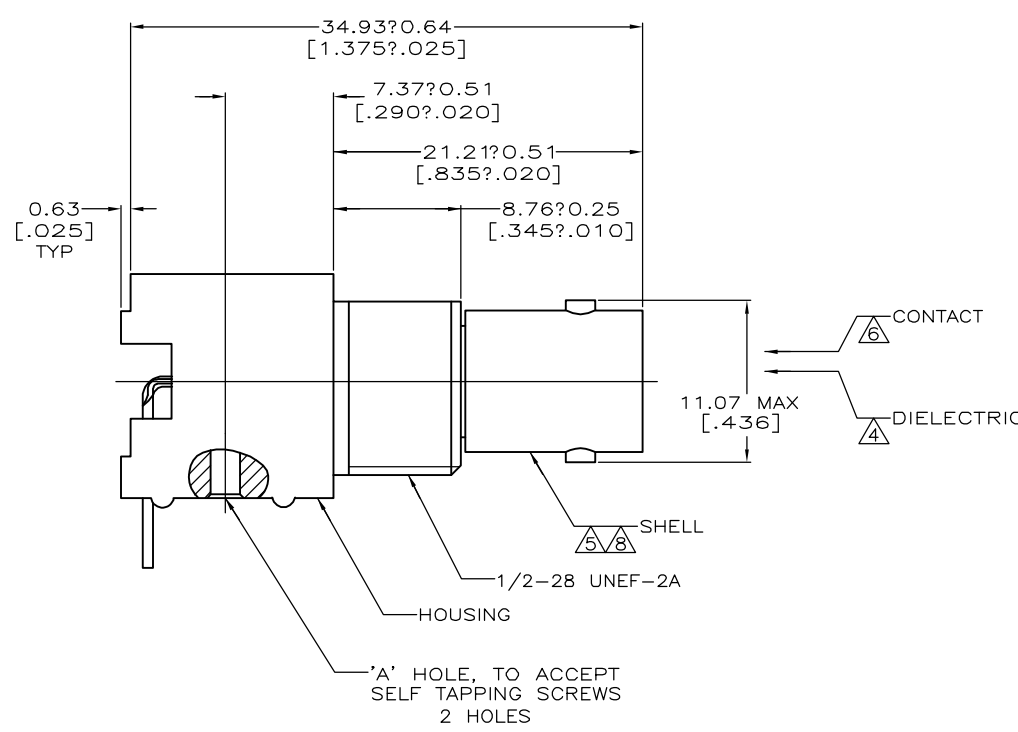
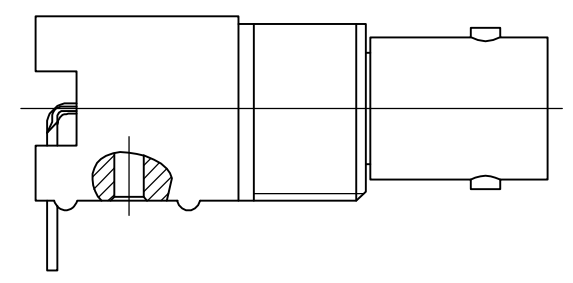

RECOMMENDED PANEL CUTOUT

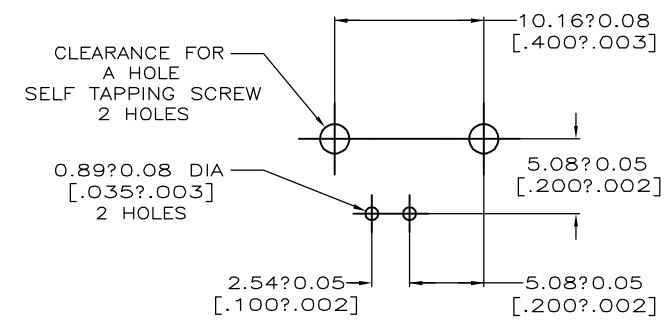

PCB CONFIGURATION

- 1 POLYESTER PBT PER MIL-M-24519, TYPE GPT-15F, UL94V-O RATED, COLOR:NATURAL
- 2 POLYESTER PBT PER MIL-M-24519, TYPE GPT-15F, UL94V-O RATED, COLOR:BLACK
- 3 POLYESTER PBT PER MIL-M-24519, TYPE GPT-15F, UL94V-O RATED, COLOR:BLUE
- 4 POLYMETHYLPENTENE, GENERAL PURPOSE.
- 5 ZINC PER QQ-Z-363.
- 6 PHOSPHOR BRONZE PER QQ-B-750.
- 7 BRASS PER ASTM-B-453.
- 8 NICKEL PLATE PER QQ-N-290, 3.81 μm [.000150] MINIMUM THICK.
- 9 TIN PLATE PER ASTM-B-545, 3.81 μm [.000150] MINIMUM THICK.
- 10 GOLD PLATE PER MIL-G-45204, 0.76 μm [.000030] MINIMUM THICK.
- 11 SILVER PLATE PER QQ-S-365, 2.54 μm [.000100] MINIMUM THICK.
- 12. SEE INSTRUCTION SHEET 2769.

SUPERSEDED BY 226990-7	B	M2.6	10	11	226990-8
OBSOLETE	B	#2-56	9	11	226990-7
	A	#2-56	10	11	226990-6
SUPERSEDED BY 226990-3	A	#2-56	11	11	226990-5
SUPERSEDED BY 226990-6	A	#2-56	11	11	226990-4
	A	#2-56	10	11	226990-3
OBSOLETE	A	#2-56	9	11	226990-2
	A	#2-56	9	11	226990-1
	VIEW	A HOLE	CONTACT PLATING	HOUSING MATERIAL	PART NUMBER

THIS DRAWING IS A CONTROLLED DOCUMENT.		DWN B. SCOTT 04-30-91	Tyco Electronics Corporation Harrisburg, Pa 17105-3608			
DIMENSIONS: mm [INCHES]		CHK J. LIPPERT 08-06-91				
TOLERANCES UNLESS OTHERWISE SPECIFIED:		APVD A. GABANY 08-06-91	NAME JACK, PANEL, RIGHT ANGLE, 50 OHM, PCB, SERIES BNC			
0 PLC ± -		PRODUCT SPEC 108-12078	-			
1 PLC ± -		APPLICATION SPEC -	SIZE	CAGE CODE	DRAWING NO	RESTRICTED TO
2 PLC ± 0.20 [.008]		WEIGHT -	A3	00779	C-226990	-
3 PLC ± -		CUSTOMER DRAWING				
4 PLC ± -		SCALE 4:1	SHEET 1 OF 1		REV Y	
ANGLES ± -						
FINISH 1 THRU 7						
FINISH 8 THRU 11						