

THIS DRAWING IS UNPUBLISHED.

RELEASED FOR PUBLICATION

ALL RIGHTS RESERVED.

LOC GP DIST 00

REVISIONS

P	LTR	DESCRIPTION	DATE	DWN	APVD
	K	REVISED PER ECO-15-011829	09MAR2016	AP	DG

- 1 MATERIAL
 HOUSING : THERMOPLASTIC, UL94V-0, BLACK
 CONTACTS : BRASS.
 SHELL : STEEL
 SCREW : BRASS.
 BOARD LOCK : BRASS.
 SCREW OF TORQUE : 5 Kg-cm MAX.
- 2 FINISH
 CONTACT : 15µ" MIN.GOLD PLATING ON CONTACT AREA
 100µ" MIN. TIN PLATING ON SOLDER TAILS
 50µ" MIN. NICKEL UNDERPLATED OVERALL
 SHELL : 100µ" MIN NICKEL PLATING.
 SCREW : 50µ" MIN. NICKEL PLATING.
 BOARD LOCK : 50µ" MIN. NICKEL PLATING.
- 3 CHARACTERISTICS
 CURRENT RATING : 3A
 INSULATION RESISTANCE : 1000MOHMS MIN. 500VDC FOR 2MINS.
 TEMPERATURE RATING : -55DEGC ~ +105DEGC
 VOLTAGE RATING : 250VDC

4 OBSOLETE PARTS: OBSOLETE CIS STREAMLINING PER D.RENAUD/D.SINISI.

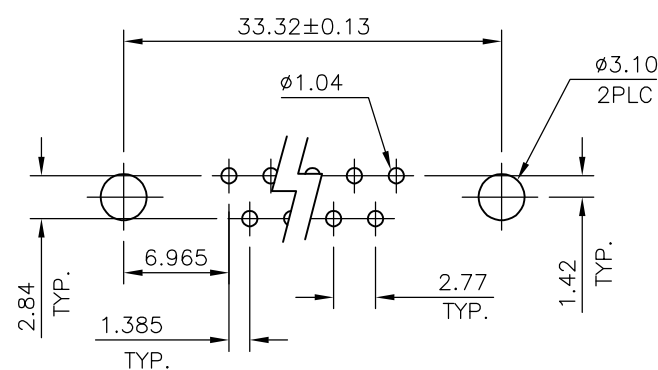
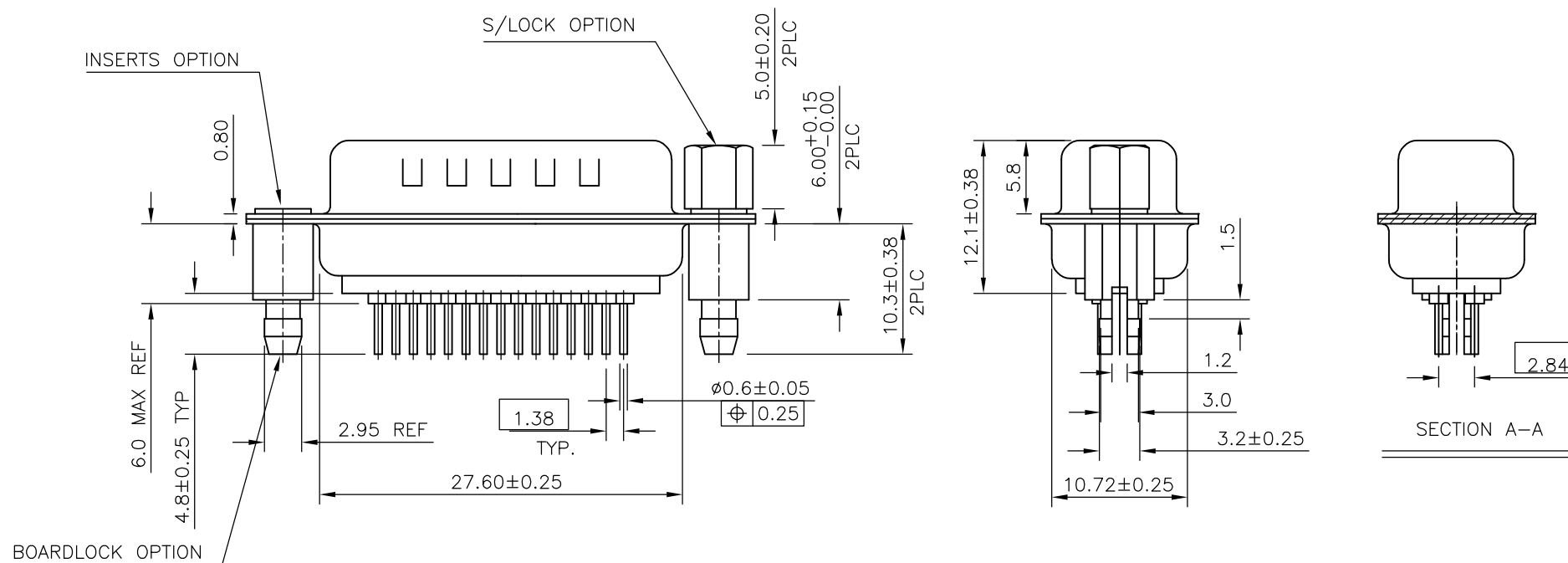
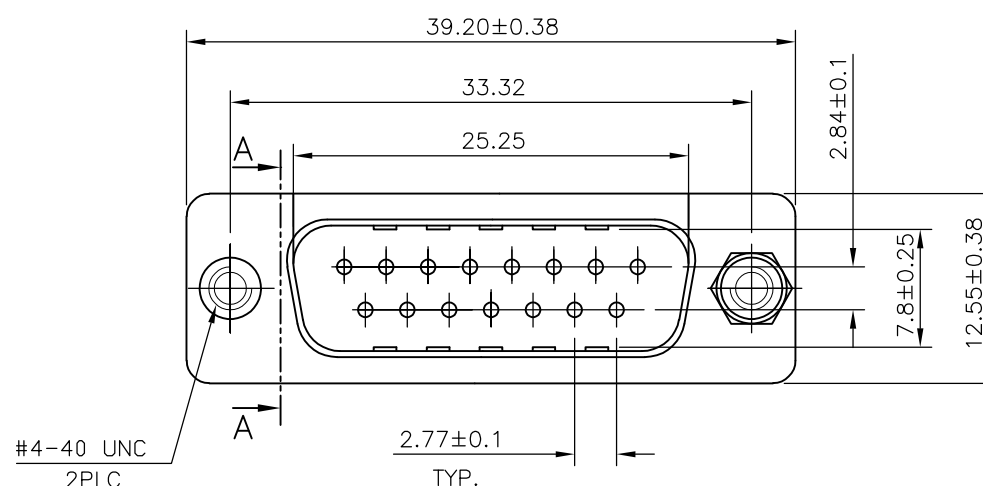

RECOMMENDED PCB LAYOUT(TOP VIEW)
(PCBTOLERANCE : ±0.05)

4	OBSOLETE	15W D PLG WITH B/L & M3 S/LOCK 15µ" GOLD	4-1634219-2
	OBSOLETE	15W D PLG WITH B/L & 4-40 S/LOCK 15µ" GOLD	3-1634219-2
4	OBSOLETE	15W D PLG WITH B/L & M3 INSERTS 15µ" GOLD	2-1634219-2
		15W D PLG WITH B/L & 4-40 INSERTS 15µ" GOLD	1-1634219-2
		DESCRIPTION	PART NO.

THIS DRAWING IS A CONTROLLED DOCUMENT.		DWN J.SANDWELL 10APR03	TE Connectivity	
DIMENSIONS: mm		CHK R.DYER 10APR03		
TOLERANCES UNLESS OTHERWISE SPECIFIED:		APVD F.WHEELER-KING 10APR03	NAME D-SUB HD20, VERTICAL, 15P PLUG CONNECTOR	
0 PLC ± - 1 PLC ± 0.25 2 PLC ± 0.15 3 PLC ± - 4 PLC ± - ANGLES ± -		PRODUCT SPEC -	SIZE A3 CAGE CODE 00779 DRAWING NO C-1634219 RESTRICTED TO -	
MATERIAL -		APPLICATION SPEC -	SCALE 2:1 SHEET 1 OF 2 REV K	
FINISH -		WEIGHT -	CUSTOMER DRAWING	

THIS DRAWING IS UNPUBLISHED.

RELEASED FOR PUBLICATION

© COPYRIGHT - By -

ALL RIGHTS RESERVED.

LOC GP DIST 00

REVISIONS

P	LTR	DESCRIPTION	DATE	DWN	APVD
-	-	SEE SHEET 1	-	-	-

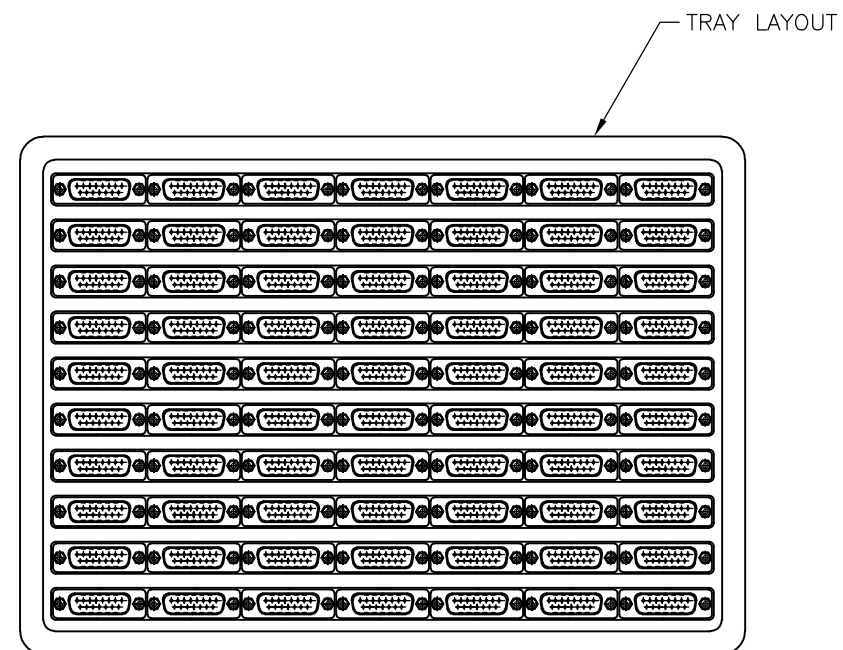
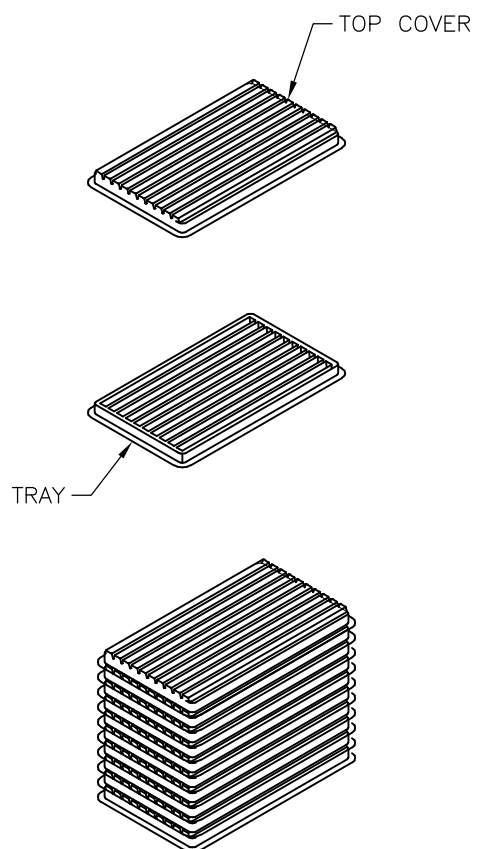

MATERIAL

- 1 TRAY: PVC
- 2 SHIPPING CARTON: CORRUGATED FIBERBOARD

DIMENSIONS

- 1 TRAY: L=310, W=230, H=21
- 2 SHIPPING CARTON: L=330, W=245, H=160

QUANTITY

- 70 PCS/TRAY
- 10 TRAY/SHIPPING CARTON

THIS DRAWING IS A CONTROLLED DOCUMENT.		DWN J.SANDWELL 10APR03	TE Connectivity											
DIMENSIONS: mm		CHK R.DYER 10APR03												
TOLERANCES UNLESS OTHERWISE SPECIFIED:		APVD F.WHEELER-KING 10APR03	NAME D-SUB HD20, VERTICAL, 15P PLUG CONNECTOR											
<table border="0"> <tr><td>0 PLC</td><td>± -</td></tr> <tr><td>1 PLC</td><td>± 0.25</td></tr> <tr><td>2 PLC</td><td>± 0.15</td></tr> <tr><td>3 PLC</td><td>± -</td></tr> <tr><td>4 PLC</td><td>± -</td></tr> <tr><td>ANGLES</td><td>± -</td></tr> </table>		0 PLC				± -	1 PLC	± 0.25	2 PLC	± 0.15	3 PLC	± -	4 PLC	± -
0 PLC	± -													
1 PLC	± 0.25													
2 PLC	± 0.15													
3 PLC	± -													
4 PLC	± -													
ANGLES	± -													
MATERIAL -		FINISH -	APPLICATION SPEC -	SIZE A3	CAGE CODE 00779	DRAWING NO C-1634219	RESTRICTED TO -							
CUSTOMER DRAWING			WEIGHT -	SCALE NTS	SHEET 2 OF 2	REV K								