

THIS DRAWING IS UNPUBLISHED. RELEASED FOR PUBLICATION
 © COPYRIGHT - By - ALL RIGHTS RESERVED.

LOC	DIST	REVISIONS					
GP	00	P	LTR	DESCRIPTION	DATE	DWN	APVD
		G		REVISED PER ECO-12-014716	23AUG2012	CJV	SLB

- NOTES:
- MATERIAL**
 HOUSING : THERMOPLASTIC, UL94V-0, BLACK
 CONTACTS : BRASS.
 SHELL : STEEL
 SCREW : BRASS.
 BOARD LOCK : BRASS.
 SCREW OF TORQUE : 5 Kg-cm MAX.
 - FINISH**
 CONTACT : 15µ" MIN.GOLD PLATING ON CONTACT AREA
 100µ" MIN. TIN PLATING ON SOLDER TAILS
 50µ" MIN. NICKEL UNDERPLATED OVERALL
 SHELL : 60µ" MIN. TIN PLATING
 SCREW : 50µ" MIN. NICKEL PLATING.
 BOARD LOCK : 50µ" MIN. NICKEL PLATING.
 - CHARACTERISTICS**
 CURRENT RATING : 3A
 INSULATION RESISTANCE : 1000MOHMS MIN, 500VDC FOR 2MINS.
 TEMPERATURE RATING : -55DEGC ~ +105DEGC
 VOLTAGE RATING : 250VDC

⚠ OBSOLETE PARTS: OBSOLETE CIS STREAMLINING PER D.RENAUD/D.SINISI

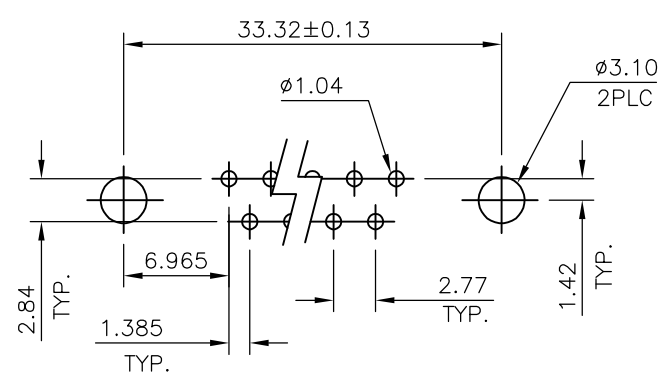
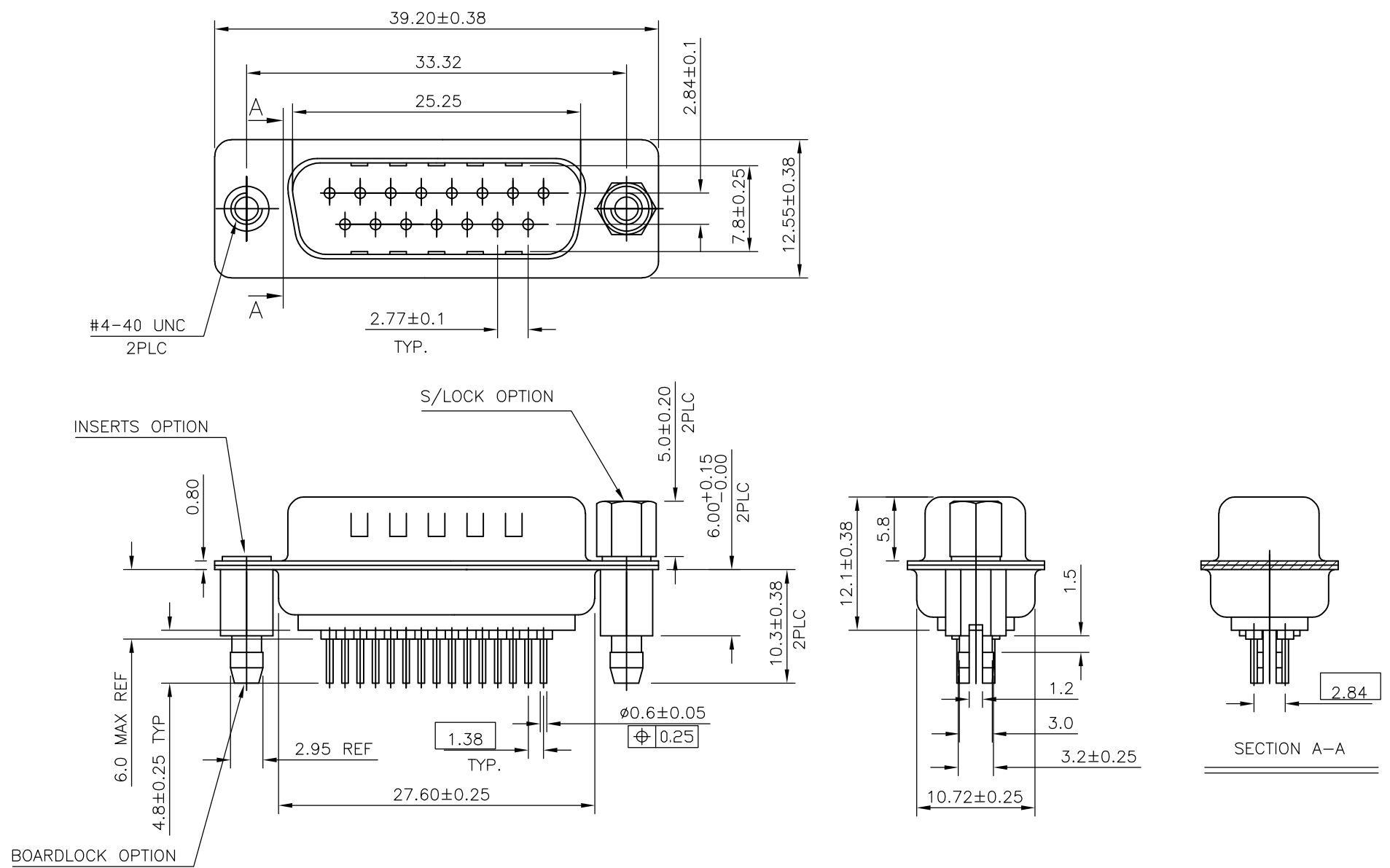

4	OBSOLETE	15W D PLG WITH B/L & M3 S/LOCK 15µ" GOLD	4-1634219-2
		15W D PLG WITH B/L & 4-40 S/LOCK 15µ" GOLD	3-1634219-2
4	OBSOLETE	15W D PLG WITH B/L & M3 INSERTS 15µ" GOLD	2-1634219-2
		15W D PLG WITH B/L & 4-40 INSERTS 15µ" GOLD	1-1634219-2
		DESCRIPTION	PART No.

THIS DRAWING IS A CONTROLLED DOCUMENT. DIMENSIONING AND TOLERANCING PER ASME Y14.5M-2009		DWN J.SANDWELL 10APR03	TE Connectivity					
DIMENSIONS: MM 		CHK R.DYER 10APR03						
TOLERANCES UNLESS OTHERWISE SPECIFIED: 0 PLC ± - 1 PLC ± 0.25 2 PLC ± 0.15 3 PLC ± - 4 PLC ± - ANGLES ± -		APVD F.WHEELER-KING 10APR03	NAME D-SUB HD20, VERTICAL, 15P PLUG CONNECTOR					
MATERIAL -		PRODUCT SPEC -	APPLICATION SPEC -	SIZE A3	CAGE CODE 00779	DRAWING NO C-1634219	RESTRICTED TO -	
FINISH -		WEIGHT -		CUSTOMER DRAWING		SCALE 2:1	SHEET 1 OF 2	REV G

THIS DRAWING IS UNPUBLISHED.

RELEASED FOR PUBLICATION

© COPYRIGHT - By -

ALL RIGHTS RESERVED.

LOC GP DIST 00

REVISIONS

P	LTR	DESCRIPTION	DATE	DWN	APVD
-	-	SEE SHEET 1	-	-	-

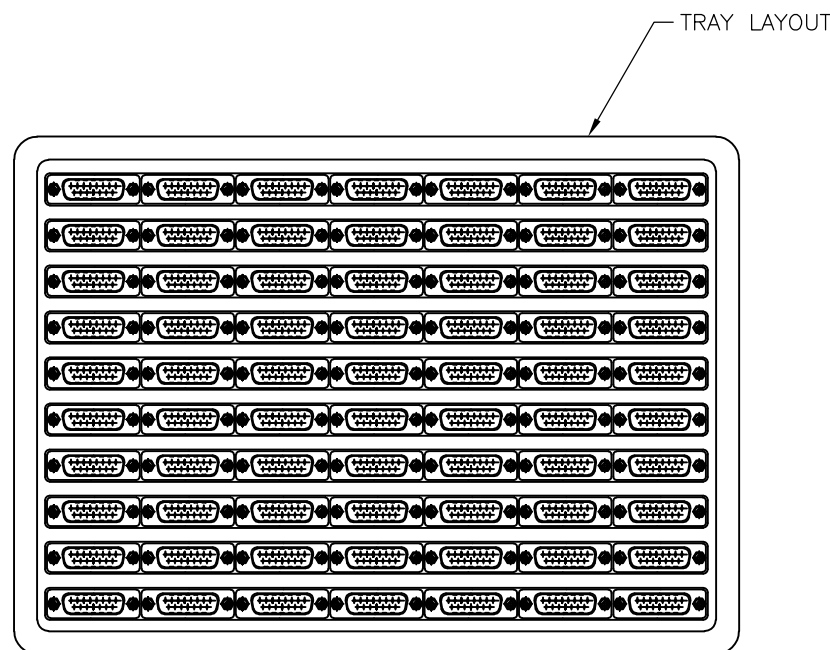
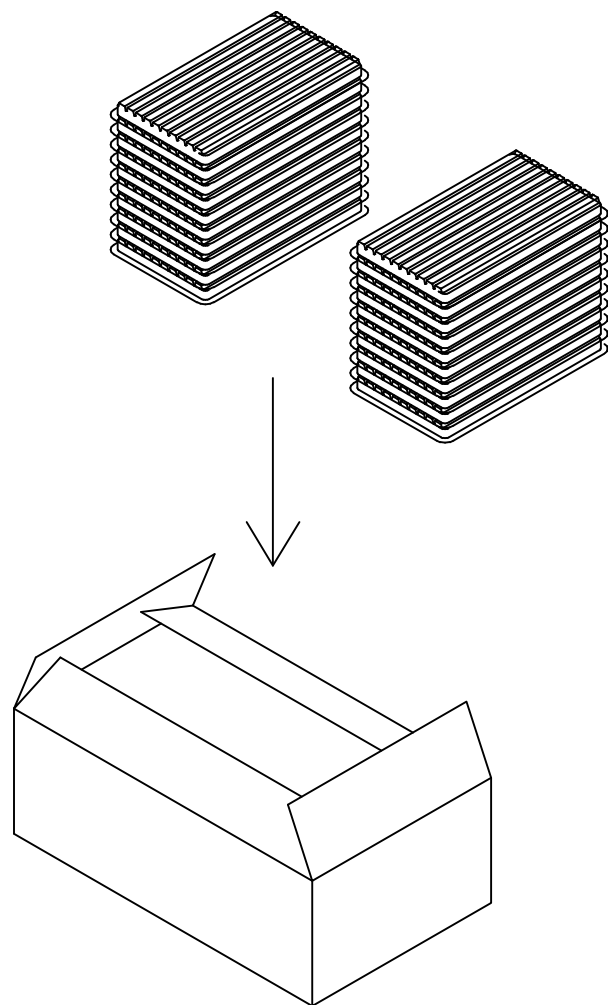
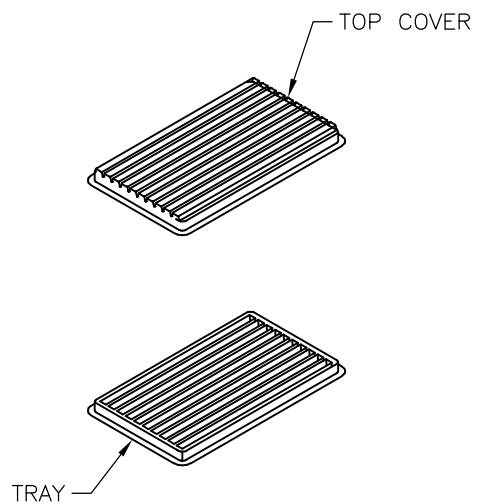

NOTES:

MATERIAL

- 1. TRAY: PVC
- 2. SHIPPING CARTON: CORRUGATED FIBERBOARD

DIMENSIONS

- 1. TRAY: L=310, W=230, H=21
- 2. SHIPPING CARTON: L=330, W=245, H=160

QUANTITY

- 70 PCS/TRAY
- 10 TRAY/SHIPPING CARTON

THIS DRAWING IS A CONTROLLED DOCUMENT. DIMENSIONING AND TOLERANCING PER ASME Y14.5M-2009		DWN J.SANDWELL 10APR03	 TE Connectivity														
DIMENSIONS: MM		CHK R.DYER 10APR03															
TOLERANCES UNLESS OTHERWISE SPECIFIED:		APVD F.WHEELER-KING 10APR03	NAME D-SUB HD20, VERTICAL, 15P PLUG CONNECTOR														
<table border="1"> <tr> <td>0 PLC</td> <td>± -</td> </tr> <tr> <td>1 PLC</td> <td>± 0.25</td> </tr> <tr> <td>2 PLC</td> <td>± 0.15</td> </tr> <tr> <td>3 PLC</td> <td>± -</td> </tr> <tr> <td>4 PLC</td> <td>± -</td> </tr> <tr> <td>ANGLES</td> <td>± -</td> </tr> </table>		0 PLC	± -	1 PLC	± 0.25	2 PLC	± 0.15	3 PLC	± -	4 PLC	± -	ANGLES	± -	PRODUCT SPEC -	SIZE A3		
0 PLC	± -																
1 PLC	± 0.25																
2 PLC	± 0.15																
3 PLC	± -																
4 PLC	± -																
ANGLES	± -																
MATERIAL -		FINISH -	APPLICATION SPEC -	CAGE CODE 00779	DRAWING NO C-1634219												
		WEIGHT -	RESTRICTED TO -														
CUSTOMER DRAWING			SCALE NTS	SHEET 2 OF 2	REV G												