



Have a Question?
 Chat with a Product
 Information Specialist

What can we help you find?

[Products](#) |
 [Industries](#) |
 [Resources](#) |
 [About TE](#) |
 [My Account](#) |
 [Innovation](#) |
 [Support Center](#)

321887 Product Details

[Share](#) |
 [Print](#) |
 [Email](#)



321887

TE Internal Number: 321887

Active

Ring and Spade Tongue Terminals

Always EU RoHS/ELV Compliant (Statement of Compliance)

Product Highlights:

- Terminal Shape = Ring Tongue
- Receptacle Style = Straight
- Body Style = DIAMOND GRIP, STRATO-THERM
- Barrel Type = Closed Barrel
- Wire/Cable Type = Regular Wire

[View all Features](#)

Quick Links

- ▶ [Pricing & Availability](#)
- ▶ [Search for Tooling](#)
- ▶ [Product Feature Selector](#)
- ▶ [Contact Us About This Product](#)

[Add to My Part List](#) |
 [Request Sample](#) |
 [Find Similar Products](#) |
 [Buy Product](#)

Documentation & Additional Information	
<p>Product Drawings:</p> <ul style="list-style-type: none"> • TERMINAL, RING TONGUE, STRATOTHERM, DIAMOND GRIP, WI... (PDF, English) <p>Catalog Pages/Data Sheets:</p> <ul style="list-style-type: none"> • None Available <p>Product Specifications:</p> <ul style="list-style-type: none"> • None Available <p>Application Specifications:</p> <ul style="list-style-type: none"> • STRATO-THERM Terminals, Splices, and Spare Wire Caps (PDF, English) <p>Instruction Sheets:</p> <ul style="list-style-type: none"> • None Available <p>CAD Files:</p> <ul style="list-style-type: none"> • None Available 	<p>Related Products:</p> <ul style="list-style-type: none"> • Tooling

[List all Documents](#)

Product Features (Please use the Product Drawing for all design activity)	
<p>Product Type Features:</p> <ul style="list-style-type: none"> • Receptacle Style = Straight • Barrel Type = Closed Barrel • Wire/Cable Type = Regular Wire • Insulation = No • Insulation Support = Insulation Support • Stud Size = 4 • Shape = RING-053 • Heavy Duty = No • Finish = None • Color Code = Orange <p>Termination Features:</p> <ul style="list-style-type: none"> • Wire/Cable Size (CMA) = 509 – 3,260 <p>Dimensions:</p> <ul style="list-style-type: none"> • Insulation Diameter (mm [in]) = 2.67 - 3.56 [.105 - .140] • Stud Diameter (mm [in]) = 3.02 [0.119] • Tongue Material Thickness (mm [in]) = 0.84 [0.033] <p>Body Features:</p> <ul style="list-style-type: none"> • Body Style = DIAMOND GRIP, STRATO-THERM • Wire Range (mm [AWG]) = 0.30-1.42² [22-16] • Material = Nickel 	<p>Contact Features:</p> <ul style="list-style-type: none"> • Terminal Shape = Ring Tongue <p>Industry Standards:</p> <ul style="list-style-type: none"> • Government/Industry Qualification = No • RoHS/ELV Compliance = RoHS compliant, ELV compliant • Lead Free Solder Processes = Not relevant for lead free process • RoHS/ELV Compliance History = Always was RoHS compliant <p>Conditions for Usage:</p> <ul style="list-style-type: none"> • High Temperature Rating (°C [°F]) = 649 [1200] <p>Packaging Features:</p> <ul style="list-style-type: none"> • Packaging Method = Loose Piece <p>Other:</p> <ul style="list-style-type: none"> • Brand = AMP

THIS DRAWING IS UNPUBLISHED. RELEASED FOR PUBLICATION
 © COPYRIGHT - By - ALL RIGHTS RESERVED.

LOC	DIST	REVISIONS			
P	LTR	DESCRIPTION	DATE	DWN	APVD
G	14	E2	REVISED PER ECO-12-004648	08MAR12	KH DR

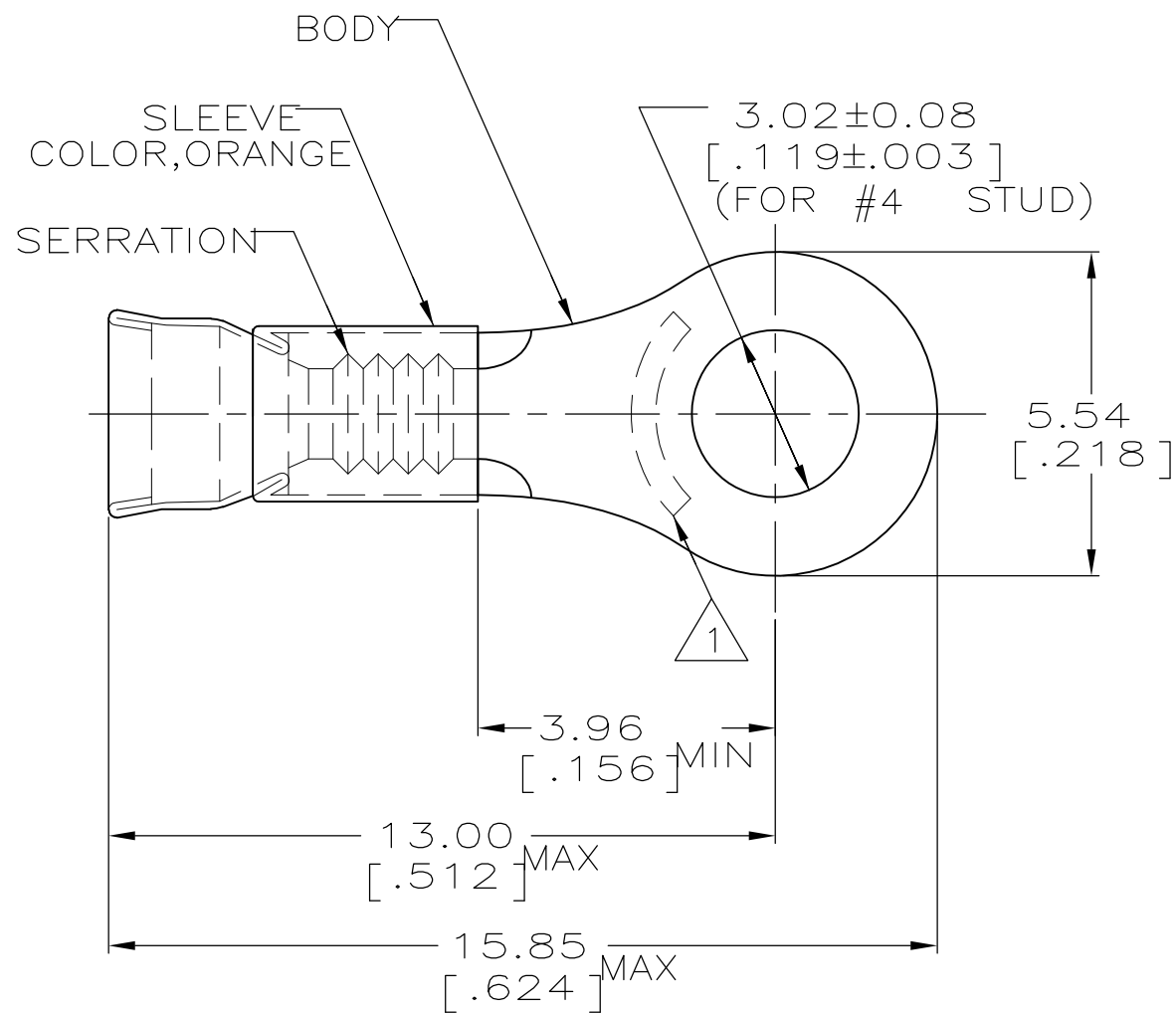

- 1. STAMP AMP 22-18 APPROX AS SHOWN
 22-16 TERMINALS ARE STAMPED 22-18 IN ACCORDANCE WITH MILITARY SPEC SAE AS7928
 COMMERCIAL WIRE RANGE IS 22-16
- 2. WIRE INSUL DIA, 2.67-3.56 [.105-.140]
- 3. TONGUE MATL THK, 0.79±0.05 [.031±.002]
- 4. BODY: GOLD PLATE 0.00127[.000050] MIN EXT. THK PER ASTM B488, TYPE1, CODE C OVER NICKEL FLASH PER SAE AMS QQ-N-290, OVER WOODS NICKEL FLASH PER ASTM B558.
- 5. NOTE DELETED.

4	260°C [500°F]	1000	LOOSE PIECE	321887-1
--	649°C [1200°F]	1000	LOOSE PIECE	321887
FINISH	MAX OPERATING TEMPERATURE	QTY	PACKAGE TYPE	PART NO

AMP INCORPORATED CUSTOMER SERVICE SYSTEM		MAX RECOMMENDED OPERATING TEMPERATURE: SEE TABLE	THIS DRAWING IS A CONTROLLED DOCUMENT.		DWN L OLMEDA 10OCT94	TE Connectivity				
FOR ADDITIONAL PRODUCT INFORMATION OR COPIES OF DRAWINGS AND TECHNICAL DOCUMENTS	PRODUCT INFORMATION CENTER 1-800-522-6752	VOLTAGE RATING: -	DIMENSIONS: mm [INCHES]	TOLERANCES UNLESS OTHERWISE SPECIFIED:	CHK M ELLIS 10OCT94					NAME
FOR APPLICATION TOOLING INFORMATION	TOOLING ASSISTANCE CENTER 1-800-722-1111	CIRCULAR MIL AREA: 0.26mm ² -1.65mm ² [509-3260]		0 PLC ± - 1 PLC ± - 2 PLC ± 0.20 [.008] 3 PLC ± - 4 PLC ± - ANGLES ± -	APVD S BORTNER 10OCT94	TERMINAL, RING TONGUE, STRATOTHERM, DIAMOND GRIP, WIRE SIZE, 22-16 AWG				
FOR ORDER ENTRY	1-800-526-5142	STRANDED WIRE		MATERIAL BODY, NI PER ASTM B162 SLEEVE, NI SIL PER ASTM B122	FINISH SEE TABLE	PRODUCT SPEC -	SIZE A3	CAGE CODE 00779	DRAWING NO C-321887	RESTRICTED TO -
					WEIGHT -	CUSTOMER DRAWING		SCALE 6:1	SHEET 1 OF 1	REV E2