

Distributed by:

**JAMECO**<sup>®</sup>  
ELECTRONICS

**www.Jameco.com ♦ 1-800-831-4242**

The content and copyrights of the attached  
material are the property of its owner.

Jameco Part Number 752131

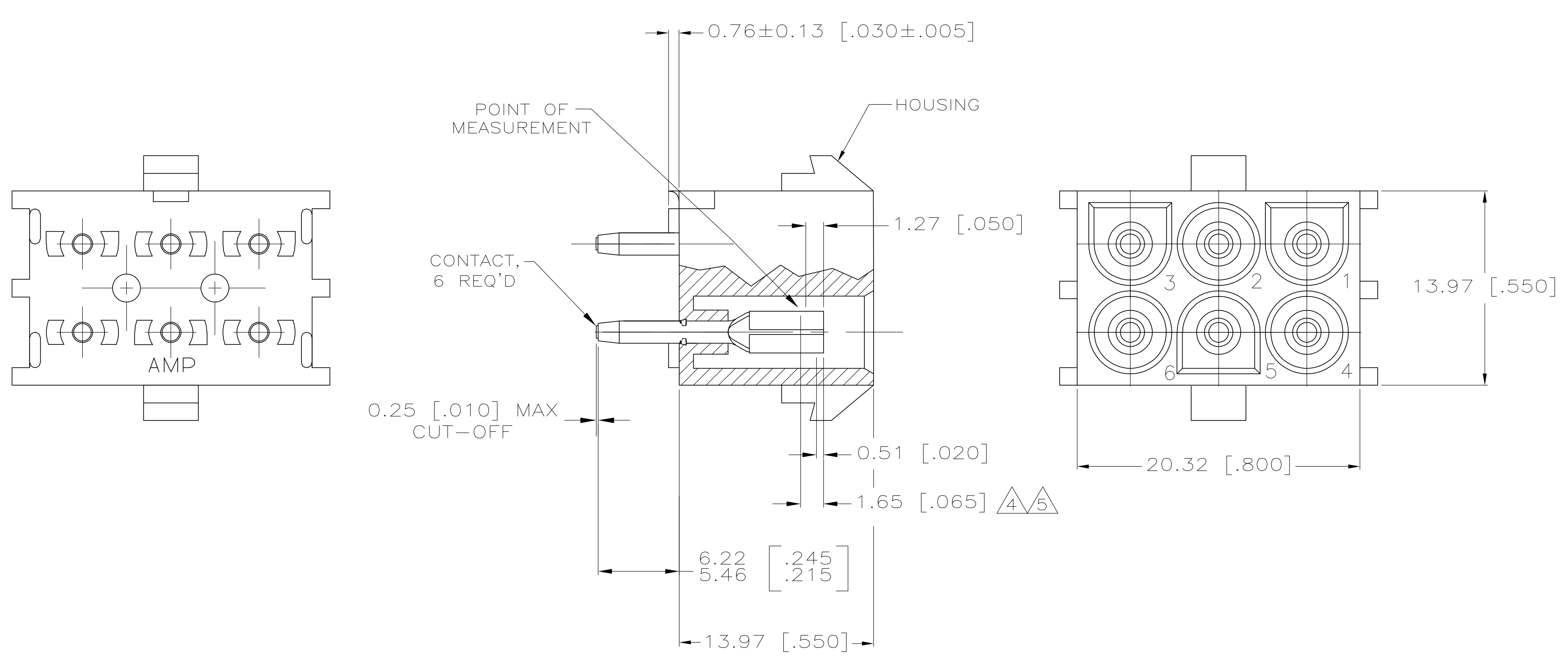

1. MATES WITH AMP CONNECTOR PART NO 480704.
2. FLAME RETARDANT CLASSIFICATION OF MATERIAL IS 94V-2.
3. PARTS MUST COMPLY WITH AMP SOLDERABILITY SPEC 109-11-3.
4. CONTACT IS STAMPED FROM PRE-PLATED STOCK WHICH IS PLATED OVERALL WITH 0.00127 [.000050] NICKEL, THEN STRIPED WITH 0.00076 [.000030] GOLD IN CONTACT AREA INDICATED AND TIN-LEAD ON SOLDER TAIL END.
5. CONTACT IS PLATED OVERALL WITH 0.00127 [.000050] NICKEL, THEN 0.00076 [.000030] GOLD OVER CONTACT LENGTH INDICATED AND MATTE TIN ON SOLDER TAIL END.

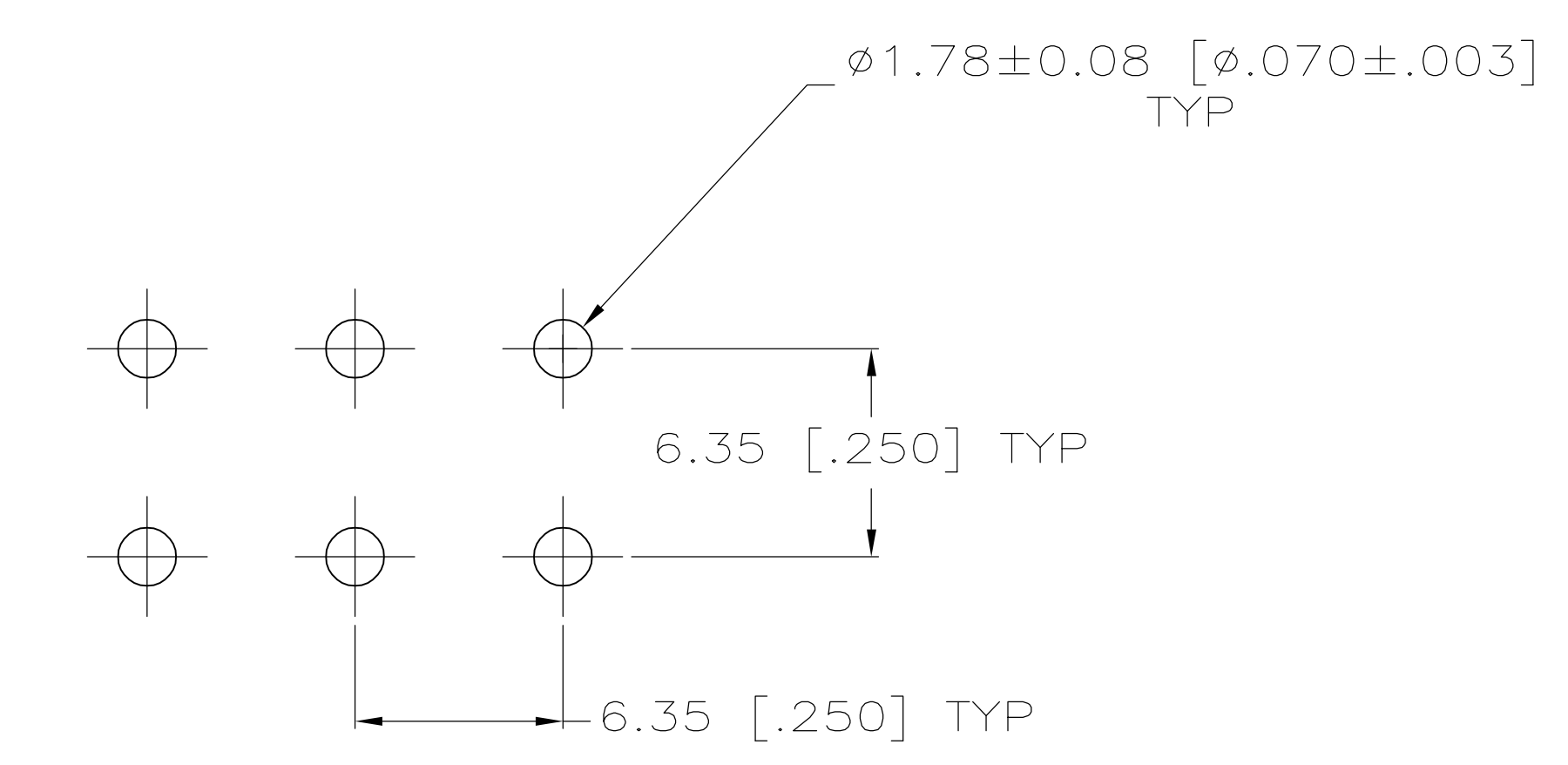

RECOMMENDED LAYOUT FOR 1.58 [.062] THICK PC BOARD

PH BRZ GOLD 5	NYLON, NATURAL 2	350989-5
PH BRZ TIN	NYLON, NATURAL 2	350989-4
PH BRZ GOLD 4	NYLON, NATURAL 2	350989-3
CONTACT	HOUSING	PART NO

THIS DRAWING IS A CONTROLLED DOCUMENT.

DIMENSIONS: mm (INCHES)	TOLERANCES UNLESS OTHERWISE SPECIFIED: 0 PLC ± 1 PLC ± 2 PLC ± 3 PLC ± 0.13 [.005] 4 PLC ± ANGLES ± FINISH	OWN: K. WHITAKER 11OCT2005 CHK: S. RIDGILL 11OCT2005 APVD: S. RIDGILL 11OCT2005	NAME: S. RIDGILL PRODUCT SPEC: APPLICATION SPEC SIZE: A1 CAGE CODE: 00779 DRAWING NO: 350989	Tyco Electronics Corporation Harrisburg, PA 17105-3608 SOCKET HEADER ASSEMBLY, 6 CIRCUIT, LONG TAIL, UNIVERSAL MATE-N-LOK (TM)	RESTRICTED TO: CUSTOMER DRAWING
----------------------------	---	---	--	--	---------------------------------

MATERIAL: SEE TABLE

SCALE: 5:1 SHEET: 1 OF 1 REV: G1

