



Mini AMP-In , Short Version

1. INTRODUCTION

This specification covers the requirements for application of AMP-IN * Terminal Short Version . These requirements are applicable to automatic and semi-automatic (AMP-O-Electric) machine crimping tools . The contacts are designed to be inserted into Printed Circuit Board holes .

Note : All dimensions are given in MM (Milimeters) unless otherwise specified .

2. REFERENCE MATERIAL

- a) AMP Product Specification no. 108-37010 covers performance requirements for AMP Miniature , AMP-IN Short Version .
- b) Customer Drawings for specific products are available from the responsible AMP Engineering Department . The information on Customer Drawings takes priority if there is a conflict with this specification or with any other technical documentation supplied by AMP Incorporated .
- c) Product Part Number 444082 and Product Code 2042 are assigned to the Mini AMP-In product line . Use of these numbers will identify the product line and expedite your inquiries through an AMP service network established to help you obtain product and tooling information . Such information can be obtained through a local AMP Representative (Field Sales Engineer , Field Application Engineer , etc) .

3. PRODUCT FEATURES

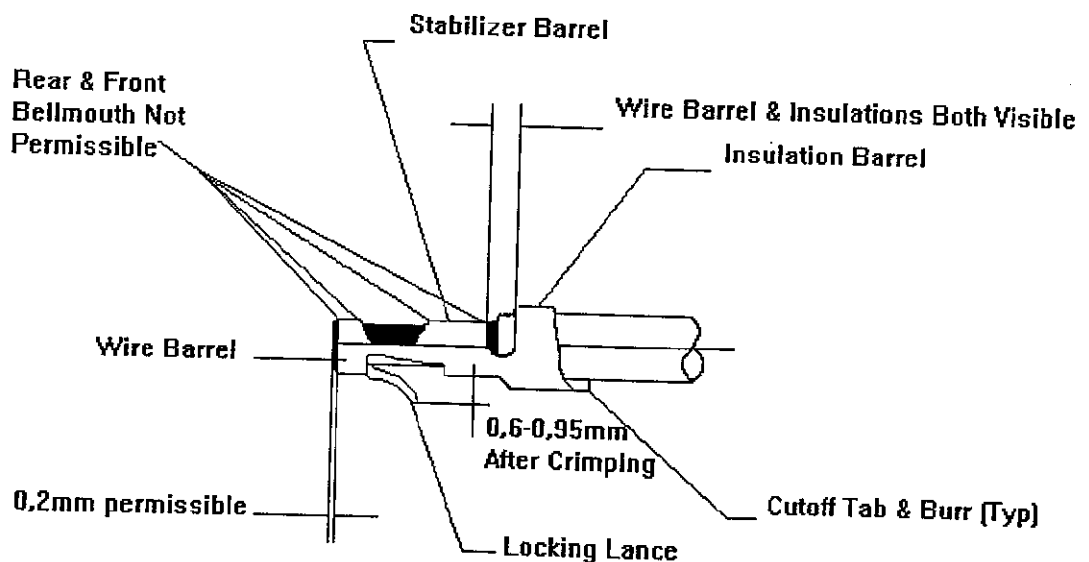

Prepared by : Cláudio C.Cassali

Approved by : Celso C.Lima

AMP do Brasil Conectores Elétricos e Eletrônicos Ltda.

© Copyright 1995 by AMP do Brasil Ltda.
All international rights reserved .

* Trademark
| Indicates changes

This specification is a controlled document .
For latest revision , call the AMP FAX .

4. REQUIREMENTS

4.1 Wire Preparation requirements are as follows :

- a) The contacts will accept wires ranging in size from 22-26 awg .
- b) Wire insulation diameter shall have maximum dimensions according to the wire sizes indicated in Figure 2 .
- c) Wire strip length shall be according to the wire sizes as indicated in Figure 2 .
- d) Reasonable care shall be taken during the stripping operation to ensure the conductor is not nicked , scrapped or cutted .

4.2 Crimping requirements are as follows :

- a) Contacts shall be crimped in accordance with the specifications listed in Figure 2 .

Note : Care shall be taken to ensure that the wire insulation is not cut or broken during the crimping operation and to ensure that the insulation is not crimped into the stabilizer or wire barrel .

Part Number	Wire			Wire Barrel		Stabilizer Barrel		Insul.Barrel Crimp Width	Applicator P / N
	Size awg	Insul. Dia.	Strip Length +/- 0,25 mm	Crimp Height +0,025/-0,050	Crimp Width	Crimp Height +0,025/-0,050	Crimp Width		
444082	26	1,52	4,20 mm	0,74 mm	.042F (1,07)F	0,94 mm	.042F (1,07)F	.070F (1,78)F	573865-0 (a) 573865-2 (b)
	24	mm		0,74 mm					
	22	Max.		0,94 mm					
	26	1,52	4,20 mm	0,74 mm	.042F (1,07)F	0,94 mm	.042F (1,07)F	.070F (1,78)F	573865-4 (c)
	24	mm		0,86 mm					
	22	Max.		0,94 mm					

- (a) P/N 573865-0 for UK / K Press Machine
- (b) P/N 573865-2 for AMPOMATOR Machine
- (c) P/N 573865-4 for AMPOMATOR Machine (Special Applicator)

Figure 2

- b) The following additional requirements shall apply to the completed wire barrel crimp .
 - (1) Wire barrel seam shall be completely closed with no wire strands loose or visible in the seam .
 - (2) Rear and front bellmouth not permissible .
- c) Completed crimped contacts shall have the wire located as follows :
 - Both insulation and conductor shall be visible between the insulation barrel and the wire or stabilizer barrel . Care shall be taken to ensure that the insulation is not crimped into the wire or stabilizer barrel .
- d) Carrier cutoff tab and burr requirements are as follows :
 - (1) The carrier strip cutoff tab shall have a maximum length of 0,38 .
 - (2) The burr of the cutoff tab shall be a maximum of 0,08 .
- e) Locking lance on bottom of contact shall be within limits show in Figure 1 .

5. PRINTED CIRCUIT BOARD

The printed circuit board hole size should be within the dimensions specified in Figure 3 .

Part Number	PC Board Hole Size	PC Board Thickness
444082	1,29 +/- 0,06	1,64 +/- 0,15

Figure 3

6. CLEANING AND SOLDERING

- a) Contacts shall be fluxed prior to soldering using a medium active rosin or a medium to highly active organic flux . Proper flux selection depends on the type of Printed Circuit Board and any components already mounted . Flux must also be compatible with customer's flow solder line and with manufacturing and safety requirements .
- b) Removal of fluxes , residues and activators is mandatory . Cleaning procedures are chosen by the customer and depend on the type of flux used on the solder line .
- c) AMP Corporate Bulletin no. 52 is available upon request and can be used as a guide in soldering . This bulletin gives various flux types and characteristics along with commercial designation and removal procedures . A checklist is attached to the bulletin to aid in obtaining information pertaining to soldering problems .

7. TOOLING TYPE

The AMP-O-Electric * Model K / UK Machine or the AMPOMATOR * Model T Machine with AMP Miniature Applicators may be used for crimping the contacts . Refer to the chart in Figure 2 for Applicator Part Numbers .

8. VISUAL AID

Figure 4 illustrates a properly crimped typical contact and a typical mounted contact in a PC Board . It is to be used by production personnel to visually ensure a properly assembled product .

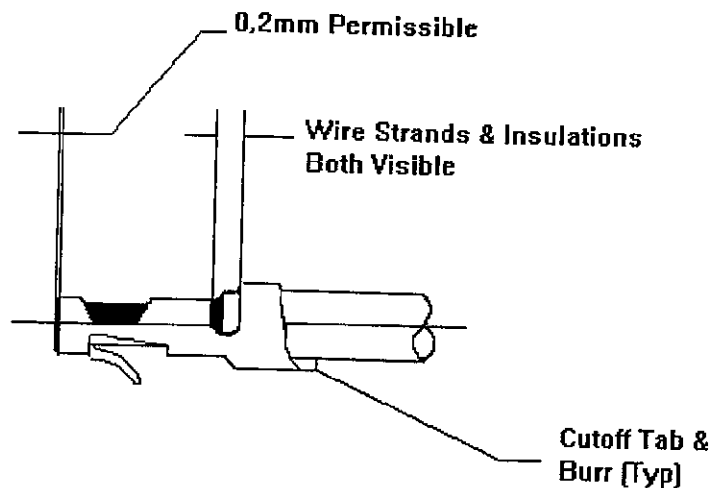

Figure 4

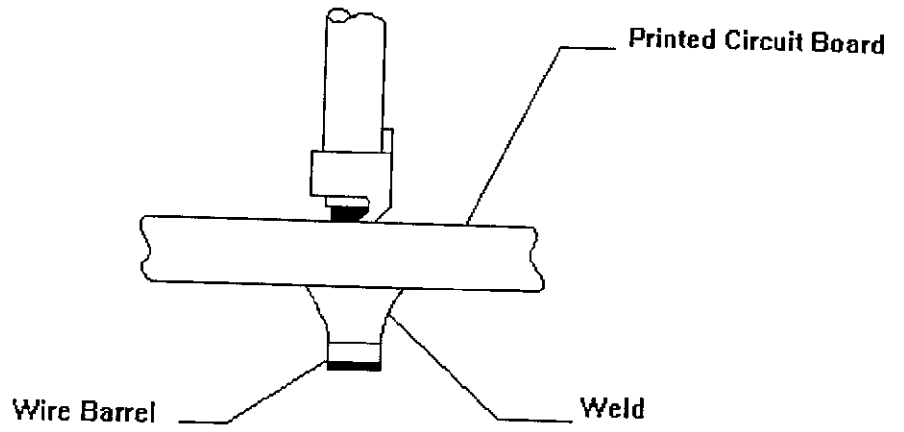

Figure 4 (cont.)

Revision Record		
Revision	Date	Description
O	13-Sep-1993	Issued
A	24-Sep-1999	LB00-0444-99

Edited by Engineering Services