

THIS DRAWING IS UNPUBLISHED. RELEASED FOR PUBLICATION
 © COPYRIGHT BY TYCO ELECTRONICS CORPORATION. ALL RIGHTS RESERVED.

LOC	DIST	REVISIONS			
P	LTR	DESCRIPTION	DATE	DWN	APVD
AD	00	R	REVISED PER EC 0512-0287-05	10DEC05	JDP AMS

- 1 MATERIAL : BRASS
- 2 FINISH : .000030 GOLD OVER .000050 NICKEL UNDERPLATE.
- 3 FINISH : .000050 GOLD OVER .000050 -.000100 NICKEL UNDERPLATE.
- 4 FINISH : .000050 -.000100 NICKEL PLATE ALL OVER.

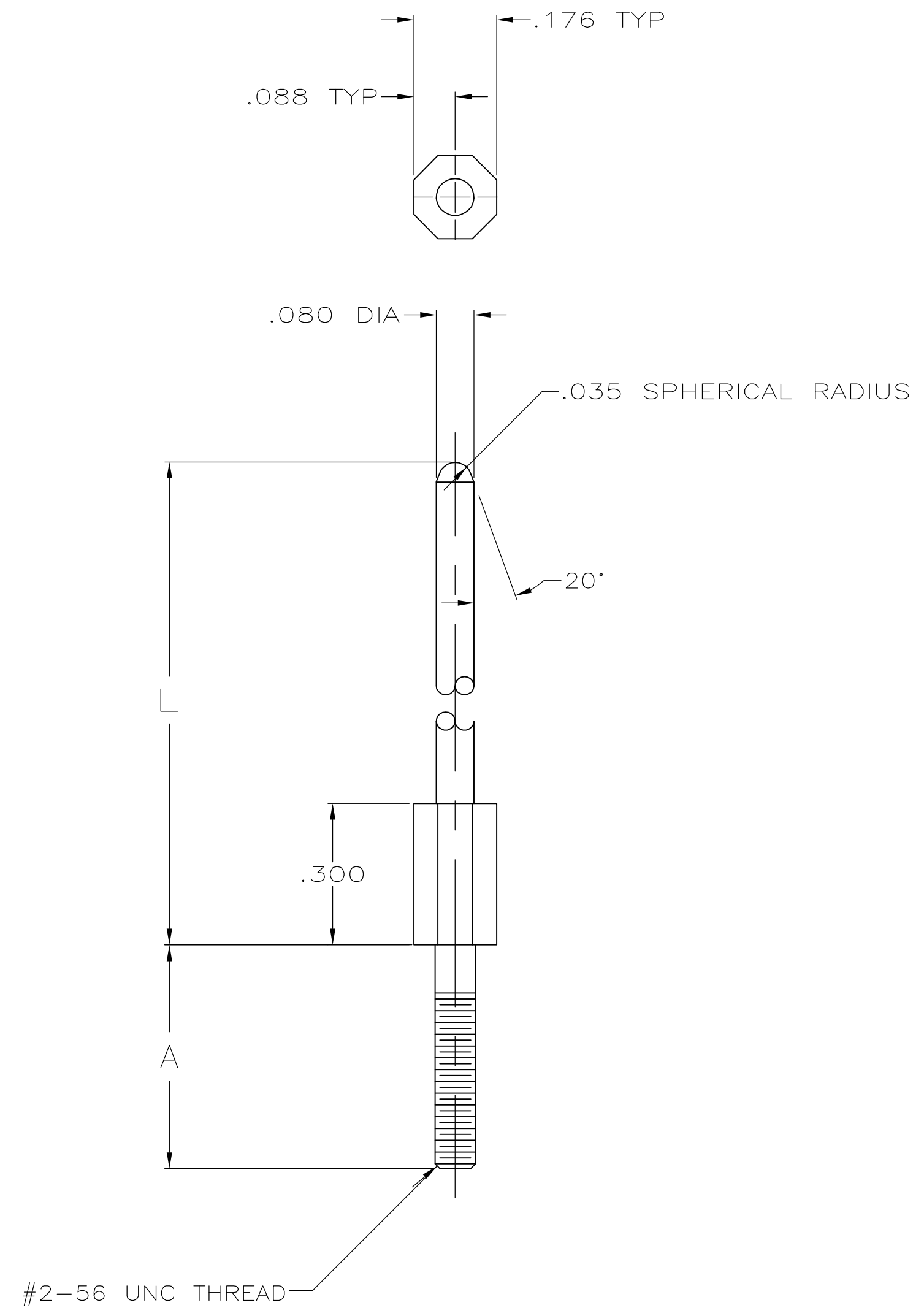

OBsolete	L	A	FINISH	PART NUMBER
OBsolete	1.025	.450	PLAIN	2-533082-0
OBsolete	.750	.475	2	1-533082-9
OBsolete	.820	.560	PLAIN	1-533082-8
OBsolete	.750	.475	PLAIN	1-533082-7
OBsolete	1.195	.690	2	1-533082-6
OBsolete	1.195	.690	PLAIN	1-533082-5
OBsolete	.850	.560	2	1-533082-4
OBsolete	.850	.560	PLAIN	1-533082-3
OBsolete	1.195	.475	4	1-533082-2
	1.025	.560	2	1-533082-1
	1.025	.560	PLAIN	1-533082-0
	1.025	.475	2	533082-9
	1.025	.475	PLAIN	533082-8
	1.195	.475	PLAIN	533082-7
	1.195	.475	2	533082-6
OBsolete	1.025	.375	3	533082-5
	1.195	.375	2	533082-4
	1.025	.375	2	533082-3
	1.195	.375	PLAIN	533082-2
	1.025	.375	PLAIN	533082-1

THIS DRAWING IS A CONTROLLED DOCUMENT.

DWN DAVID HOFFMAN 03/20/90	Tyco Electronics Corporation Harrisburg, PA 17105-3608
CHK J.D.WEARY 02/07/92	
APVD -	NAME
PRODUCT SPEC -	AMP-HDI SERIES 100 KEYING POWER PIN
APPLICATION SPEC -	SIZE A2 CAGE CODE 00779 C=533082
MATERIAL 1	WEIGHT -
FINISH 2 3 4	CUSTOMER DRAWING

RESTRICTED TO -

SCALE 4:1 SHEET 1 of 1 REV R