

SEE TABLE  
 REFER TO DETAIL FOR COLD HOLD CONFIGURATION

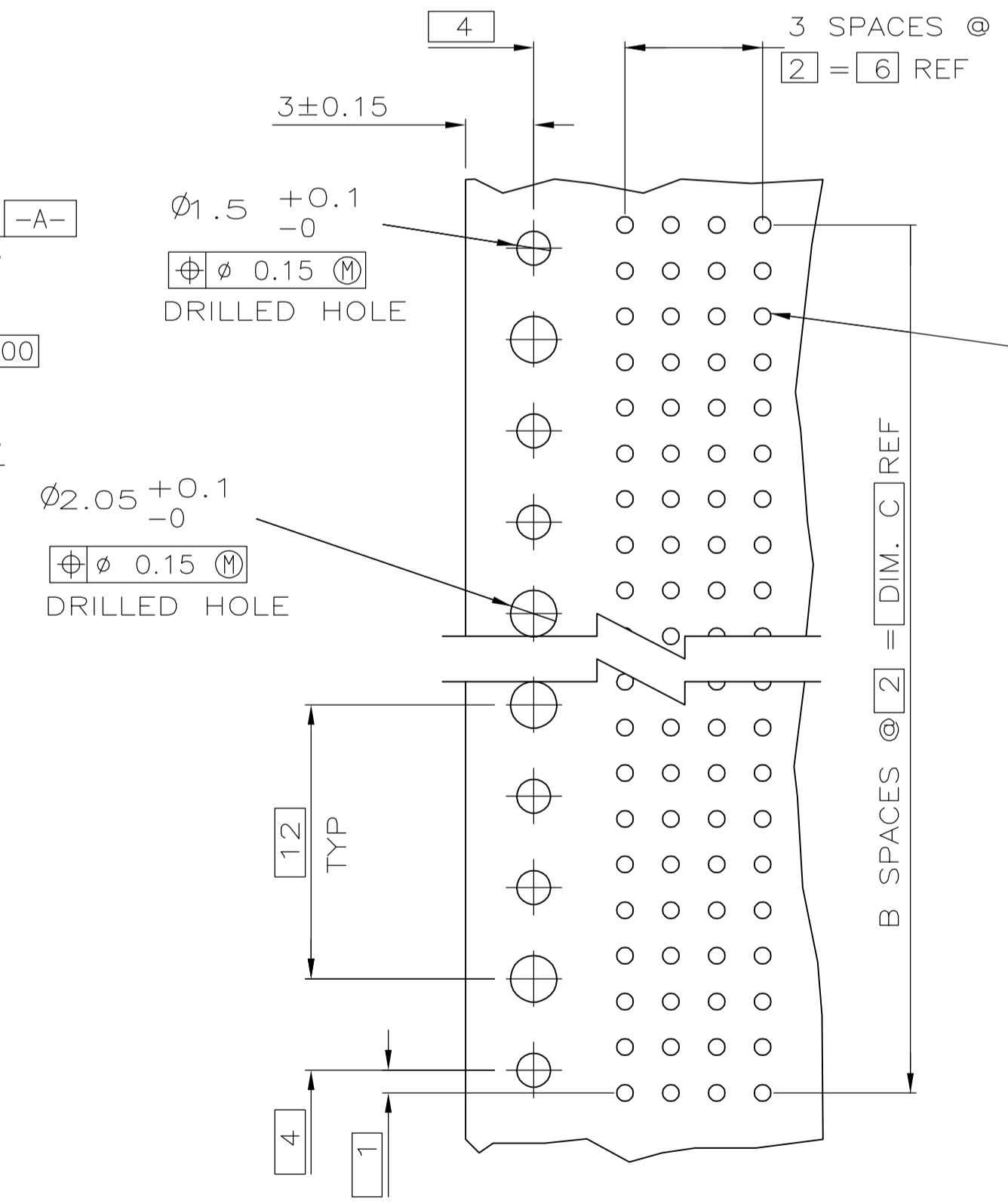

RECOMMENDED CIRCUIT PATTERN  
 PER IPC-D300 TYPE II, CLASS C  
 (COMPONENT SIDE)

- 1 HOUSING MATERIAL: LIQUID CRYSTAL POLYMER  
 COLOR: NATURAL.
- 2 CONTACT MATERIAL: PHOSPHOR-BRONZE.
- 3 CONTACT FINISH:  
 UNDERPLATE (ENTIRE CONTACT) -  
 0.00127 MIN. NICKEL  
 ON MATING SURFACES-  
 CONFORMS TO ALL TESTING SPECIFIED FOR TELCORDIA  
 UNCONTROLLED ENVIRONMENT  
 ON LEADS-  
 0.00381 MIN. TIN-LEAD, OVER UNDERPLATE  
 LUBRICATION (ENTIRE CONTACT)  
 SURFACE CONDITIONER PER AMP SPEC. 112-1002 AFTER PLATING.
- 4 PART MARKING PER AMP INCORPORATED SPECIFICATION 115-9009, LOCATED APPROXIMATELY AS SHOWN.

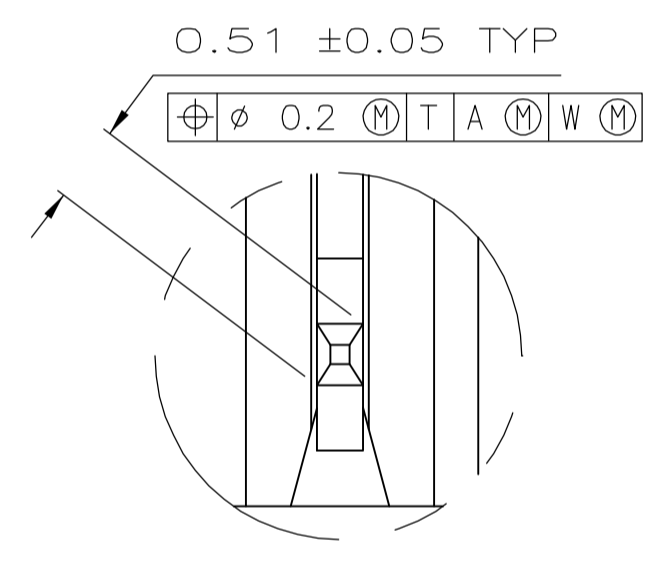

DETAIL Z  
 SCALE 20:1

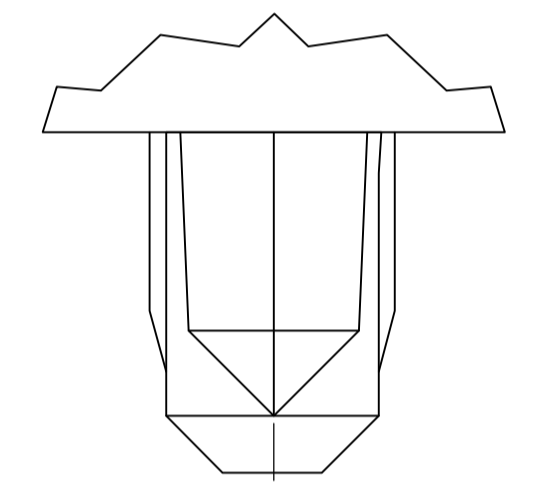

TYPICAL COLD HOLD  
 FOR ALL ASSEMBLIES

	NO	34	17	35.88	3	72	1-536507-1
	NO	130	65	131.88	3	264	1-536507-0
	NO	106	53	107.88	3	216	536507-9
	NO	118	59	119.88	3	240	536507-8
	NO	70	35	71.88	3	144	536507-7
	NO	58	29	59.88	3	120	536507-6
OBSOLETE	NO	82	41	83.88	3	168	536507-5
	NO	94	47	95.88	3	192	536507-4
	NO	46	23	47.88	3	96	536507-3
	NO	22	11	23.88	3	48	536507-2
	YES	10	5	11.88	3	24	536507-1
POSITIONING PEGS	C	B	A	FINISH	NO OF POSN	PART NUMBER	

THIS DRAWING IS A CONTROLLED DOCUMENT. DIN D.R.BENDER / 08/06/92  
 CHK S.G. / 01/26/93  
 AP'D D. PEOPLES / 01/26/93

tyco Electronics  
 Tyco Electronics Corporation  
 Harrisburg, PA 17105-3608

RECEPTACLE ASSEMBLY, SIGNAL MODULE,  
 Z-PACK 2mm FB,  
 4 ROW, 2.73mm LEAD LENGTH

SIZE: A1  
 CAGE CODE: 00779  
 DRAWING NO: 536507

RESTRICTED TO  
 CUSTOMER DRAWING  
 SCALE: 4:1  
 SHEET: 1 of 1  
 REV: AA1