

- 1 HOUSING MATERIAL: LIQUID CRYSTAL POLYMER PER ASTM D5138 LCP000 G30A 32250, COLOR: NATURAL.
- 2 CONTACT MATERIAL: PHOSPHOR-BRONZE.
- 3 CONTACT FINISH:
UNDERPLATE (ENTIRE CONTACT) - 0.00127 MIN. NICKEL
ON MATING SURFACES- CONFORMS TO ALL TESTING SPECIFIED FOR TELCORDIA UNCONTROLLED ENVIRONMENT
ON LEADS- 0.0006 MIN. TIN-LEAD, OVER UNDERPLATE
LUBRICATION (ENTIRE CONTACT) SURFACE CONDITIONER PER TE CONNECTIVITY SPEC 112-1002 AFTER PLATING.
- 4 PART MARKING PER AMP INCORPORATED SPECIFICATION 115-9009, LOCATED APPROXIMATELY AS SHOWN.
- 5 OBSOLETE PARTS: OBSOLETE CIS STREAMLINING PER D.RENAUD/D.SINISI

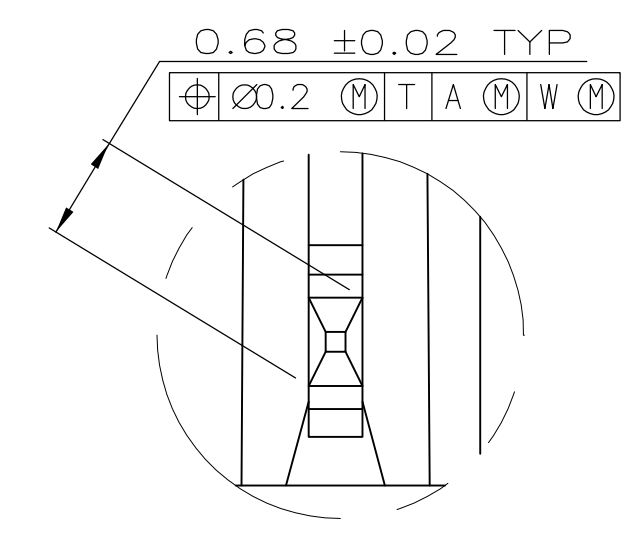

DETAIL Z
SCALE 20:1

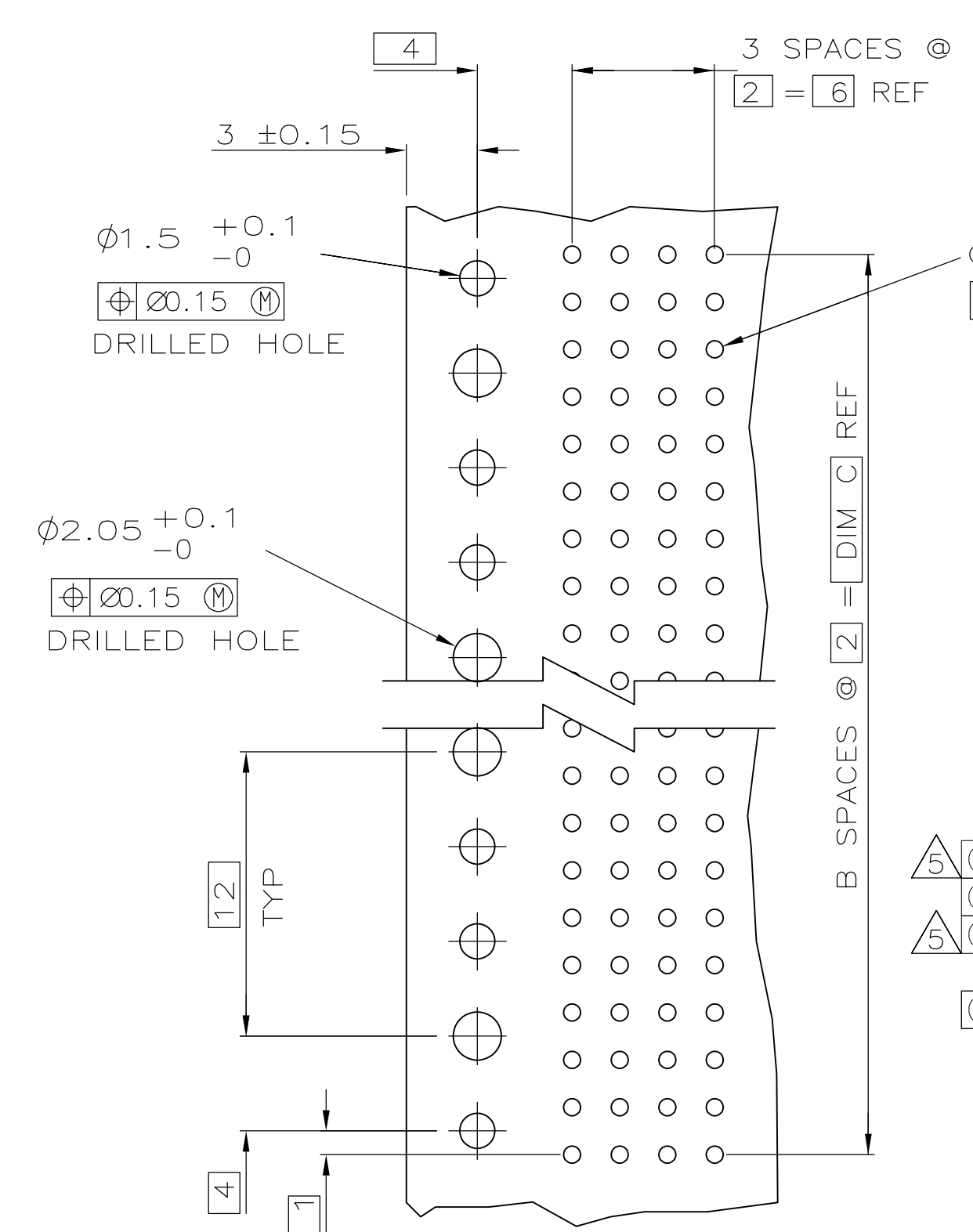

RECOMMENDED CIRCUIT PATTERN
PER IPC-D300 TYPE II, CLASS C
(COMPONENT SIDE)

	NO	34	17	35.88	72	1-536511-2
OBsolete	NO	130	65	131.88	264	1-536511-1
OBsolete	NO	106	53	107.88	216	1-536511-0
OBsolete	NO	118	59	119.88	240	536511-9
	NO	82	41	83.88	168	536511-8
OBsolete	NO	66	33	67.88	136	536511-7
	NO	58	29	59.88	120	536511-6
	NO	70	35	71.88	144	536511-5
	NO	94	47	95.88	192	536511-4
	NO	46	23	47.88	96	536511-3
	NO	22	11	23.88	48	536511-2
	YES	10	5	11.88	24	536511-1
POSITIONING PEGS	C	B	A	FINISH	NO OF POSN	PART NUMBER

THIS DRAWING IS A CONTROLLED DOCUMENT.

DIMENSIONS: mm	TOLERANCES UNLESS OTHERWISE SPECIFIED:	DIN D.R.BENDER 10/15/92	STE TE Connectivity
0 PLC ± -	1 PLC ± -	CHK S.HEADER 03/29/93	RCPT. ASS'Y., SIGNAL MODULE, Z-PACK 2mm FB
2 PLC ± .13	3 PLC ± .13	APVD D. BAECHTLE 03/29/93	4 ROW, 3.55mm PRESS FIT LEAD LENGTH
4 PLC ± -	ANGLES ± -	APPLICATION SPEC	
MATERIAL	FINISH	SIZE CAGE CODE DRAWING NO	RESTRICTED TO
		WEIGHT	A1 00779 C=536511
		CUSTOMER DRAWING	SCALE 4:1 SHEET 1 OF 1 REV Y3