

Distributed by:

JAMECO[®]
ELECTRONICS

www.Jameco.com ♦ 1-800-831-4242

The content and copyrights of the attached
material are the property of its owner.

Jameco Part Number 852211

LOC	DIST	REV	DESCRIPTION	DATE	BY	APPV
AA	20	T	REVISED PER EC 001C-0163-00	21AUG00	DL	AWR

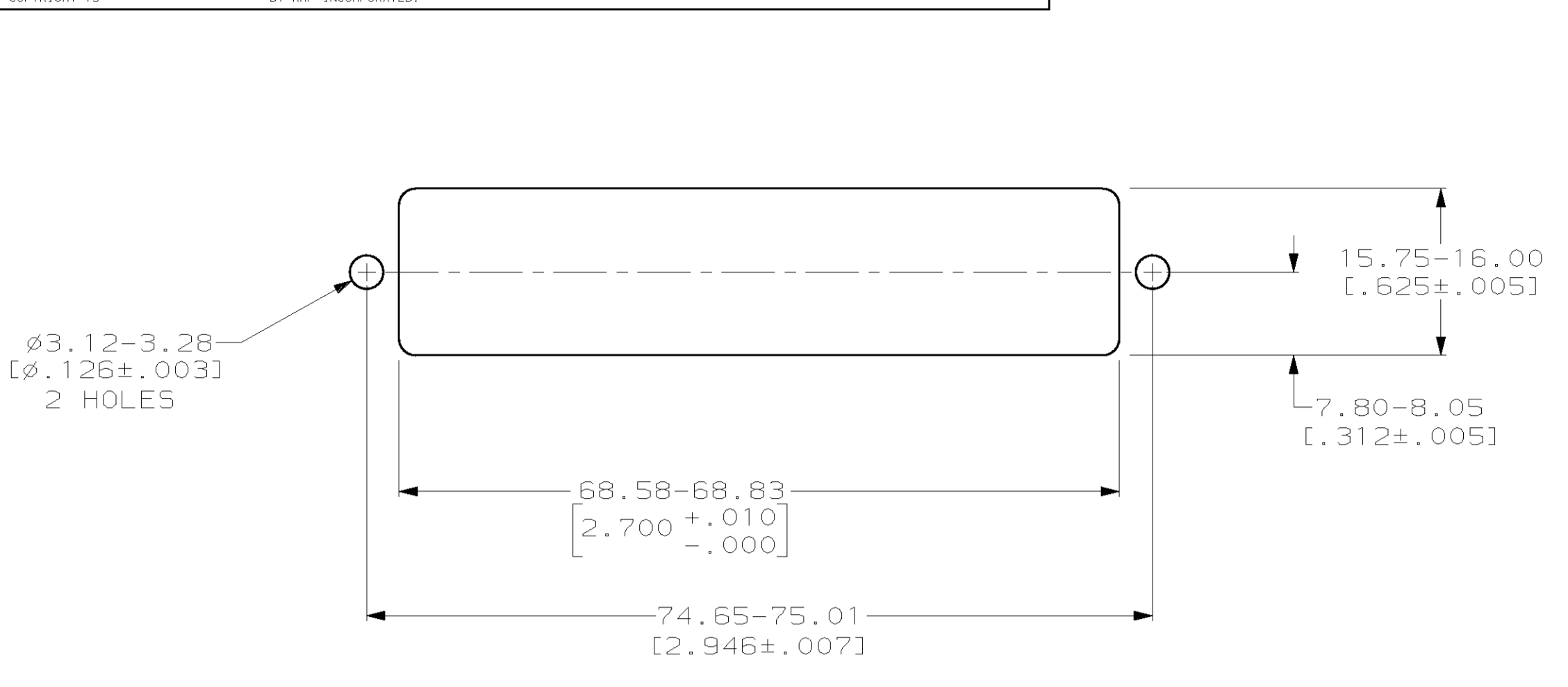

SUGGESTED REAR PANEL MOUNTING CUTOUT DIMENSIONS SCALE 2:1

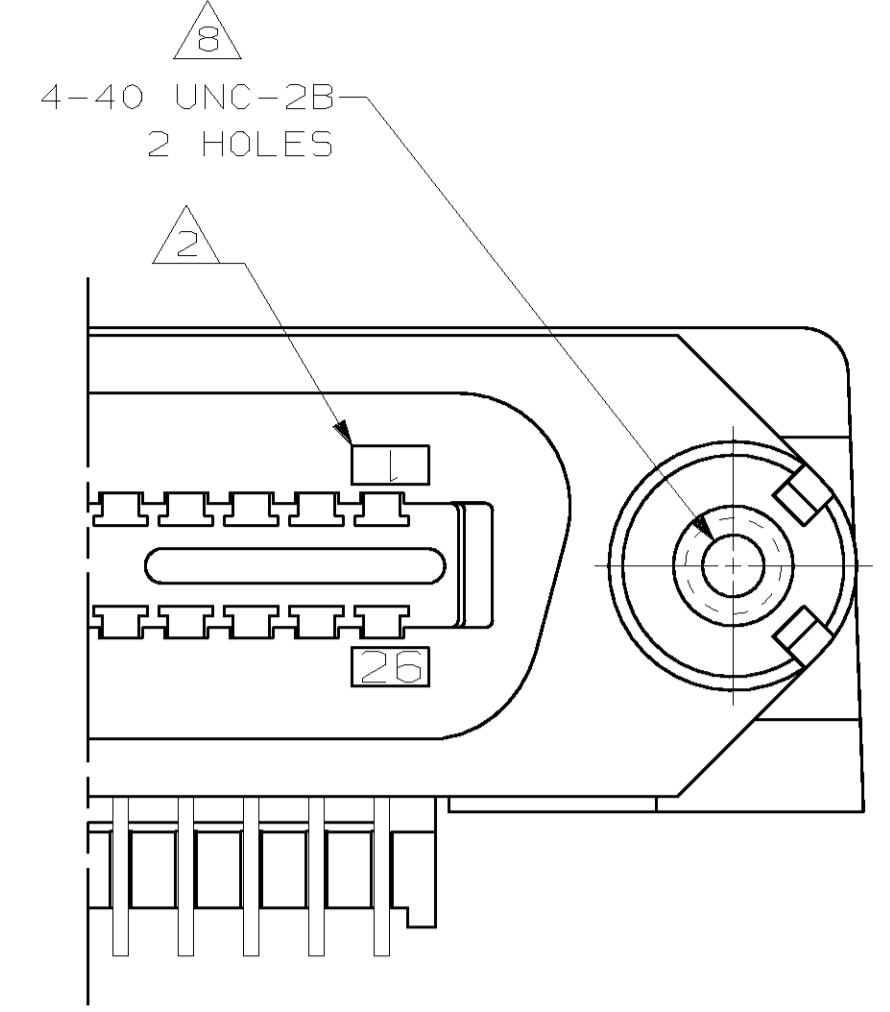

DETAIL A STANDARD ORIENTATION

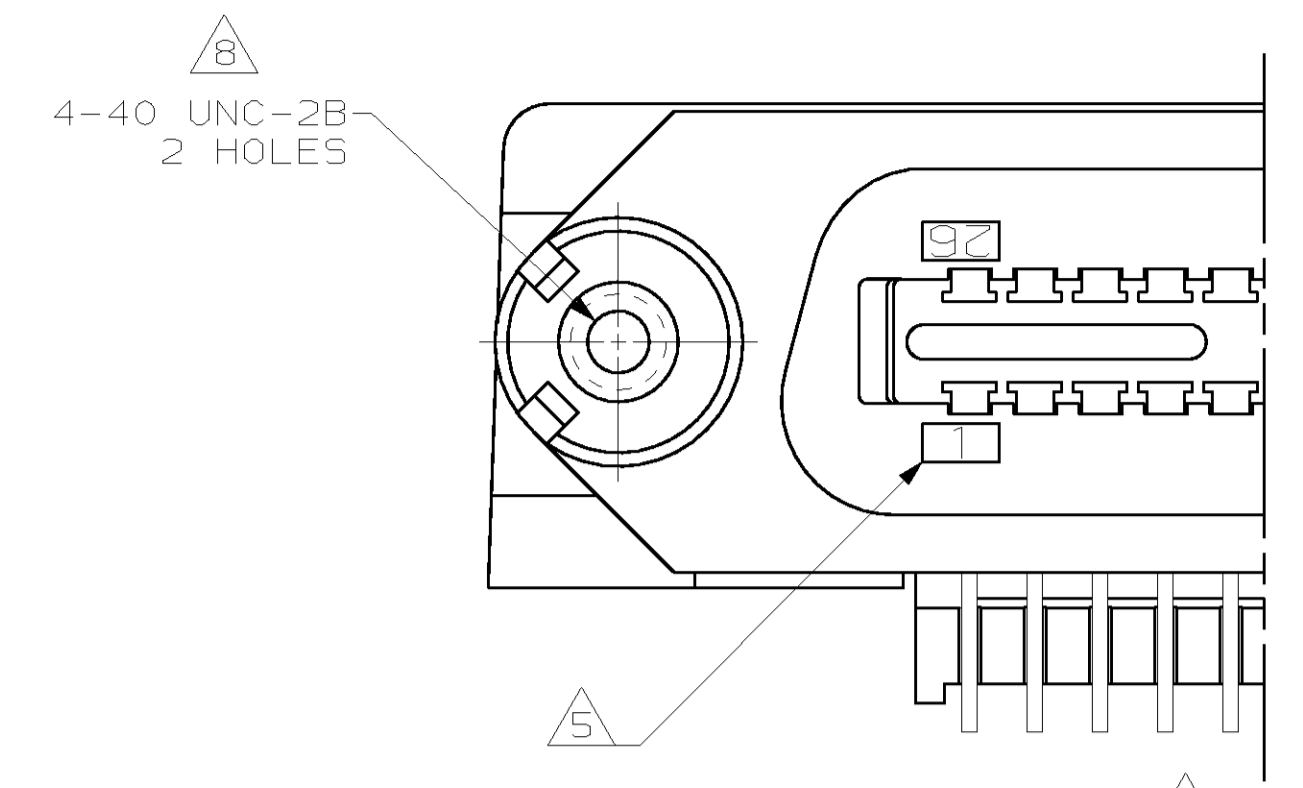

DETAIL B REVERSE ORIENTATION

- 1 MATERIAL: HOUSING, BRACKET, PLATE AND COMB - THERMOPLASTIC, BLACK, 94V-0 RATED. TERMINALS-TAILS - TIN-LEAD OVER NICKEL PLATED HIGH STRENGTH COPPER ALLOY. MATING SURFACE - LOCALIZED GOLD OVER NICKEL PLATED HIGH STRENGTH COPPER ALLOY. THREADED INSERT - #4-40 UNC, BRIGHT ZINC PLATED BRASS.
- 2 TERMINAL 1 IS LOCATED IN THIS ROW FOR STANDARD ORIENTATION, 552725-1, -2 AND -5.
- 3 TERMINAL SUPPORT PLATE CLEARANCE FOR TERMINAL STRAIN RELIEF AND FLUX REMOVAL.
- 4 MAXIMUM PANEL THICKNESS: 1.57 [0.062].
- 5 TERMINAL 1 IS LOCATED IN THIS ROW FOR REVERSE ORIENTATION, 552725-3 AND -6 ONLY.
- 6 DETAILS "A" AND "B" ARE VIEWED FROM MATING SIDE OF RECEPTACLE ASSEMBLY.
- 7 FOR USE WITH A NO.4 BT TYPE SELF-TAPPING SCREW.
- 8 552725-1, -2 AND -3 ARE TAPPED 4-40; -5 AND -6 USE 4-40 THREADED INSERTS.
- 9 INSERT SHALL WITHSTAND 8 INCH-POUNDS OF TORQUE WITHOUT CRACKING HOUSING OR LOOSENING.

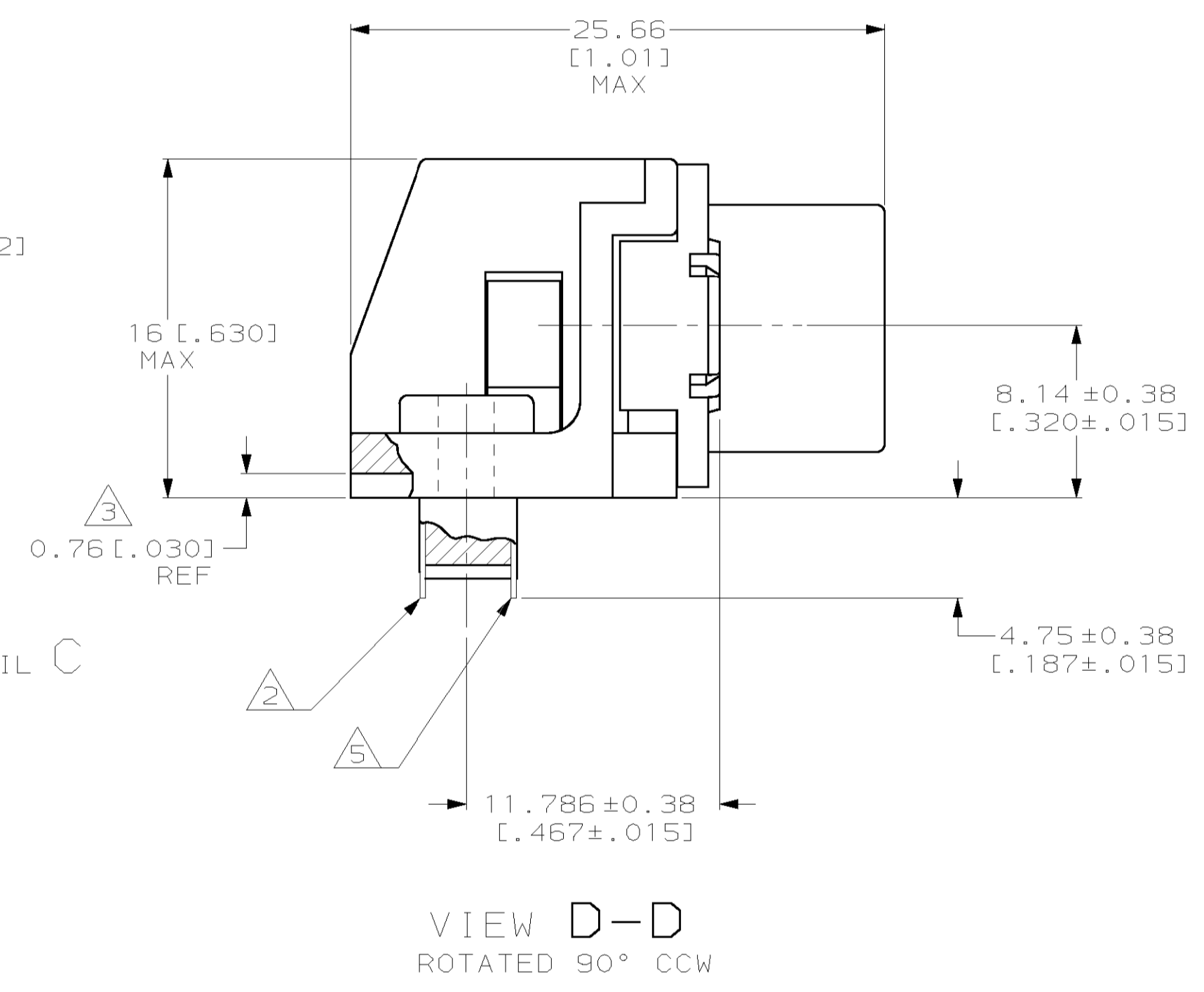
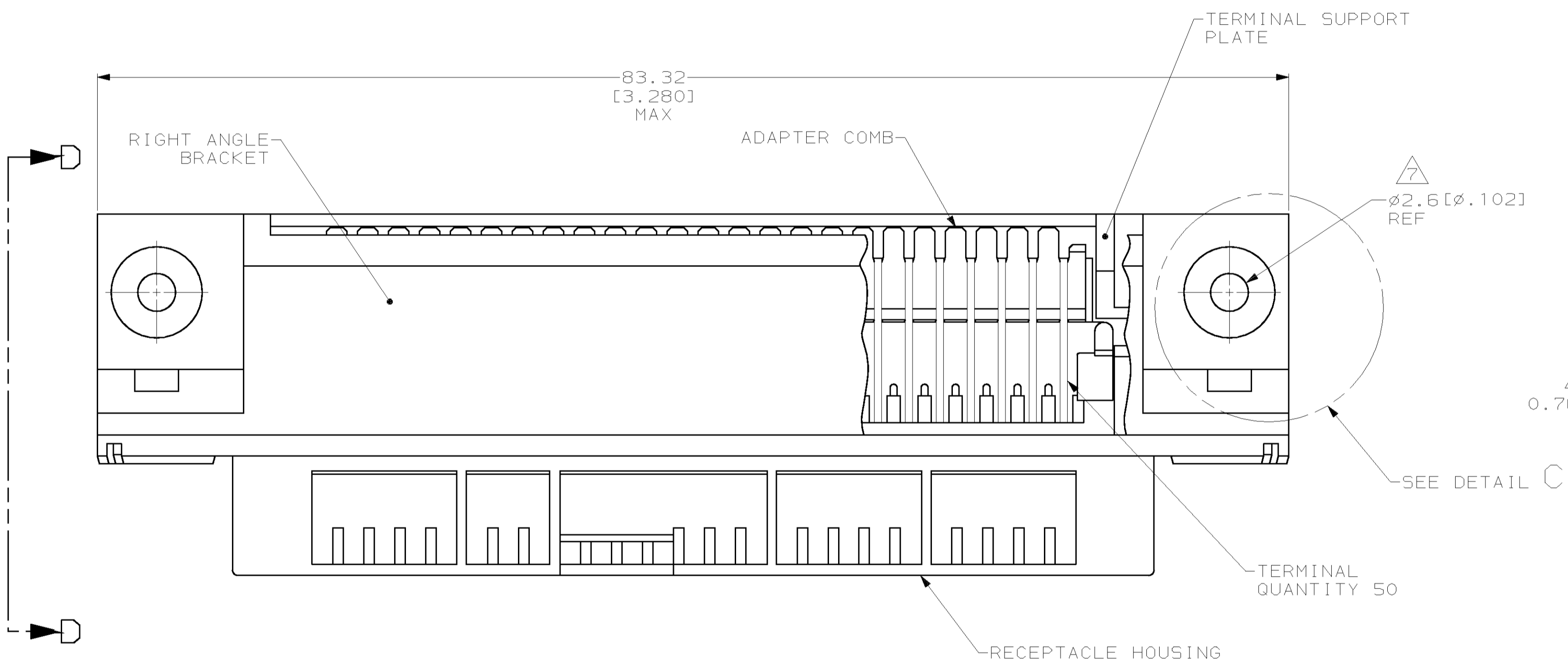

VIEW D-D ROTATED 90° CCW

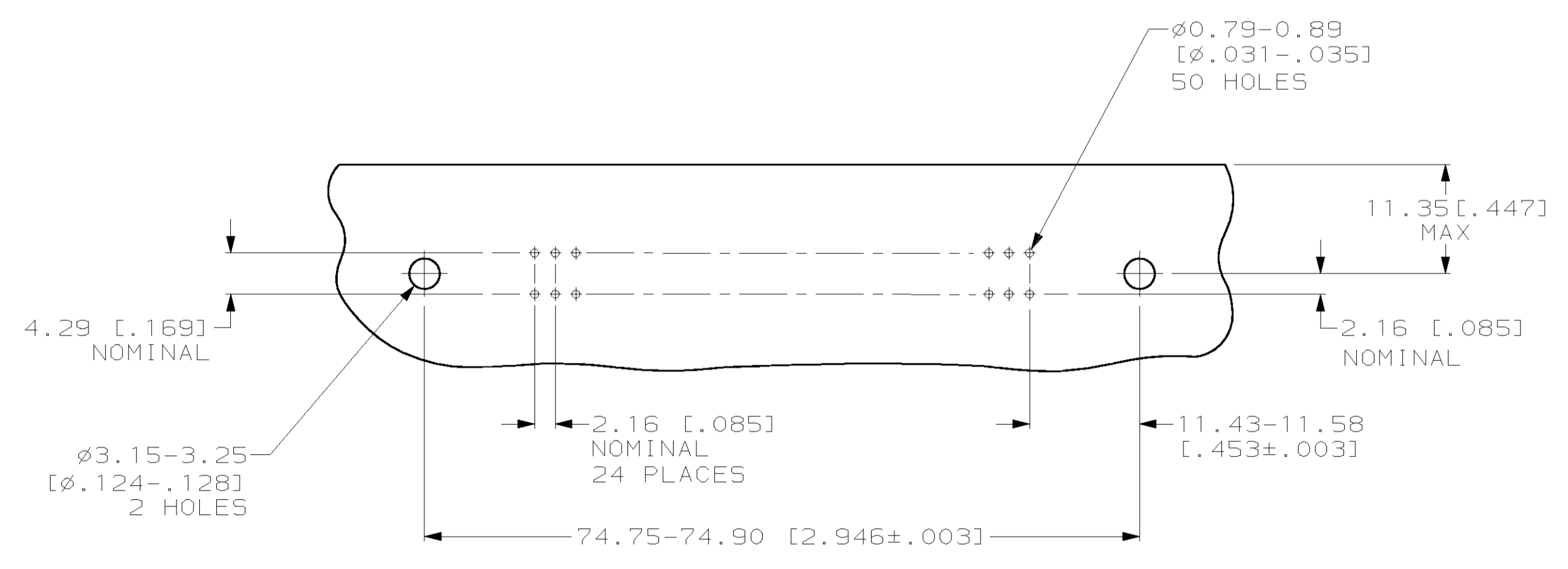

SUGGESTED PRINTED CIRCUIT BOARD MOUNTING DIMENSIONS SCALE 2:1

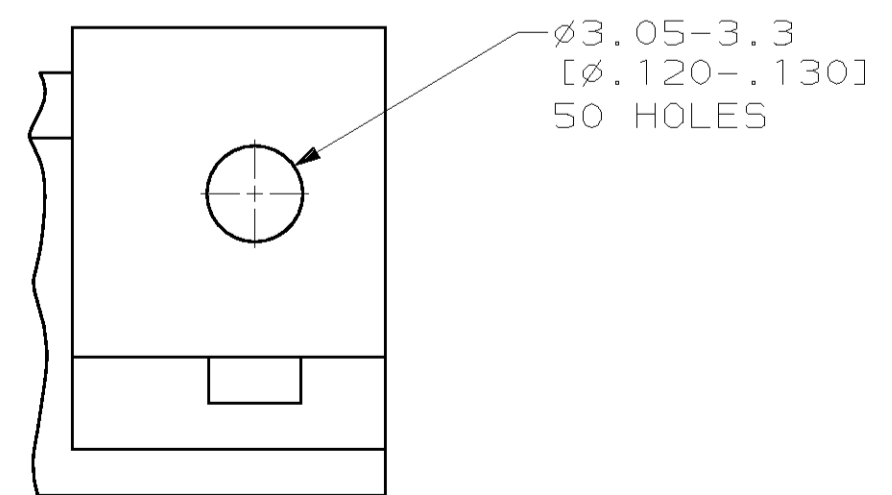

DETAIL C (THRU-BOLT)

THREAD TYPE	TYPE OF MOUNTING	DESCRIPTION	PART NUMBER
THREADED INSERT	SELF-TAPPING	SEE DETAIL B	552725-6
THREADED INSERT	SELF-TAPPING	SEE DETAIL A	552725-5
TAPPED HOLE	SELF-TAPPING	SEE DETAIL B	552725-3
TAPPED HOLE	THRU-BOLT (SEE DETAIL C)	SEE DETAIL A	552725-2
TAPPED HOLE	SELF-TAPPING	SEE DETAIL A	552725-1

DIMENSIONS: mm [INCHES] TOLERANCES UNLESS OTHERWISE SPECIFIED: 0 PLC ±. 1 PLC ±. 2 PLC ±. 3 PLC ±0.13 [0.005] 4 PLC ±. ANGLES ±. FINISH		DWG: DL DRUMMOND 18 AUG 97 CHK: DL DRUMMOND 25 AUG 97 APPV: FLAHERTY 25 AUG 97 PRODUCT SPEC: - APPLICATION SPEC: - WEIGHT: - CUSTOMER DRAWING	AMP Incorporated Harrisburg, PA 17105-3608 NAME: RECEPTACLE ASSEMBLY, 50 POSITION, RIGHT ANGLE, SELF TAPPING, CHAMP® SIZE: A1 CAGE CODE: 00779 DRAWING NO: C-552725 SCALE: 4:1 SHEET: 1 OF 1 REV: T
-----------------------------------------------------------------------------------------------------------------------------------------------------------------	--	-----------------------------------------------------------------------------------------------------------------------------------------------------------------	-----------------------------------------------------------------------------------------------------------------------------------------------------------------------------------------------------------------------------