

Distributed by:

JAMECO[®]
ELECTRONICS

www.Jameco.com ♦ 1-800-831-4242

The content and copyrights of the attached
material are the property of its owner.

Jameco Part Number 849776

THIS DRAWING IS UNPUBLISHED. RELEASED FOR PUBLICATION .19
 (C) COPYRIGHT 19 BY AMP INCORPORATED. ALL RIGHTS RESERVED.

LOC	DIST	REVISIONS			
P	LTR	DESCRIPTION	DATE	DWN	APVD
AA	22	F	REVISED PER EC 0515-0122-03	12JUN03	DLD/ECL

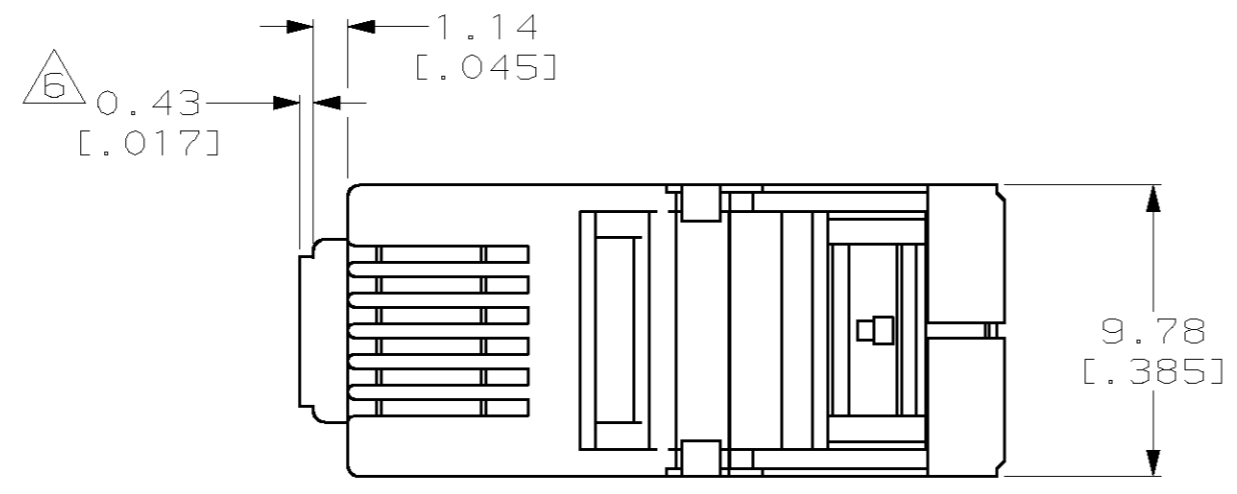

- ① MATERIAL: HOUSING - POLYCARBONATE, CLEAR.
 TERMINAL - 0.36[.014] THICK PHOSPHOR BRONZE PLATED WITH 1.27μm[.000050] THICK GOLD IN LOCALIZED GOLD PLATE AREA, GOLD FLASH OVER THE REMAINDER, OVER 2.54μm[.000100] THICK NICKEL UNDERPLATE.
 SHIELD - 0.25[.010] THICK COPPER ALLOY, SATIN NICKEL PLATED.
- ② ALL DIMENSIONS SHOWN ARE MAXIMUM UNLESS OTHERWISE SPECIFIED.
- 3. PLUG WILL ACCEPT 0.74-0.99[.029-.039] DIAMETER STRANDED WIRE, 26 OR 28 AWG, WITH A .180 DIAMETER MAXIMUM JACKET.
- ④ TERMINATED DIMENSION: 6.15[.242] MAXIMUM.
- ⑤ LATCH SHALL BE IN POSITION SHOWN IN DETAIL "A" AFTER CRIMPING.
- ⑥ CUT-OFF DIMENSION FOR LOOSE PIECE PARTS ONLY.
- ⑦ PACKAGED 1000 PIECES PER BOX.
- ⑧ PACKAGED 100 PIECES PER BOX, 10 BOXES PER CARTON.

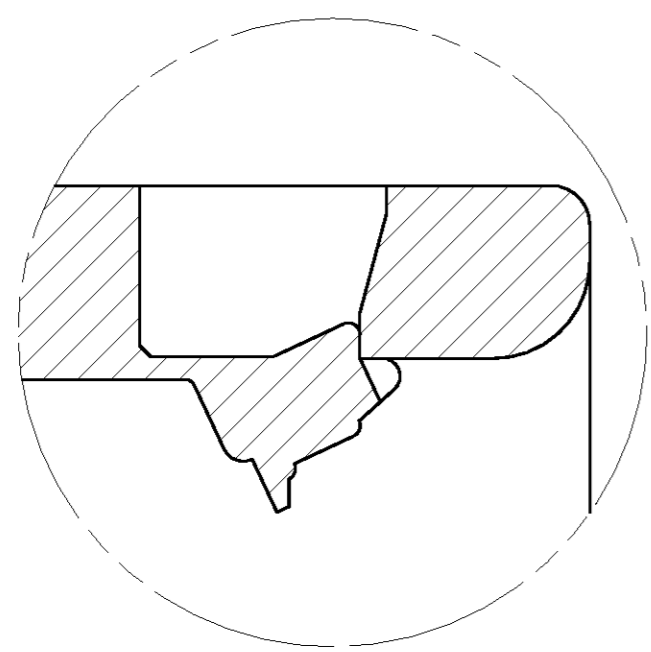
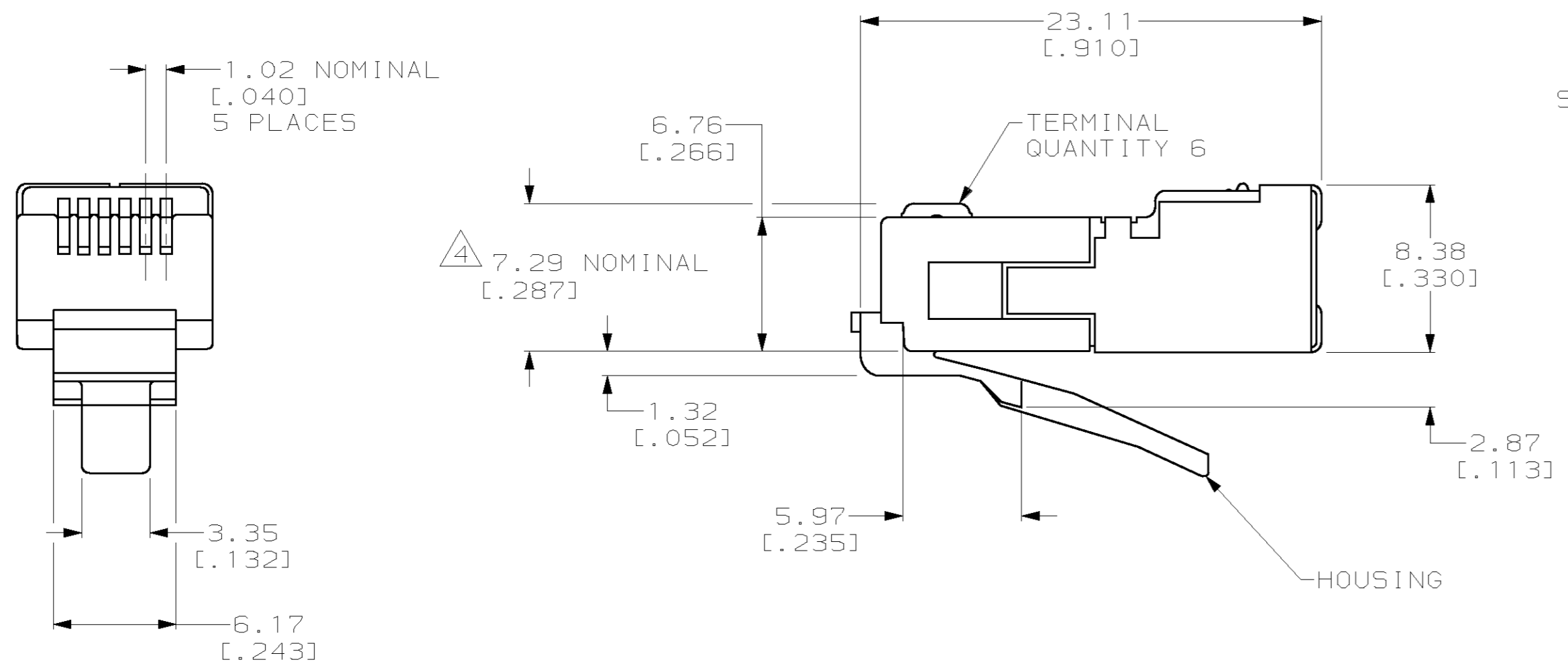

⑤ DETAIL A
 LATCH POSITION AFTER CRIMPING
 SCALE 10:1

LEAD FREE

PACKAGED	DESCRIPTION	PART NUMBER
⑧	LOOSE PIECE	5-555175-3
⑦	LOOSE PIECE	5-555175-2

THIS DRAWING IS A CONTROLLED DOCUMENT.		DWN VIC SLACK 11 MAR 87	TYCO Electronics Harrisburg, PA 17105-3608
DIMENSIONS: mm [INCHES]		CHK BOB FOX 16 MAR 87	
TOLERANCES UNLESS OTHERWISE SPECIFIED: 0 PLC ±- 1 PLC ±- 2 PLC ±0.13[.005] 3 PLC ±- 4 PLC ±- ANGLES ±-		APVD GENE REED 31 MAR 87	
MATERIAL		NAME	
FINISH		PRODUCT SPEC	MODULAR PLUG ASSEMBLY, 6 POSITION, LONG BODY, SHIELDED, ROUND CABLE, STRANDED WIRE
①		APPLICATION SPEC	SIZE CAGE CODE DRAWING NO RESTRICTED TO
①		WEIGHT	A2 00779 C-555175
CUSTOMER DRAWING		SCALE 4:1	SHEET 1 OF 1 REV F

555175