

5745136-3 Product Details

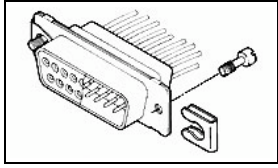

5745136-3

TE Internal Number: 5745136-3



Active

Hardware (AMPLIMITE)

 Always EU RoHS/ELV Compliant (Statement of Compliance)

Product Highlights:

- Accessory Type = Male Screw Retainers
- Thread Size = 4-40
- Screw Length = 5.08 mm
- Clear Chromate Screw Finish
- Packaging Method = Individual

Documentation & Additional Information

Product Drawings:

- [SCREW RETAINER, AMPLIMITE](#) (PDF, English)

Catalog Pages/Data Sheets:

- [AMPLIMITE Subminiature D Connectors - Cable Connectors](#) (PDF, English)

Product Specifications:

- None Available

Application Specifications:

- None Available

Instruction Sheets:

- [Female Screwlock Kits and Male Screw Retainer Kits](#) (PDF, English)

CAD Files: (CAD Format & Compression Information)

- [2D Drawing](#) (DXF, Version 0)
- [3D Model](#) (IGES, Version 0)
- [3D Model](#) (STEP, Version 0)

Additional Information:

- [Product Line Information](#)

Related Products:

- [Tooling](#)

Product Features (Please use the Product Drawing for all design activity)

Product Type Features:

- [Accessory Type](#) = Male Screw Retainers
- [Thread Size](#) = 4-40

Dimensions:

- [Screw Length \(mm \[in\]\)](#) = 5.08 [0.200]

Body Features:

- [Screw Finish](#) = Clear Chromate
- [Screw Plating](#) = Zinc
- [Screw Material](#) = Cold Rolled Steel
- [Retainer Clip Material](#) = Stainless Steel

Industry Standards:

- [Government/Industry Qualification](#) = No
- [RoHS/ELV Compliance](#) = RoHS compliant, ELV compliant
- [Lead Free Solder Processes](#) = Not relevant for lead free process
- [RoHS/ELV Compliance History](#) = Always was RoHS compliant

Conditions for Usage:

- [For Use With](#) = Metal Shell Connectors (HDE and HDP)

Packaging Features:

- [Packaging Method](#) = Individual

Other:

- [Brand](#) = AMP
- [Comment](#) = All parts are packaged unassembled.; Each kit is comprised of two male screws and two retaining clips. Male screw retainers are also furnished as part of cable clamp kits.; Male screw retainers mate with female screwlocks, with HDF metal-shell connectors featuring 4-40 threaded inserts and with HD metal-shell board mount connectors featuring 4-40 threaded inserts or female screwlocks.; Retaining clip must be assembled onto connector flanges with threaded hole toward wire side of connector.

THIS DRAWING IS UNPUBLISHED. RELEASED FOR PUBLICATION
 © COPYRIGHT - By - ALL RIGHTS RESERVED.

LOC	DIST	REVISIONS					
GP	00	P	LTR	DESCRIPTION	DATE	DWN	APVD
		P		REVISED PER ECO-11-004835	11MAR11	RK	HMR

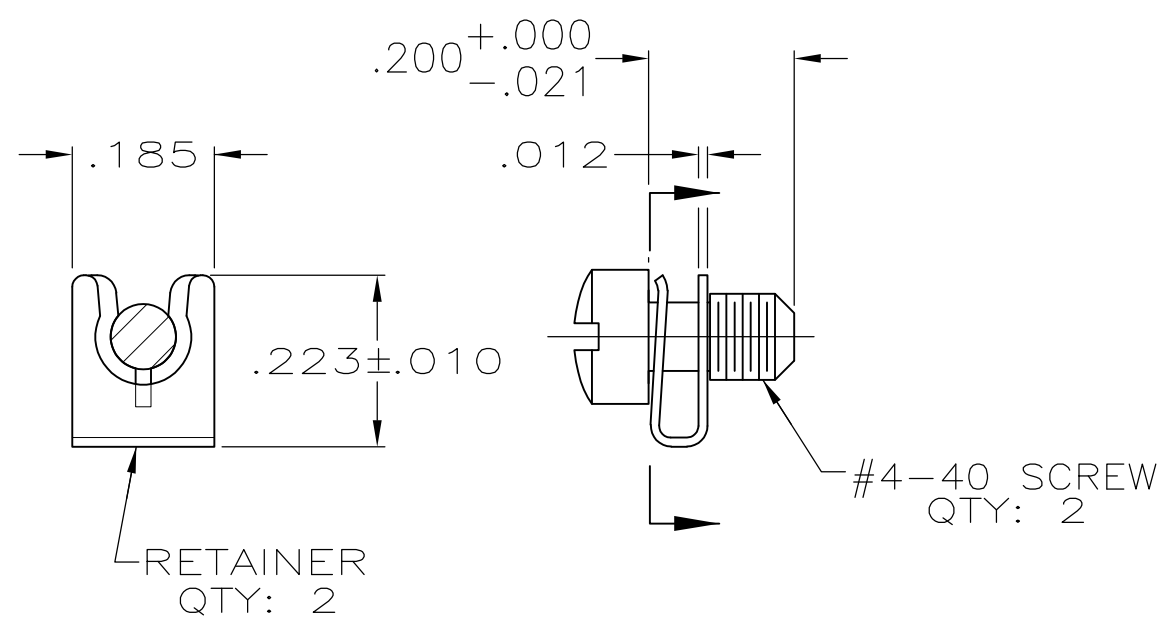

- 1 COLD ROLLED STEEL.
- 2 STAINLESS STEEL.
- 3 ZINC PLATED .000200-.000400 THICK, YELLOW CHROMATE COATING.
- 4 ZINC PLATED .000200-.000400 THICK, CLEAR CHROMATE COATING.
- 5. PARTS PACKAGED UNASSEMBLED.
- 6 PARTS PACKAGED AS A UNIT KIT.
- 7 PARTS INDIVIDUALLY BULK PACKAGED & SHIPPED AS A UNIT PACKAGE.

7	4	5745136-4
6	4	5745136-3
7	3	5745136-2
6	3	5745136-1
PACKAGING	SCREW FINISH	PART NO

THIS DRAWING IS A CONTROLLED DOCUMENT.		DWN S.WAITMAN 29JUN05	TE Connectivity NAME - SCREW RETAINER KIT, AMPLIMITE -				
DIMENSIONS: INCHES		CHK C.ROHDE 29JUN05					
TOLERANCES UNLESS OTHERWISE SPECIFIED:		APVD M.WALMSLEY 29JUN05					
0 PLC ± - 1 PLC ± - 2 PLC ± - 3 PLC ± .005 4 PLC ± - ANGLES ± -		PRODUCT SPEC -					
MATERIAL FINISH		APPLICATION SPEC -	SIZE A3	CAGE CODE 00779	DRAWING NO C-5745136	RESTRICTED TO -	
SCREWS: 1 RETAINERS: 2		WEIGHT -	CUSTOMER DRAWING		SCALE 4:1	SHEET 1 OF 1	REV P