

- △ HOUSING AND TERMINATION COVERS: THERMOPLASTIC, UL94V-0 RATED, COLOR BLACK.
SHELL: STEEL.
PIN CONTACTS: PHOSPHOR BRONZE.
- △ 0.00254 - 0.00762 [.000100 - .000300] TIN-NICKEL OVER 0.00381 - 0.00508 [.000150 - .000200] NICKEL OVER 0.00254 [.000100] MIN COPPER.
- △ 0.00508 - 0.01016 [.000200 - .000400] TIN OVER 0.00127 - 0.00254 [.000050 - .000100] COPPER. LUBRICATED AFTER PLATING.
- △ EITHER 0.76μm [.000030] MIN GOLD PLATE OR 0.08μm [.000003] GOLD FLASH OVER 0.76μm [.000030] MIN PALLADIUM NICKEL PLATE IN LOCALIZED PLATE AREA, 3.00μm [.000118] MIN TIN IN TERMINATION AREA, ALL OVER 1.27μm [.000050] MIN NICKEL.
- 5. RECOMMENDED WIRE: 28 AWG OR 30 AWG, SOLID OR 7 STRAND, WITH A 0.74 - 0.91 [.029 - .036] INSULATION DIAMETER. WIRE MUST BE APPROVED BY TYCO ELECTRONICS.

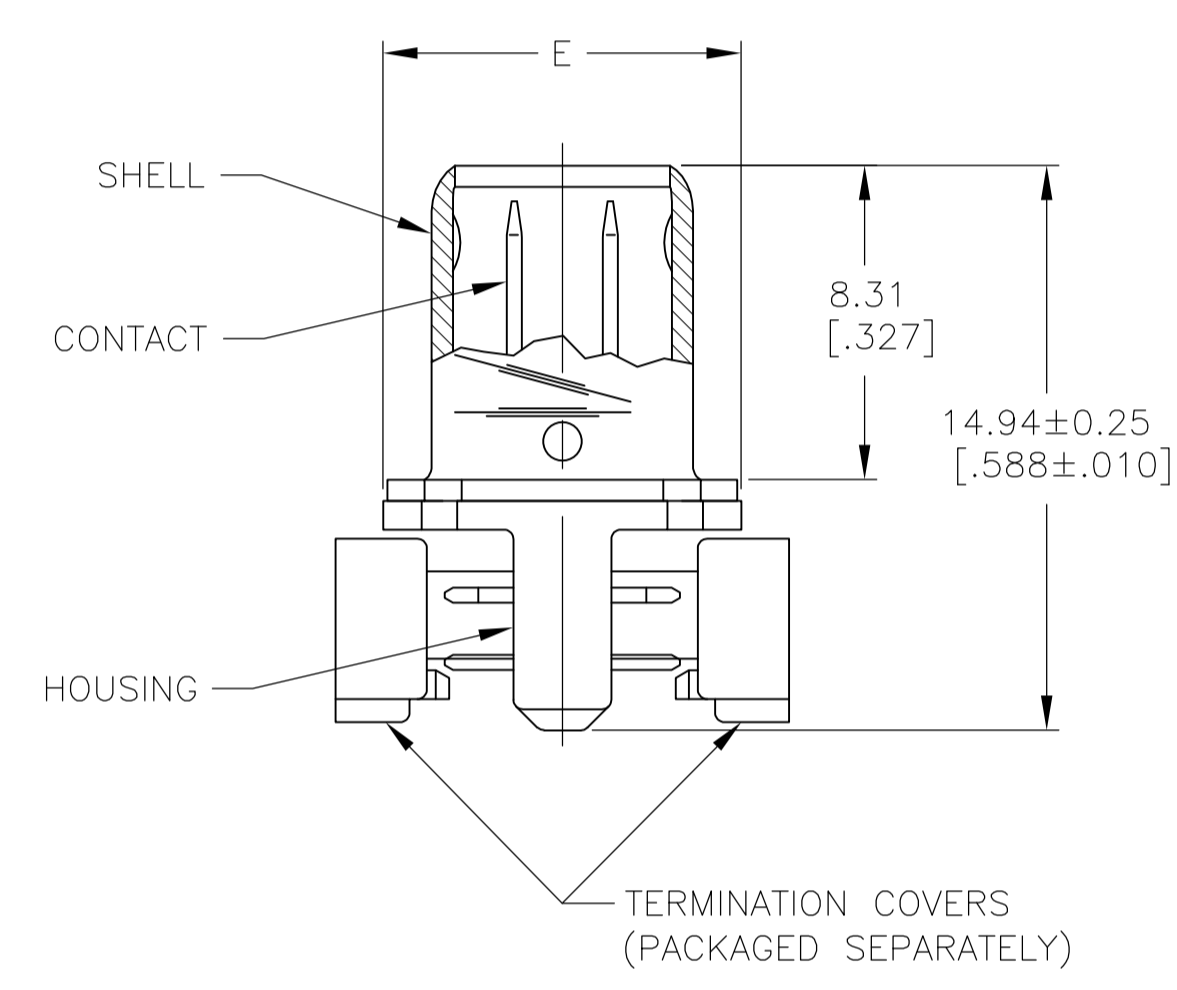

SUPERCEDED BY 5749621-9	9.47 [.373]	71.86 [2.829]	66.60 [2.622]	62.23 [2.450]	49	△4	△2	100	1-5749621-8
SUPERCEDED BY 5749621-5	7.44 [.293]	40.11 [1.579]	34.85 [1.372]	30.48 [1.200]	24	△4	△2	50	1-5749621-7
SUPERCEDED BY 5749621-7	7.44 [.293]	51.54 [2.029]	46.28 [1.822]	41.91 [1.650]	33	△4	△3	68	1-5749621-6
	9.47 [.373]	84.54 [3.329]	79.31 [3.122]	74.93 [2.950]	59	△4	△2	120	1-5749621-0
	9.47 [.373]	71.86 [2.829]	66.60 [2.622]	62.23 [2.450]	49	△4	△2	100	5749621-9
	9.47 [.373]	59.16 [2.329]	53.90 [2.122]	49.53 [1.950]	39	△4	△2	80	5749621-8
	7.44 [.293]	51.54 [2.029]	46.28 [1.822]	41.91 [1.650]	33	△4	△2	68	5749621-7
	7.44 [.293]	40.11 [1.579]	34.85 [1.372]	30.48 [1.200]	24	△4	△2	50	5749621-5
	7.44 [.293]	33.76 [1.329]	28.50 [1.122]	24.13 [.950]	19	△4	△2	40	5749621-4
	7.44 [.293]	26.14 [1.029]	20.88 [.822]	16.51 [.650]	13	△4	△2	28	5749621-3
	7.44 [.293]	24.87 [.979]	19.61 [.772]	15.24 [.600]	12	△4	△2	26	5749621-2
	7.44 [.293]	21.06 [.829]	15.80 [.622]	11.43 [.450]	9	△4	△2	20	5749621-1
E	D	C	B	A	CONTACT FINISH	SHELL FINISH	NO OF POS	PART NUMBER	

**COPYRIGHT 2005
 TYCO ELECTRONICS CORP
 ALL RIGHTS RESERVED**

THIS DRAWING IS A CONTROLLED DOCUMENT.

DIMENSIONS: INCHES	TOLERANCES UNLESS OTHERWISE SPECIFIED:	0 PLC ± -	1 PLC ± -	2 PLC ± 0.13[.005]	3 PLC ± -	4 PLC ± -	ANGLES ± -
MATERIAL	FINISH	SEE TABLE	WEIGHT	—	SIZE	114-40029	RESTRICTED TO
CUSTOMER DRAWING		SCALE	5:1	SHEET	1 OF 1	REV	B

DIN: J. GERACE 17FEB05
 CHK: S. SHUEY 17FEB05
 APD: M. WALMSLEY 17FEB05
 NAME: Tyco Electronics Corporation, Harrisburg, Pa 17105-3608
 PRODUCT SPEC: KIT, PLUG ASSEMBLY, 1.27[.050] SERIES, AMPLIMITE
 APPLICATION SPEC: 108-1228
 DRAWING NO: 5749621
 SCALE: 5:1
 SHEET: 1 OF 1
 REV: B