

© UNPUBLISHED 1974 BY AMP
 INCORPORATED HARRISBURG, PA.
 ALL RIGHTS RESERVED. NO PART OF THIS DRAWING IS TO BE REPRODUCED OR TRANSMITTED IN ANY FORM OR BY ANY MEANS WITHOUT THE WRITTEN PERMISSION OF AMP INCORPORATED.
 FOREIGN PATENTS AND/OR PATENTS PENDING.

REVISIONS			
LTR	DESCRIPTION	DATE	APPROVED
A	REVISED	10-30-74	DC
B	REVISED PER 063A-0256-02	24-JUL-02	W/SF/GP

CONTINUOUS STRIP ON REELS

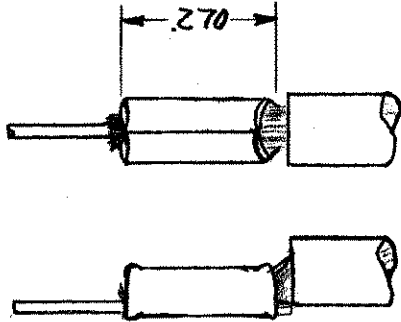
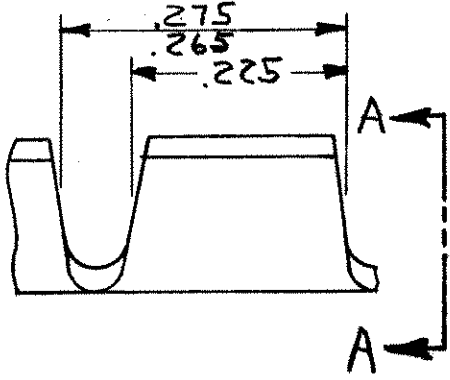
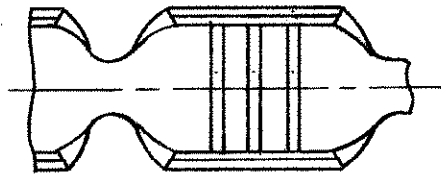

THRU AMP-O-LECTRIC APPLICATION

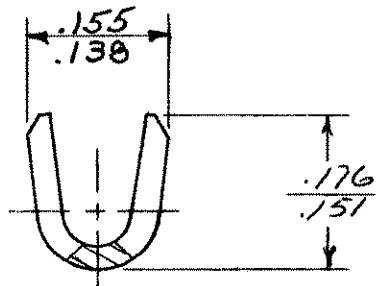

VIEW A-A

1,500 CMA - 5,000 CMA	62318-1
WIRE RANGE	PART NO

UNLESS OTHERWISE SPECIFIED DIMENSIONS ARE IN INCHES. TOLERANCES ON: DECIMALS ±.015 ANGLES ±10°	CONTRACT NO	 AMP INCORPORATED Harrisburg, Pa.		
	DR S. SCHAFFHAUSER 8/20/74			NAME
MATERIAL	CHK C. FERNALD 8/21/74	SPLICE		
.0195 STEEL	APPD			
FINISH	APPD	SIZE	CODE IDENT NO	DRAWING NO
	NICKEL	DSGN APPD	A	00779
	OTHER APPD C.C. [Signature] 8/21/74	SCALE	SHEET 1 of 1	